

ELIO

YABU PUSHELBERG



COLLECTION EXTENSIONS

The 2025 ELIO collection captures the essence of outdoor lounging with the introduction of new sofas, daybeds, and poufs. Expanding on the softly rounded silhouette of the original series, the low profiles and graceful curves evoke the beauty of water-smoothed pebbles. Every element is crafted to prioritize comfort and versatility, blending organic shapes with modern sophistication. Modular back and armrest options invite personalized compositions, ensuring each creation is distinctly your own.

TRIBÙ



1 SEATER



2 SEATER
FULL BACKREST



3 SEATER
FULL BACKREST



DAYBED
FULL BACKREST



1 SEATER POUF



2 SEATER POUF



3 SEATER POUF



DAYBED POUF



2 SEATER
MERIDIENNE RIGHT



3 SEATER
MERIDIENNE RIGHT



DAYBED
MERIDIENNE RIGHT



2 SEATER
MERIDIENNE LEFT



3 SEATER
MERIDIENNE LEFT



DAYBED
MERIDIENNE LEFT



2 SEATER
EXTENSION



DAYBED
EXTENSION

FRAME

T-TEAK



WEAVE

10-LINEN



AMANU

YABU PUSHELBERG



COLLECTION ADDITIONS

Blending the beauty and durability of teak with the sophisticated charm of woven Canax® sling seats, AMANU introduces new lounging additions. Central to the ensemble is the signature three-seater sofa with generously spacious seating. The collection's new daybed offers a refined retreat, featuring a delicate floating effect reminiscent of the collection's dining chairs. Completing the new ensemble is a selection of variously shaped coffee tables, each imbued with the distinctive look of the collection's dining table, fitting any outdoor setting.

TRIBÙ



3 SEATER SOFA



DAYBED



LOW TABLE
ROUND 90
H 28 / 35 / 42 CM



LOW TABLE
ROUND 125
H 28 / 35 / 42 CM



LOW TABLE
RECTANGULAR 155
H 28 / 35 / 42 CM



C-TABLE

FRAME

T-TEAK

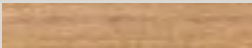

WEAVE

10-LINEN



TABLE TOP

C15-SABBIA



C80-SCIISTO





DUNES

YABU PUSHELBERG

TABLE ADDITIONS

The timeless DUNES table, with its gently domed sculptural base and smooth circular top, welcomes a 2025 addition. The new low table features not one but three of its signature bases in varying sizes, supporting an organically shaped, pebble-inspired top. As unpretentious as the original monobase, this low table complements any outdoor setting. Available in solid teak for warmth, a terrazzo-inspired finish, or with contrasting materials, making a design statement, it allows you to customise outdoor spaces just as you envisioned.

TRIBÙ



SIDE TABLE SMALL
W 81 CM
L 105 CM
H 32 CM



SIDE TABLE LARGE
W 107 CM
L 140 CM
H 32 CM

FRAME

T-TEAK



LUCCA

STUDIO SEGERS



NEW COLLECTION

At first glance, the new LUCCA collection feels instantly familiar, making it easy to love. Then dive deep, and subtle design details emerge. The armchair and lounge chair feature graceful silhouettes inspired by Japanese calligraphy, while the armrests and woven textile bands pay tribute to Southern braiding techniques. The soft fibre's core offers gentle stretch for enhanced comfort while sinking into its cushions. The dining table's shield-shaped supports and rounded ceramic top make it a timeless centrepiece, complementing any outdoor setting.

TRIBÙ



ARMCHAIR



LOUNGE CHAIR



DINING TABLE
240 X 110 CM



DINING TABLE
320 X 115 CM

FRAME

10-LINEN

20-CLAY

89-WENGÉ

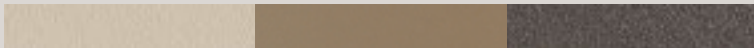

WEAVE

10-LINEN

89-WENGÉ



TABLE TOP

C11-SIENNA

C76-PEBBLE

C86-POMPEI



*see pricelist for more information

TRIBÙ

SENJA

STUDIO SEGERS

ORGANIC CORNER MODULE

SENJA introduces an innovative extension module featuring a 135-degree angle. This addition enhances the sofa's modular versatility, allowing for the creation of organically shaped settings. Effortlessly connect it with the existing sofa, armchair, and lounge components, or position it at the end, creating a cozy enclosure. Alternatively, it can stand alone as an isle of relaxation. This uniquely angled SENJA module continues to push the boundaries of outdoor comfort and style, ensuring every corner to be inviting and chic.

TRIBÙ



POUF MODULE



SINGLE MODULE



DOUBLE MODULE



RIGHT CORNER
ARM HIGH



LEFT CORNER
ARM HIGH



RIGHT CORNER
ARM LOW



LEFT CORNER
ARM LOW



2-SEATER
ARM HIGH



2-SEATER
ARM LOW

FRAME

10-LINEN

89-WENGÉ



LEGS

T-TEAK

10-LINEN

89-WENGÉ

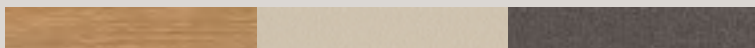

*see pricelist for more information

TRIBÙ

CESTA

MONICA ARMANI

SWIVEL LOUNGE CHAIR

CESTA draws its inspiration from traditional basket weaving methods. From ancient plaiting and coiling to modern industrial weaving designed for elevated outdoor style, enjoyment, and durability, today's artisans interpret time-honoured skills using aluminium and rope. Distinguished by clean lines and minimal adornment, CESTA's woven backrest plays the starring role. The sumptuous cushioning complements the sleek frame, while the seat offers gentle movement from side to side, making it perfect for relaxed groupings and intimate conversations.

TRIBÙ



LOUNGE CHAIR

FRAME

10-LINEN



WEAVE

10-LINEN



TRIBÙ

MR TRICOT

ILIA ECKHARDT

WIRED ADDITIONS

MONSIEUR TRICOT is a collection of knitted and hand crocheted lighting elements that turn outdoor spaces into a magical place. The new 2025 additions will deepen your connection to them even further. All standing models (30-40-60 cm) of Monsieur Lebonnet, Madame Latoque and Madame Cachet come in a new wired version (220V), equipped with a five-meter cable and an easy-to-use on-off switch. Crafted in high-performing materials and modern technology, they are CE certified and suitable for outdoor use.

TRIBÙ



STANDING LAMPS

KNIT

10-LINEN

30-MOSS

60-BRICK

89-WENGÉ



TRIBÙ

SEREN

TRIBÙ STUDIO

LOW TABLES

Introducing SEREN, a coffee table collection that embodies sophistication, functionality, and versatility. The essence of SEREN's design lies in its interchangeable bases and tops, crafted from premium materials including teak, aluminium, travertine, and ceramics. Combined with a variety of height options, these allow for endless design possibilities. Though inherently robust, SEREN retains a sleek and refined aesthetic. Inspired by the serenity of nature, its soft, rounded edges lend a sense of fluidity and grace, creating a balance between form and function.

TRIBÙ



SIDE TABLE 58 X 58
H 39 / 46 CM



COFFEE TABLE 150 X 100
H 32

FRAME

10-LINEN

20-CLAY

T-TEAK

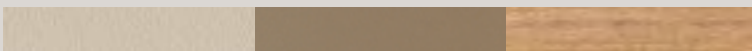

TABLE TOP

C11-SIENNA

C60-MARRONE

C76-PEBBLE

TV-TRAVERTINE

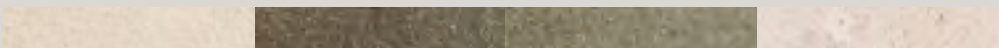

TRIBÙ

MARE

MARC MERCKX

SIDE TABLES

Imagine the soothing rhythm of waves on a light blue ocean. It was the inspiration behind MARE. This side table is a reinterpretation of the classic Martini table. Designed for effortless use on lazy afternoons or cozy nights, it can be easily positioned beside sofas and loungers, with the base sliding underneath. Its textured glass tabletop enhances the lightness of the design, casting gentle ripples across the floor as sunlight dances upon its surface. MARE is a must-have addition to any outdoor setting, where every moment spent feels like a holiday.

TRIBÙ



SIDE TABLE DIA 32
H 40/50 CM



COFFEE TABLE DIA 48
H 40/50 CM

FRAME

10-LINEN

20-CLAY

89-WENGÉ

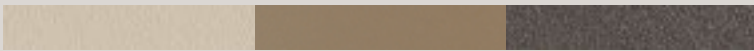
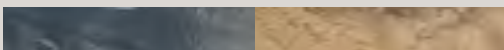

TABLE TOP

G40-DUSK

G88-AMBER



TRIBÙ

TRIBÙ FABRICS

Simple and sophisticated. Vibrant and soothing. Soft and strong at the same time. Like nature itself, Tribù's 2025 fabrics are a blend of the best it has to offer. They merge human craftsmanship and innovation with nature's beauty, effortlessly withstanding its elements. Reflecting tranquil earthy tones, refreshing ocean blues, and serene forest greens, all shades and textures are designed to make life's moments extraordinary. Every thread and weave is a tribute to the great outdoors, where elegance comes naturally.

TRIBÙ

INSPIRATION GUIDE
2024

INDEX

TRIBÙ ATMOSPHERE

Preferred materials	16
Lighting	18

NEW COLLECTION 2024

Suro collection	34
Otto dining tables	36
Mai poufs	38

UPDATES 2023

Illum armchair	42
Natal Alu x coffeetables	44
Pure sofa	46
Tao dining table	48
Dunes side table	50
Vis à Vis bench	52
Natal Alu sofa collection	54

INDEX

LOUNGING

set 1	Vis à Vis sofa <i>landscape</i>	58
set 2	Pure sofa <i>landscape</i>	64
set 3	Suro Banquette	70
set 4	Mood sofa	76
set 5	Nodi sofa	82
set 6	Natal Alu sofa	88
set 7	Senja sofa	94
set 8	Vis à Vis sofa	100
set 9	Pure sofa	106

DINING

set 10	Tao dining table	114
set 11	Otto round dining table	120
set 12	Otto rectangular dining table	126
set 13	Suro dining table <i>landscape</i>	132
set 14	Nox dining table	138
set 15	Amanu dining table	144
set 16	Ukiyo dining table	150
set 17	Suro dining table	156





TRIBÙ ATMOSPHERE

Timeless, pure, and refined – these are the unmistakable traits of Tribù designs. Our luxurious, understated outdoor furniture speaks of elegance, free from extravagant shapes or overpowering colors that might detract from its essence. Immerse yourself in the “Tribù Atmosphere” and find tranquility in a realm of complete comfort and relaxation. A world where we can disconnect from the busyness of life and reconnect with nature and the people who matter most to us.













Flagship store - Los Angeles





Flagship store - Los Angeles





PREFERRED MATERIALS

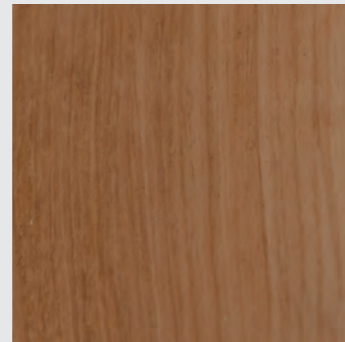
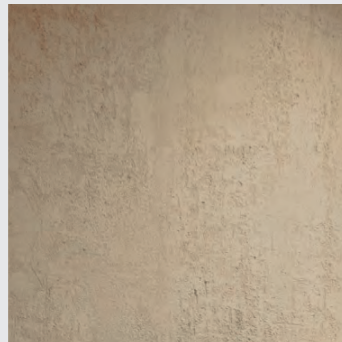
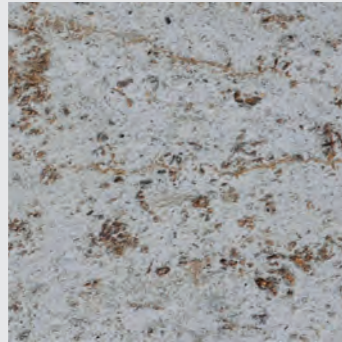

clockwise
muschelkalk - floor
jute - ceiling
teak - dividers
stucco - wall



RECOMMENDED LIGHTING



ARCO MINI TRACK SHORT - PRADO

spot

acrotrack mini short black ano 2700K 40° CRI 90+

track

48V track 01 - black str - 3m

accessoires

48V track dimmable DALI driver 70 or 150W constant voltage





NEW COLLECTION 2024

Driven by an unwavering ambition for research and innovation, we embark on a continuous journey of self-improvement, refining both ourselves and our existing creations. Attentive to the feedback of our valued customers, we actively explore novel opportunities, embracing them wholeheartedly when they emerge. Our brand exhales luxury at its finest, therefore we ought to deliver the best products, manufactured with the highest quality materials and strive towards designs that exhale all of these qualities.



DINING TABLE**

W 210 cm
D 110 cm
H 75,5 cm



BANQUETTE

W 163 cm
D 87 cm
H 75 cm



LOUNGE CHAIR

W 71 cm
D 75 cm
H 74 cm



ARMCHAIR

W 61 cm
D 62 cm
H 83,5 cm



DINING TABLE

W 280 cm
D 110 cm
H 75,5 cm



ENDLESS COMBINATIONS

W 420 cm / 490 cm / 560 cm / ...
D 110 cm
H 75,5 cm

FINISHES FRAME

T-Teak 20-Clay*



FINISHES WEAVE

12-Hemp* 10-Linen*

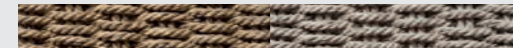

**this size may not be placed single in showroom
*new material / colour (only for seating furniture)

SURO

BY CHRISTOPHE DELCOURT





DINING TABLE**

Ø 148 cm
H 74,7 cm



DINING TABLE 320**

W 320 cm
D 110 cm
H 74,7 cm



DINING TABLE*

Ø 148 cm
H 74,7 cm



DINING TABLE 290*

W 290 cm
D 110 cm
H 74,7 cm

FINISH FRAME

T-Teak



FINISHES TOP

C15-Sabbia**

C80-Scisto**

TV-Travertine*

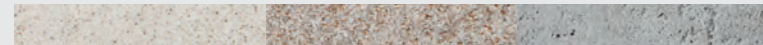

**thickness top 20 mm

*new material (on request for dining tables), thickness top 40mm



OTTO

BY MARC MERCKX



POUF SQUARE

W 100 cm
D 100 cm
H 36 cm



POUF RECTANGULAR

W 100 cm
D 50 cm
H 36 cm

FINISH WEAVE

12-Hemp*



*new material

MAI

BY ILIA ECKARDT





UPDATES 2024

Due to our ambition and drive for research and innovation, we continuously better ourselves and our existing items. We listen to our customers, actively search for new opportunities and act upon them if they present themselves. Our brand exhales luxury at its finest, therefore we ought to deliver the best products, manufactured with the highest quality materials and strive towards designs that exhale all of these qualities.



ARMCHAIR

W 56 cm
D 50 cm
H 76 cm

FINISHES FRAME

00-White

10-Linen

20-Clay*

89-Wenge



*new colour

ILLUM

BY MERCKX & MAES





COFFEE TABLE HIGH

Ø 35 cm
H 55 cm



COFFEE TABLE LOW

W 44 cm
D 40 cm
H 35 cm



COFFEE TABLE LOW

W 60 cm
D 60 cm
H 35 cm

FINISHES FRAME

00-White

10-Linen

20-Clay*

89-Wengé

*new colour



NATALALU X

BY STUDIO SEGERS



LOUNGER (without wheels)

W 209 cm
D 90 cm
H 25 cm



CABANA DAYBED

W 189 cm
D 219 cm
H 205 cm



EXTENSION DOUBLE*

W 190 cm
D 98 cm
H 63 cm



CASUAL CUSHION SET + CORNER**



LOUNGER (with wheels)

W 209 cm
D 90 cm
H 25 cm



LOUNGER (without wheels & legs)

W 209 cm
D 90 cm
H 17,5 cm

FINISH FRAME

T-Teak



FINISH SCREEN AND CURTAINS CABANA

V54-Oyster

V64-Nature grey

V70-Stone

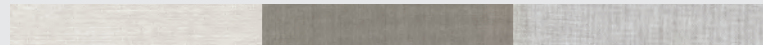

New corner casual back cushion set available**

All double seat elements are now provided with one large seat cushion*

PURE SOFA

BY ANDREI MUNTEANU





DINING TABLE

W 240 cm
D 120 cm
H 74.4 cm

FINISHES

10-Linen

89-Wengé

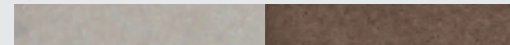

TAO

BY MONICA ARMANI



SIDE TABLE

Ø 48 cm
H 50 cm



COFFEE TABLE

Ø 60 cm
H 40 cm

FINISHES

TZ-Terrazzo*

T-Teak



*new material



DUNES

BY YABU PUSHELBERG



VIS A VIS LOW TABLE

W 159 cm
D 44 cm
H 18 cm

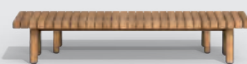

VIS A VIS BENCH

W 159 cm
D 44 cm
H 44 cm

FINISHES FRAME

T-Teak



VIS À VIS

BY PIERGIOGIO CAZZANIGA





SOFA REGULAR

SOFA DEEP

SOFA MERIDIENNE

FINISHES FRAME

10-Linen*

89-Wengé

*new colour

NATAL ALU

BY STUDIO SEGERS





LOUNGING

Outdoor lounging, that's enjoying nature at its finest. Bring inside comfort to your outdoor spaces and enjoy comfortable lounging opportunities with effortless and ingenious designs. We want to inspire and express luxury through elegant details, subtle colours and textures that are in harmony with their setting and environment. Our lounging settings allow you to express yourself and adapt to your way of living, whether it is to relax or entertain.



LOUNGING



SET 1 - VIS À VIS SOFA LANDSCAPE

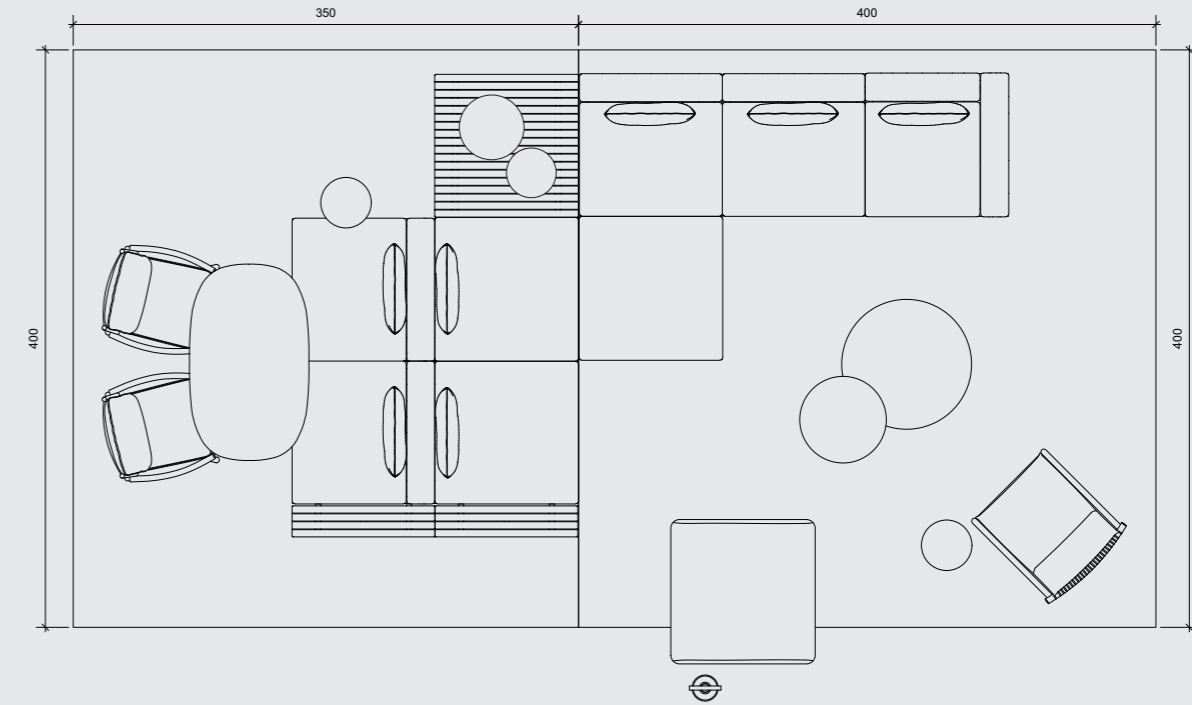

ART. NR.	QTY	DESCRIPTION	FINISH
01728	2	Vis à Vis sofa - extension module double	Teak
01708	1	Vis à Vis sofa - center module	Teak
01792	1	Vis à Vis sofa - pouf module	Teak
01701L	1	Vis à Vis sofa - corner module left arm	Teak
01781	1	Vis à Vis - coffee table 99x99 cm	Teak
01796B	2	Vis à Vis - optional border 22x99 cm	Teak
02612-10	1	Amanu - lounge chair	Teak / Linen
07512	2	Ukiyo - lounge chair	Teak
D2184-89-L30	1	T-Table - low dining	Wengé / Lava stone Moss
05582-12	1	Mai - pouf square 100x100 cm	Hemp
04284-TV	1	Otto - coffee table dia 90 cm	Teak / Travertin
D8302	1	Dunes - coffee table dia 60 cm	Teak
06176-89	2	Natal Alu x - coffee table dia 35 cm	Wengé
D2003-10-350x400	1	Shindi - outdoor rug 350x400 cm	Linen
D2003-10-400x400	1	Shindi - outdoor rug 400x400 cm	Linen

SET 1 - VIS À VIS SOFA LANDSCAPE

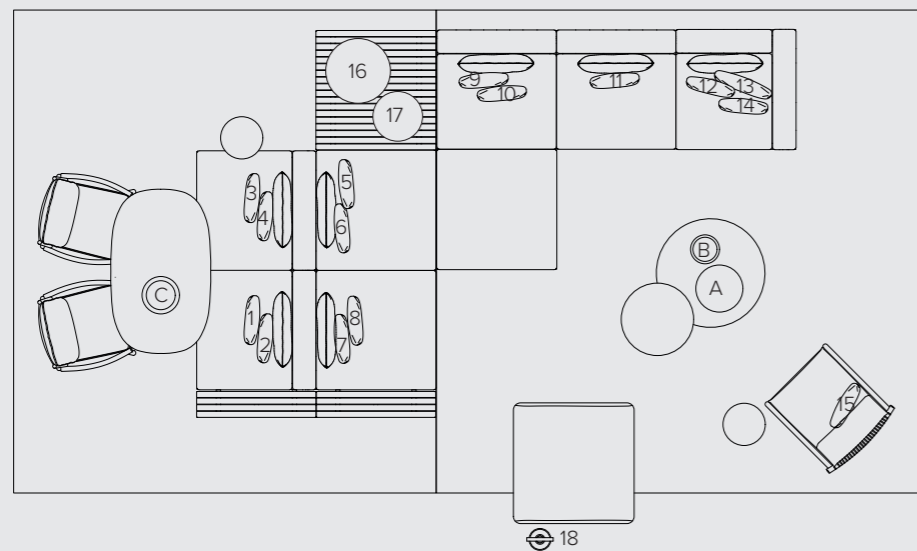

ITEM	ART. NR.	QTY	DESCRIPTION	FINISH
base	C01728-B175W	2	Vis à Vis sofa - extrn module double CU	Taman White Sand
	C01708-B175W	1	Vis à Vis sofa - center module CU	Taman White Sand
	C01792B175W	1	Vis à Vis sofa - pouf module CU	Taman White Sand
	C01701L-B175W	1	Vis à Vis sofa - corner module left arm CU	Taman White Sand
	C02612-F21W	1	Amanu - lounge chair CU	Naram Warm Cotton
	C07512B-E43W + C07512S-E43W	2	Ukiyo - lounge chair CU	Knit Rosemary
deco 1	C01713BP-B155-B41W	1	Deco cushion 42,5x31,5 cm	Natural Cloudy Sky piping Dalsace Canvas
deco 2	C0001-E43W	1	Deco cushion 40x40 cm	Knit Rosemary
deco 3	C0001P-B194-B12W	1	Deco cushion 40x40 cm	Natural Dark Brown piping Linen
deco 4	C0001-F21W	1	Deco cushion 40x40 cm	Naram Warm Cotton
deco 5	C01713B-F21W	1	Deco cushion 42,5x31,5 cm	Naram Warm Cotton
deco 6	C0001P-B155-B41W	1	Deco cushion 40x40 cm	Natural Cloudy Sky piping Dalsace Canvas
deco 7	C0001-F21W	1	Deco cushion 40x40 cm	Naram Warm Cotton
deco 8	C0001P-B194-B12W	1	Deco cushion 40x40 cm	Natural Dark Brown piping Linen
deco 9	C0001-F21W	1	Deco cushion 40x40 cm	Naram Warm Cotton
deco 10	C01713B-E43W	1	Deco cushion 42,5x31,5 cm	Knit Rosemary
deco 11	C01713BP-B155-B41W	1	Deco cushion 42,5x31,5 cm	Natural Cloudy Sky piping Dalsace Canvas
deco 12	C01713B-F21W	1	Deco cushion 42,5x31,5 cm	Naram Warm Cotton
deco 13	C0002-E43W	1	Deco cushion 50x50 cm	Knit Rosemary
deco 14	C0002P-B194-B12W	1	Deco cushion 50x50 cm	Natural Dark Brown piping Linen
deco 15	C0002P-B155-B41W	1	Deco cushion 50x50 cm	Natural Cloudy Sky piping Dalsace Canvas
deco 16	D080140S-30W	1	Monsieur Lebonnet standing 40 cm	Moss
deco 17	D080130S-30W	1	Monsieur Lebonnet standing 30 cm	Moss
deco 18	D09010-89	1	Luna Lantern	Wengé

CUSHIONS / STYLING



B175 Taman White Sand

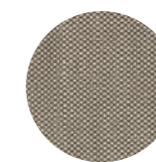

B155 Natural Cloudy Sky

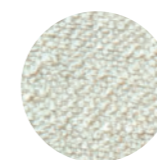

F21 Naram Warm Cotton

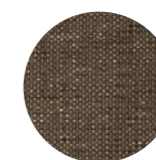

B194 Natural Dark Brown

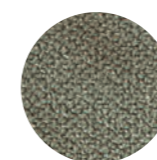

E43 Knit Rosemary



B41 Dalsace Canvas

ITEM DESCRIPTION

- A Segment 39 - special marble, Michaël Verheyden
- B Busk vase M - special marble, Michaël Verheyden
- C Bowl - Classic travertine, When Objects Work



© Michaël Verheyden



© Michaël Verheyden



© When Objects Work



LOUNGING



SET 2 - PURE SOFA LANDSCAPE

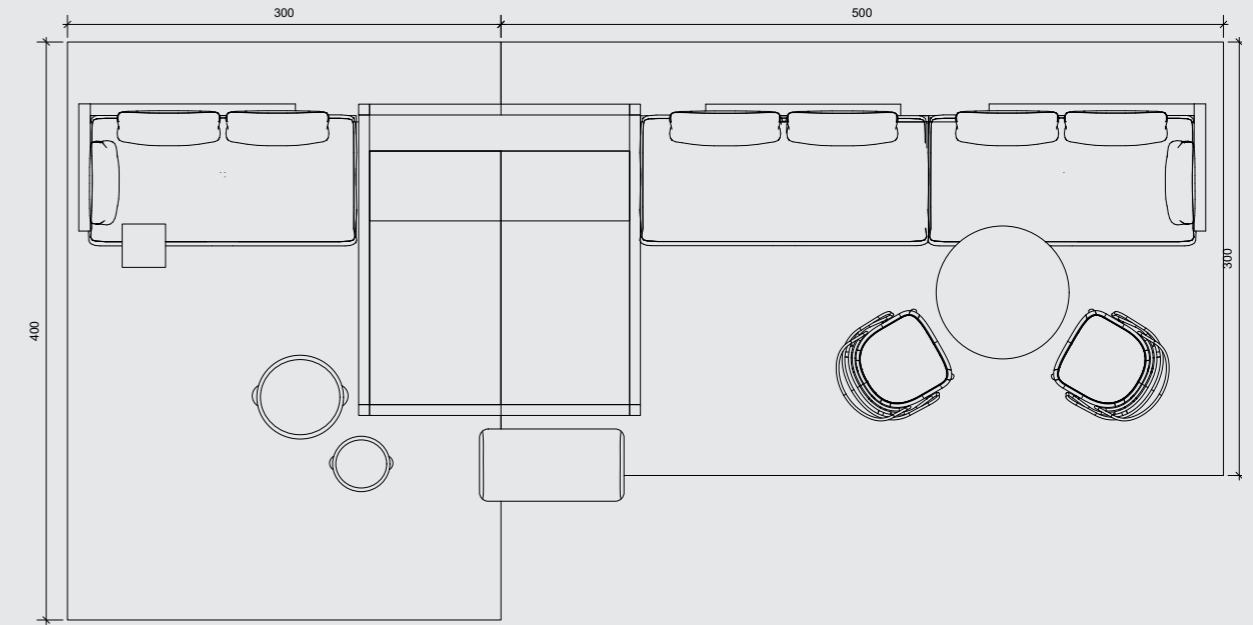

ART. NR.	QTY	DESCRIPTION	FINISH
01204	1	Pure sofa - right arm	Teak
01249	1	Pure cabana - daybed	Teak
01228	1	Pure sofa - extension	Teak
01203	1	Pure sofa - left arm	Teak
02712-T-12	2	Suro - lounge chair	Teak / Hemp
D2161-10-C15	1	T-table - low dining dia 90 cm	Linen / Ceramic Sabbia
01285	1	Pure C-table - side table	Teak
05584-12	1	Mai - pouf rectangular 50x100 cm	Hemp
D2003-12-300x400	1	Shindi - outdoor rug 300x400 cm	Hemp
D2003-12-300x500	1	Shindi - outdoor rug 300x500 cm	Hemp

SET 2 - PURE SOFA LANDSCAPE

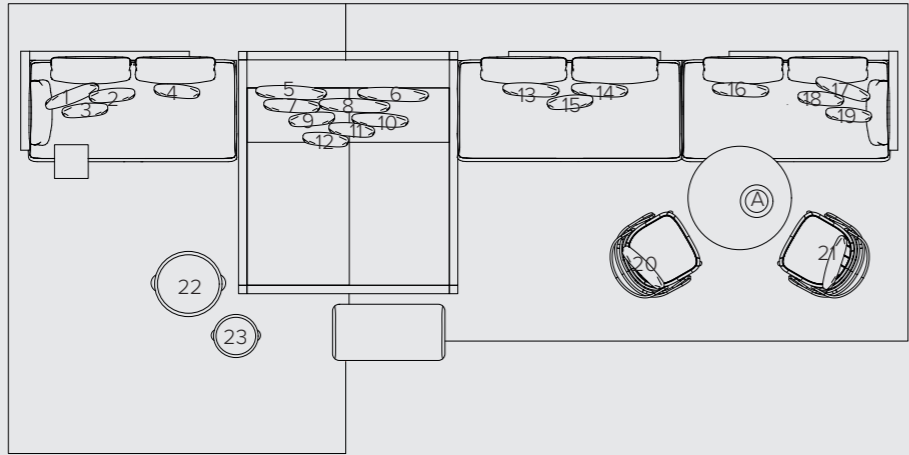

ITEM	ART. NR.	QTY	DESCRIPTION	FINISH
base	C01205CA-F21W	1	Pure sofa - right arm CU	Naram Warm Cotton
	C01249SET-F21W	1	Pure cabana - daybed CU	Naram Warm Cotton
	C01228CA-F21W	1	Pure sofa - extension CU	Naram Warm Cotton
	C01205CA-F21W	1	Pure sofa - left arm CU	Naram Warm Cotton
	C02712S-E45W	2	Suro - lounge chair CU	Knit Mellow Ochre
deco 1	C0002-E46W	1	Deco cushion 50x50 cm	Knit Colorado
deco 2	C0001P-B175-B111W	1	Deco cushion 40x40 cm	Taman Linen piping Canvas Tweed Brown
deco 3	C0001P-E45-B41W	1	Deco cushion 40x40 cm	Knit Mellow Ochre piping Dalsace Canvas
deco 4	C01713BP-F21-B111W	1	Deco cushion 42,5x31,5 cm	Naram Warm Cotton piping Canvas Tweed Brown
deco 5	C0003-E45W	1	Deco cushion 60x60 cm	Knit Mellow Ochre
deco 6	C0003-E46W	1	Deco cushion 60x60 cm	Knit Colorado
deco 7	C0002P-F21-B111W	1	Deco cushion 50x50 cm	Naram Warm Cotton piping Canvas Tweed Brown
deco 8	C0003P-B175-B111W	1	Deco cushion 60x60 cm	Taman Linen piping Canvas Tweed Brown
deco 9	C0001-E46W	1	Deco cushion 40x40 cm	Knit Colorado
deco 10	C0002-E30W	1	Deco cushion 50x50 cm	Gaelic Ochre
deco 11	C0001P-B175-B111W	1	Deco cushion 40x40 cm	Taman Linen piping Canvas Tweed Brown
deco 12	C01713B-F21W	1	Deco cushion 42,5x31,5 cm	Naram Warm Cotton
deco 13	C0002P-B175-B111W	1	Deco cushion 50x50 cm	Taman Linen piping Canvas Tweed Brown
deco 14	C0002P-47-B12W	1	Deco cushion 50x50 cm	Natté Ochre piping Linen
deco 15	C0001-E45W	1	Deco cushion 40x40 cm	Knit Mellow Ochre
deco 16	C0001-E45W	1	Deco cushion 40x40 cm	Knit Mellow Ochre
deco 17	C0002P-B175-B111W	1	Deco cushion 50x50 cm	Taman Linen piping Canvas Tweed Brown
deco 18	C0001-E46W	1	Deco cushion 40x40 cm	Knit Colorado
deco 19	C01713BP-47-B12W	1	Deco cushion 42,5x31,5 cm	Natté Ochre piping Linen
deco 20	C0002P-B175-B111W	1	Deco cushion 50x50 cm	Taman Linen piping Canvas Tweed Brown
deco 21	C0002P-B175-B111W	1	Deco cushion 50x50 cm	Taman Linen piping Canvas Tweed Brown
deco 22	D3010-10	1	Gobi - basket L	Linen
deco 23	D3020-10	1	Gobi - basket S	Linen

CUSHIONS / STYLING

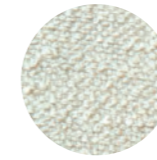

F21 Naram Warm Cotton

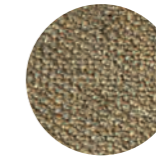

E46 Knit Colorado

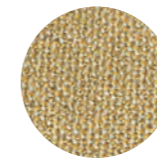

E45 Knit Mellow Ochre

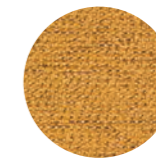

E30 Gaelic Ochre



B174 Taman Linen

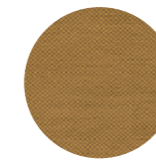

47 Natté Ochre

ITEM DESCRIPTION

A Bowl M lightbrown Dune - marble, Kelly Wearstler for Serax



© Serax



LOUNGING



SET 3 - SURO BANQUETTE

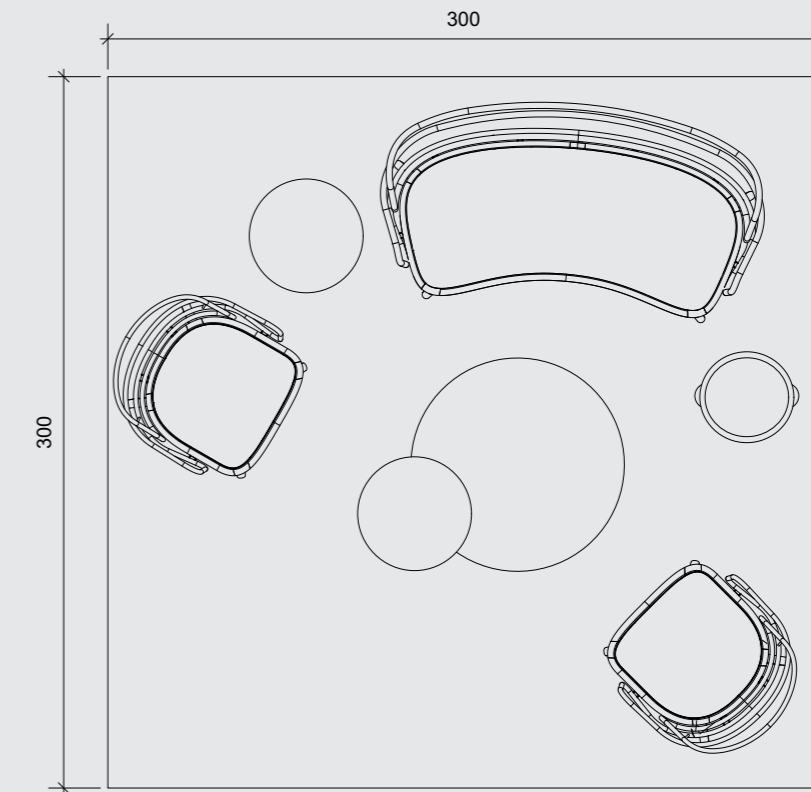

ART.NR.	QTY	DESCRIPTION	FINISH
02708-20-10	1	Suro - banquette	Clay / Linen
02712-T-10	2	Suro - lounge chair	Teak / Linen
04284-TV	1	Otto - coffee table dia 90 cm low	Teak / Travertin
04280-T	1	Otto - coffee table dia 48 cm high	Teak / Teak
04283-TV	1	Otto - coffee table dia 60 cm low	Teak / Travertin
D2003-10-300x300	1	Shindi - outdoor rug 300x300 cm	Linen

SET 3 - SURO BANQUETTE

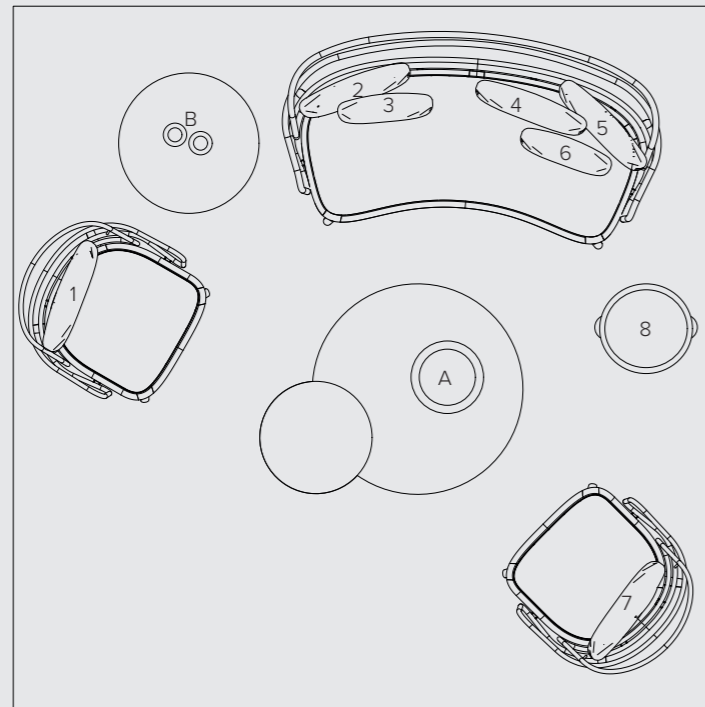

ITEM	ART.NR.	QTY	DESCRIPTION	FINISH
base	C02708S-E32W	1	Suro - banquette CU	Knit Morning Dew
	C02712S-E22W	2	Suro - lounge chair CU	Gaelic Pearl
deco 1	C0002P-E32-B118W	1	Deco cushion 50x50 cm	Knit Morning Dew piping Canvas Lace
deco 2	C0002P-E22-B118W	1	Deco cushion 50x50 cm	Gaelic Pearl piping Canvas Lace
deco 3	C0001-E32W	1	Deco cushion 40x40 cm	Knit Morning Dew
deco 4	C0002-B154W	1	Deco cushion 50x50 cm	Natural Seashell
deco 5	C0002P-E32-B118W	1	Deco cushion 50x50 cm	Knit Morning Dew piping Canvas Lace
deco 6	C0001P-E22-B118W	1	Deco cushion 40x40 cm	Gaelic Pearl piping Canvas Lace
deco 7	C0002-B154W	1	Deco cushion 50x50 cm	Natural Seashell
deco 8	D3020-10	1	Gobi - basket S	Linen

CUSHIONS / STYLING

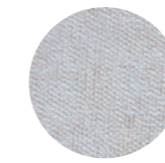

E22 Gaelic Pearl

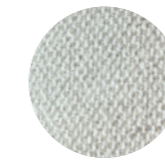

E32 Knit Morning Dew

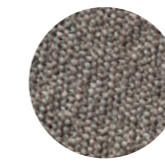

E27 Gaelic Mushroom

ITEM	DESCRIPTION
A	Bowl - Classic travertine, When Objects Work
B	Petite vase - Alabaster, Michaël Verheyden



© Michaël Verheyden



© When Objects Work



LOUNGING



SET 4 - MOOD SOFA

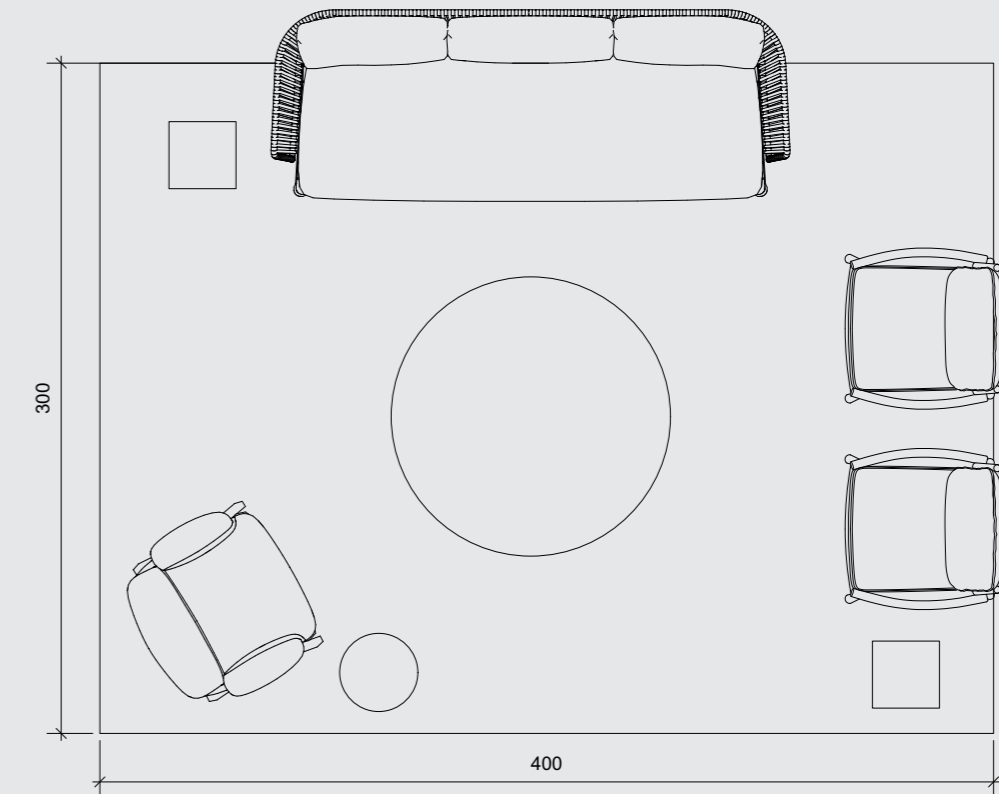

ART. NR.	QTY	DESCRIPTION	FINISH
06209-10	1	Mood - 3-seater	Teak / Linen
05012	1	Nomad - lounge chair	Teak
07512	2	Ukiyo - lounge chair	Teak
D2165-10-C80	1	T-table - coffee table dia 125cm	Linen / Ceramic Sabbia
D8102	1	Roots - side table	Teak
06176-10	1	Natal Alu x - side table dia 35cm	Linen
D8103-L60	1	Tairu - side table	Teak / Lava stone Burgundy
D2003-10-300x400	1	Shindi - outdoor rug 300x400 cm	Linen

SET 4 - MOOD SOFA

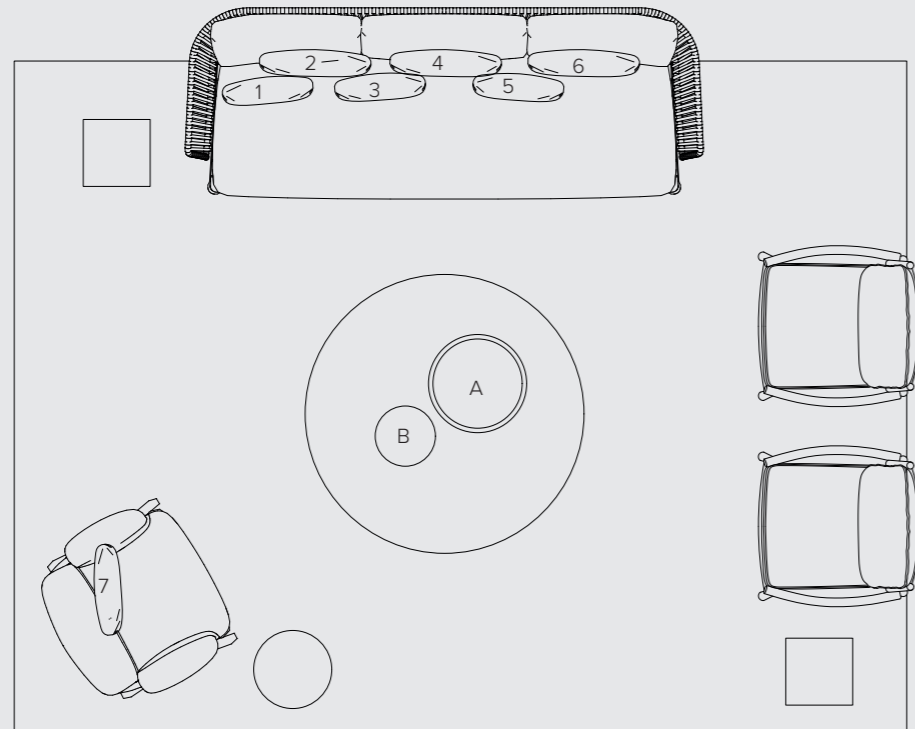

ITEM	ART.NR.	QTY	DESCRIPTION	FINISH
base	C06209S-B173W + C06209BSET-B173W C05012-B154W	1	Mood - 3-seater CU	Taman Poivre
		1	Nomad - lounge chair CU	Natural Seashell
	C07512B-E48W + C07512S-E48W +	2	Ukiyo - lounge chair CU	Knit Dark Copper
deco 1	C01713B-B154W	1	Deco cushion 42,5x31,5 cm	Natural Seashell
deco 2	C0002P-E27-B12W	1	Deco cushion 50x50 cm	Gaelic Mushroom piping Linen
deco 3	C0001-E29W	1	Deco cushion 40x40 cm	Gaelic Dark Copper
deco 4	C0002-B154W	1	Deco cushion 50x50 cm	Natural Seashell
deco 5	C01713BP-E27-B12W	1	Deco cushion 42,5x31,5 cm	Gaelic Mushroom piping Linen
deco 6	C0002P-E48-B12W	1	Deco cushion 50x50 cm	Knit Dark Copper piping Linen
deco 7	C0001P-E48-B12W	1	Deco cushion 40x40 cm	Knit Dark Copper piping Linen

CUSHIONS / STYLING

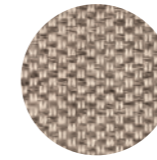

B173 Taman Poivre

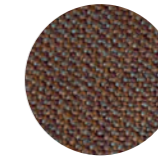

E48 Knit Dark Copper

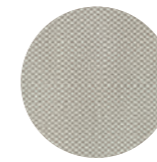

B154 Natural Seashell

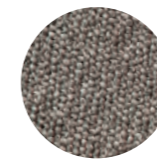

E27 Gaelic Mushroom

ITEM	DESCRIPTION
A	Cioto bowl - special marble, Michaël Verheyden
B	Caillou M - dark brown glass, When Objects Works



© Michaël Verheyden



© When Objects Work



LOUNGING



SET 5 - NODI SOFA

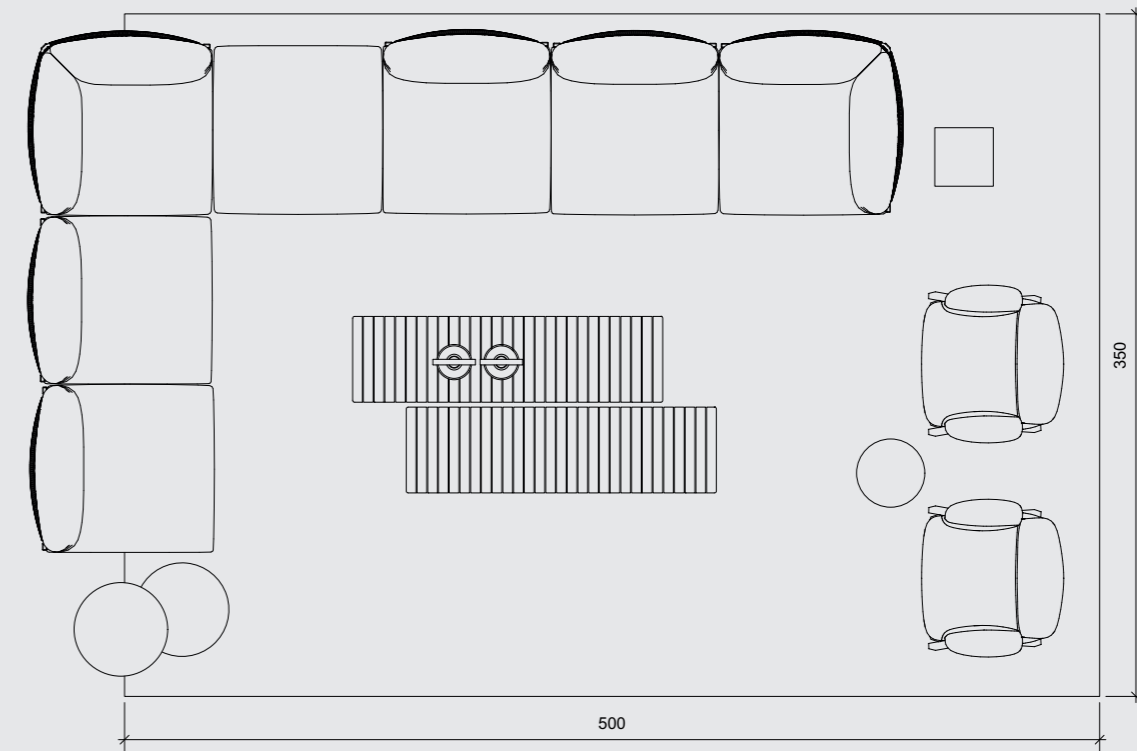

ART. NR.	QTY	DESCRIPTION	FINISH
01953-89-10	1	Nodi - left arm element	Wenge/linen
01954-89-10	1	Nodi - right arm element	Wenge/linen
01950-89-10	4	Nodi - single module	Wenge/linen
01955-89	1	Nodi - pouf	Wenge/linen
05012	1	Nomad - lounge chair	Teak
01732	1	Vis à Vis - low coffee table	Teak
06176-89	1	Natal alu x - side table dia 35cm	Wenge
04281-TV	1	Otto - side table low 48	Teak / travertine
D8300	1	Dunes - side table 48	Teak
D8102	1	Roots - side table	Teak
D2003-10-350x500	1	Shindi outdoor rug 350x500 cm	Linen

SET 5 - NODI SOFA

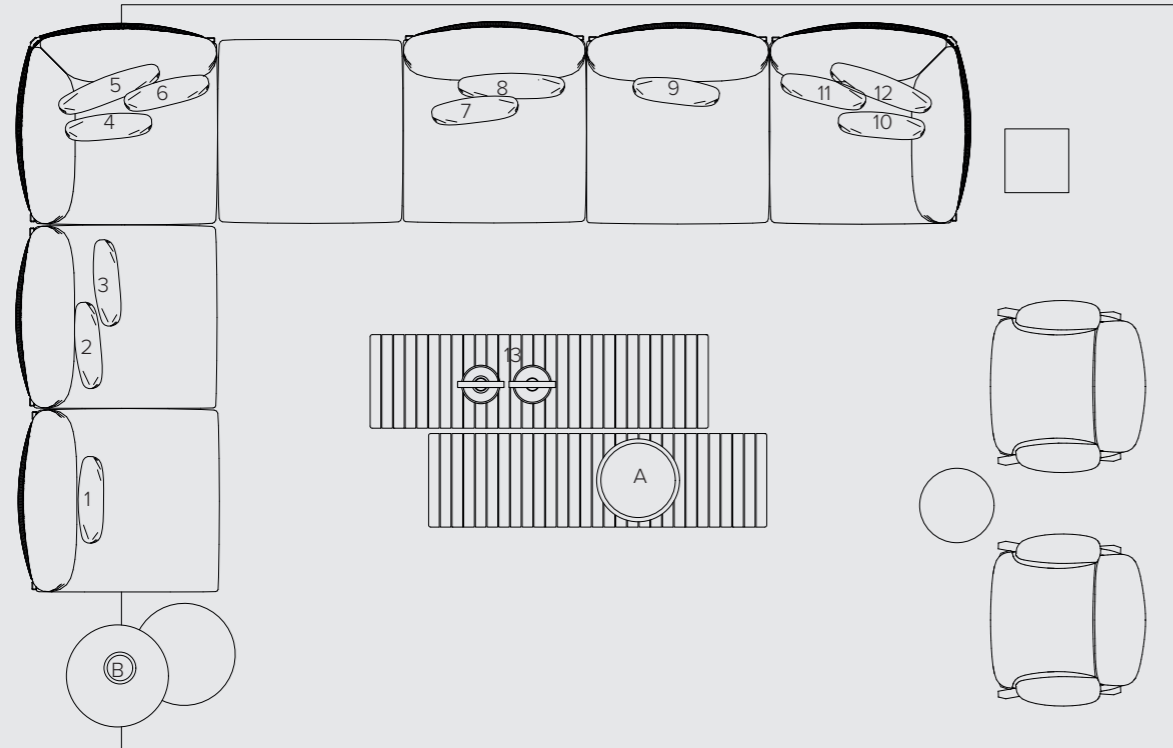

ITEM	ART. NR.	QTY	DESCRIPTION	FINISH
base	C01902S-B10W	7	Nodi - seat CU	Twist Linen
	C01901B-B10W	2	Nodi - corner back CU	Twist Linen
	C01902B-B10W	4	Nodi - back CU	Twist Linen
	C05012-B172W	2	Nomad - CU	Taman Basalt
deco 1	C0002-B172W	1	Deco 50x50 cm	Taman Basalt
deco 2	C0001-64W	1	Deco 40x40 cm	Natte Nature grey
deco 3	C01713BP-E25-B111W	1	Deco 42,5x31,5 cm	Gaelic Sandstone piping Canvas Tweed Brown
deco 4	C0001-64W	1	Deco 40x40 cm	Natte Nature grey
deco 5	C0002P-E25-B111W	1	Deco 50x50 cm	Gaelic Sandstone piping Canvas Tweed Brown
deco 6	C0001-B172W	1	Deco 40x40 cm	Taman Basalt
deco 7	C0001-64W	1	Deco 40x40 cm	Natte Nature grey
deco 8	C0002P-E25-B111W	1	Deco 50x50 cm	Gaelic Sandstone piping Canvas Tweed Brown
deco 9	C01713B-B172W	1	Deco 42,5x31,5 cm	Taman Basalt
deco 10	C01713BP-E25-B111W	1	Deco 42,5x31,5 cm	Gaelic Sandstone piping Canvas Tweed Brown
deco 11	C0001-64W	1	Deco 40x40 cm	Natte Nature grey
deco 12	C0002-B172W	1	Deco 50x50 cm	Taman Basalt
deco 13	D09010-89	2	Luna Lantern	Wengé

CUSHIONS / STYLING



B10 Twist Linen

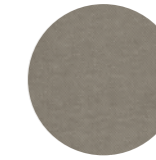

64 Natte Nature Grey

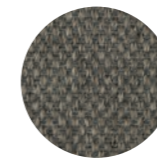

B172 Taman Basalt



E25 Gaelic Sanstone

ITEM DESCRIPTION

A	Bowl dia 39 - German Limestone - Nicolas Schuybroek for When Objects Work
B	Caillou S - green glass, When Objects Works

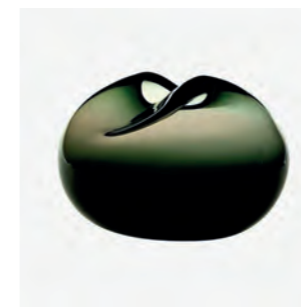

© Michaël Verheyden



© When Objects Work



LOUNGING



SET 6 - NATAL ALU SOFA

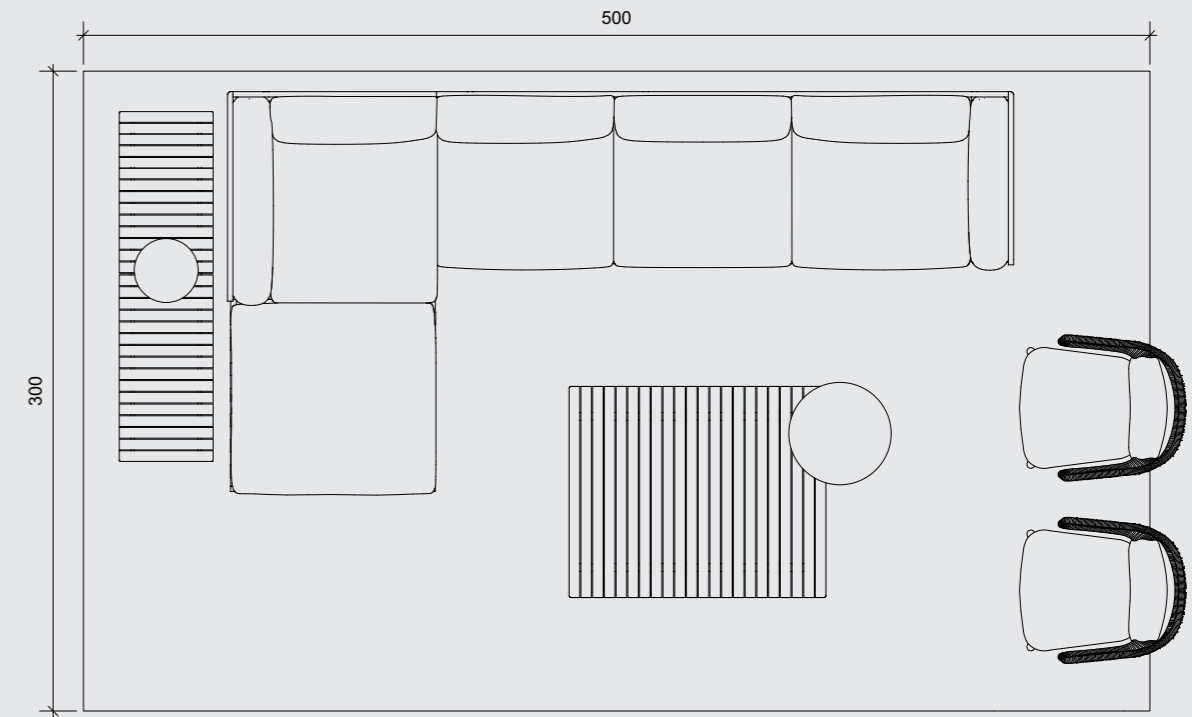

ART. NR.	QTY	DESCRIPTION	FINISH
05839LS-10	1	Natal alu - left arm extension 3-seater	Linen
05804-10	1	Natal alu - meridienne right	Linen
02312-10T-10	2	Senja - lounge chair	Teak / Linen
01734	1	Vis à vis - bench	Teak
D8300-TZ	1	Dunes - side table	Terrazzo
01784	1	Vis a Vis - coffee table 99x120	Teak
D2003-10-300x500	1	Shindi - outdoor rug 300x500	Linen

SET 6 - NATAL ALU SOFA

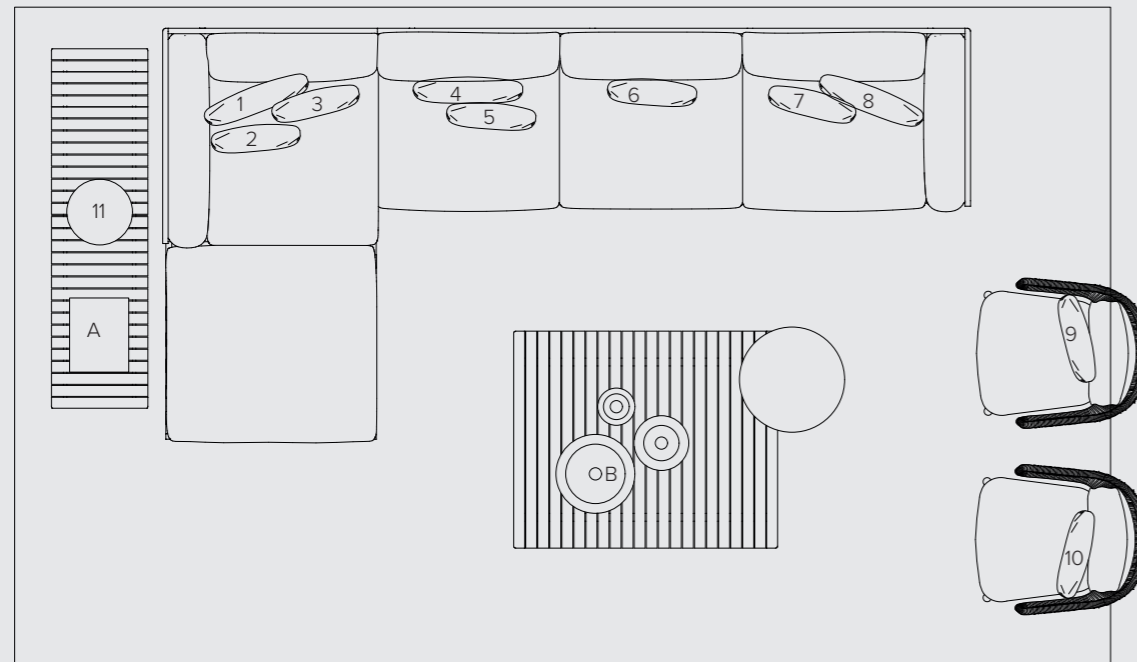

ITEM	ART.NR.	QTY	DESCRIPTION	FINISH
base	C05839LSH-E25W	1	Natal alu - left arm extn 3-seater CU	Gaelic Sandstone
	C05804-E25W	1	Natal alu - meridienn right CU	Gaelic Sandstone
	C02312S-F01W + C02312B-F01W	2	Senja - lounge chair seat CU	Sujan Hemp
deco 1	C0002P-B15-B118	1	Deco 50x50 cm	Washed Linen piping Canvas Lace
deco 2	C01713B-F01	1	Deco 42,5x31,5 cm	Sujan Hemp
deco 3	C0001P-E22-B118	1	Deco 40x40 cm	Gaelic Pearl piping Canvas Lace
deco 4	C0002-F01	1	Deco 50x50 cm	Sujan Hemp
deco 5	C0001P-B15-B118	1	Deco 40x40 cm	Washed Linen piping Canvas Lace
deco 6	C01713B-B12	1	Deco 42,5x31,5 cm	Linen
deco 7	C0001-E22	1	Deco 40x40 cm	Gaelic Pearl piping Canvas Lace
deco 8	C0002-B12W	1	Deco 50x50 cm	Linen
deco 9	C0001P-B15-B118	1	Deco 40x40 cm	Washed Linen piping Canvas Lace
deco 10	C0001P-B15-B118	1	Deco 40x40 cm	Washed Linen piping Canvas Lace
deco 11	D080240S-10	1	Madame Latoque standing 40 cm	Linen

CUSHIONS / STYLING



E25 Gaelic Sandstone



F01 Sujan Hemp

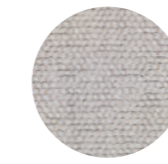

E22 Gaelic Pearl

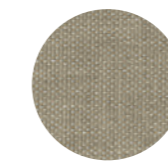

B15 Washed Linen

ITEM	DESCRIPTION
A	Works 2009-2018 - Vincent van Duysen
B	Marble plate & marble vase - Michaël Verheyden



© Michaël Verheyden



© Vincent van Duysen



LOUNGING



SET 7 - SENJA SOFA

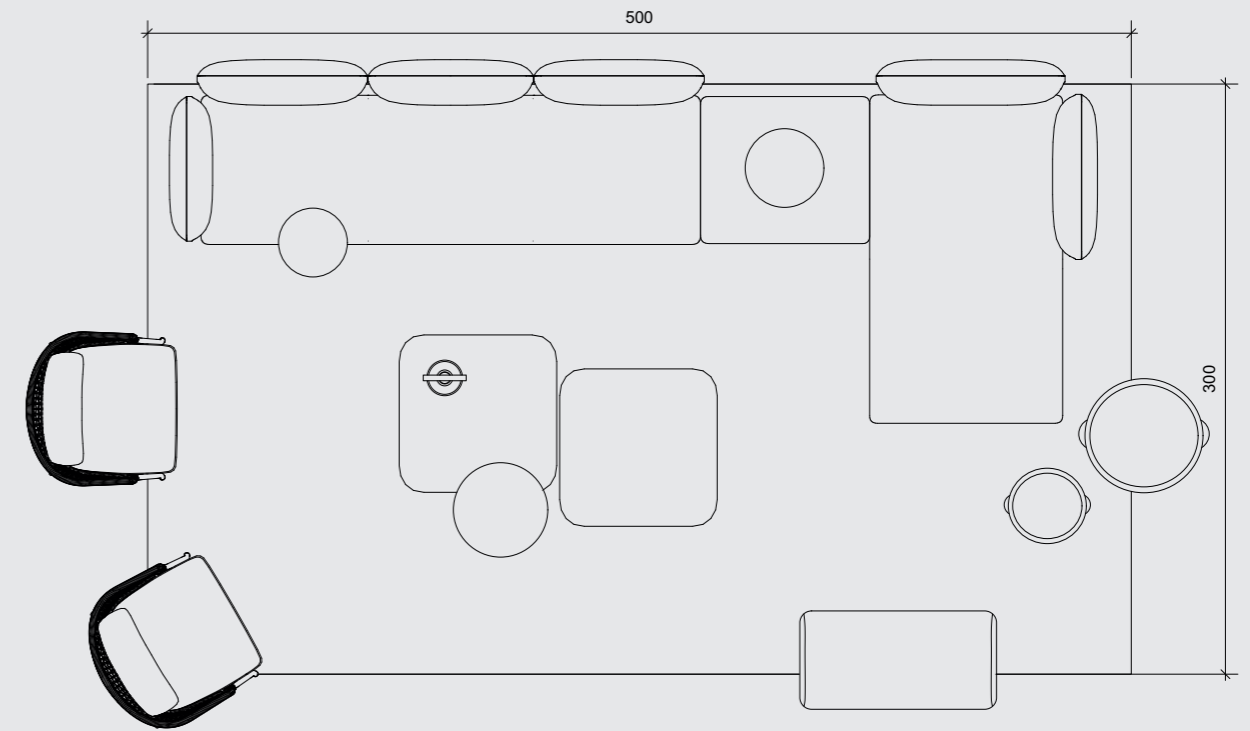

ART. NR.	QTY	DESCRIPTION	FINISH
023913-10-T	1	Senja sofa - regular 3-seater R arm low	Teak / Linen
023204-10-T	1	Senja - coffee table	Teak / Linen
023302-10-T	1	Senja - meridienne left arm low	Teak / Linen
01682-10	2	Tao - coffee table	Concrete Linen
01102-10-10	2	CTR - lounge chair	Linen / Linen
D8300	1	Dunes - side table	Teak
05584-12	1	Mai - pouf 50x100	Hemp
D5026-10	1	Drops - side table dia 40 cm	Linen
D2003-12-300x500	1	Shindi - outdoor rug 300x500 cm	Hemp

SET 7 - SENJA SOFA

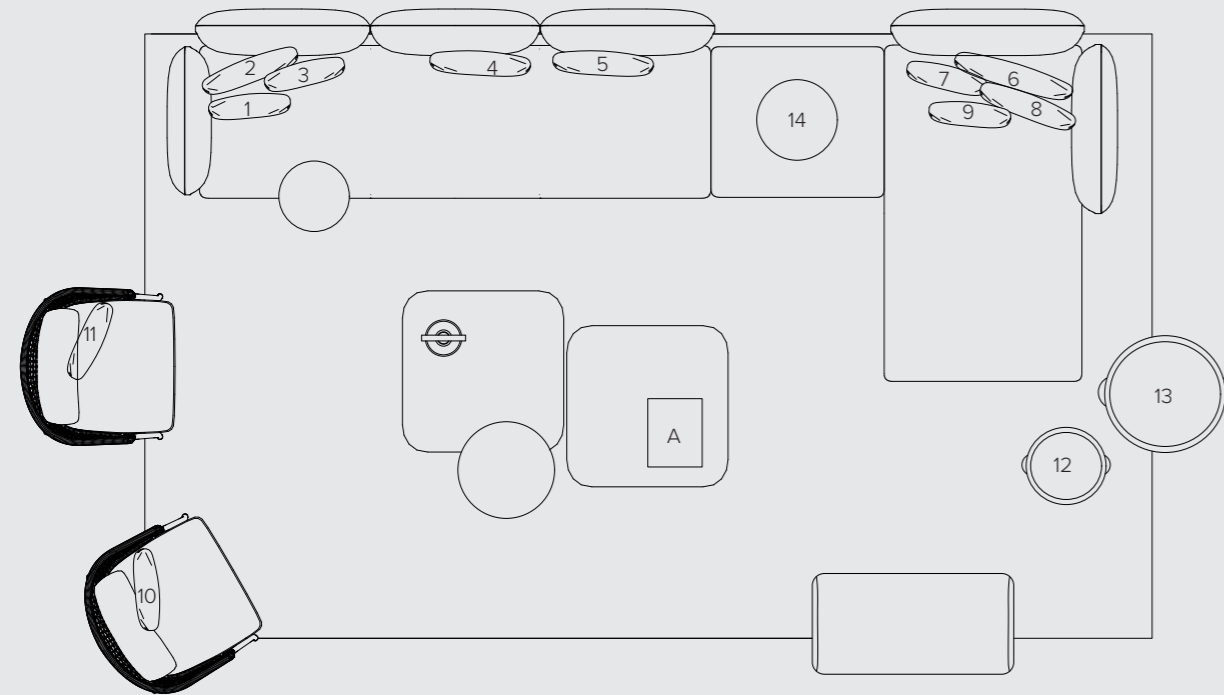

ITEM	ART. NR.	QTY	DESCRIPTION	FINISH
base	C023913-B144W	1	Senja sofa - regular 3-seater R arm low CU	Rustic Weave Cord
	C023302-B144W	1	Senja - meridienne left arm low CU	Rustic Weave Cord
	C01102S-F19W +C01100BCA-F19W	2	CTR - lounge chair CU	Naram Pearl
deco 1	C0001-F19W	1	Deco 40x40 cm	Naram Pearl
deco 2	C0002P-E45-B12W	1	Deco 50x50 cm	Knit Mellow Ochre piping Linen
deco 3	C0001-B174W	1	Deco 40x40 cm	Taman Linen
deco 4	C0002-F19W	1	Deco 50x50 cm	Naram Pearl
deco 5	C0002-B174W	1	Deco 50x50 cm	Taman Linen
deco 6	C0003-F19W	1	Deco 60x60 cm	Naram pearl
deco 7	C0001P-E45-B12W	1	Deco 40x40 cm	Knit Mellow Ochre piping Linen
deco 8	C0002-B174W	1	Deco 50x50 cm	Taman Linen
deco 9	C01713B-F19W	1	Deco 42,5x31,5 cm	Naram Pearl
deco 10	C01713BP-E45-B12W	1	Deco 42,5x31,5 cm	Knit Mellow Ochre piping Linen
deco 11	C01713BP-E45-B12W	1	Deco 42,5x31,5 cm	Knit Mellow Ochre piping Linen
deco 12	D3020-10W	1	Gobi basket S	Linen
deco 13	D3010-10W	1	Gobi Basket M	Linen
deco 14	D080330S-10	1	Madame Cachet standing 30 cm	Linen

CUSHIONS / STYLING

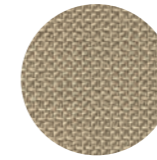

B144 Rustic Weave Cord



F19 Naram pearl

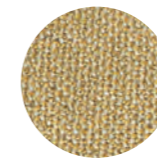

E45 Knit Mellow Ochre

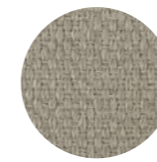

B174 Taman Linen

ITEM	DESCRIPTION
A	Volume One - Selected Works - Nicolas Schuybroek

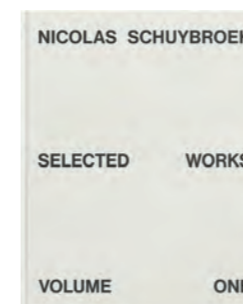

© Hatje Cantz



LOUNGING



SET 8 - VIS À VIS SOFA

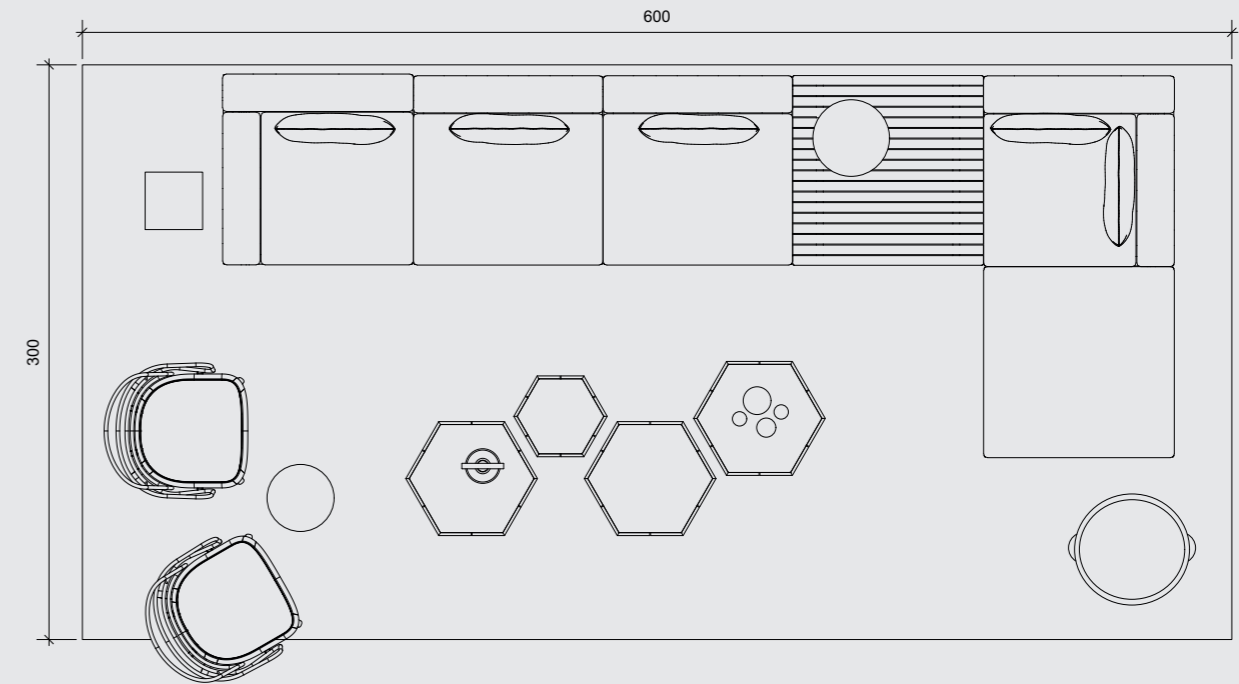

ART. NR.	QTY	DESCRIPTION	FINISH
01701R	1	Vis a Vis - corner module right arm	Teak
01728	1	Vis a Vis - extension module double	Teak
01781	1	Vis a Vis - coffee table	Teak
01703S	1	Vis a Vis - meridienne left short arm	Teak
02712-T-10	2	Suro - lounge chair	Teak / Linen
D5040-L10	3	Hexagon - coffee table low	Teak / Lava Linen
D5041-L10	1	Hexagon - side table high	Teak / Lava Linen
D8102	1	Roots - side table	Teak
06176-20	1	Natal Alu x - coffee table dia 35 cm	Clay
D2003-10-300x400	1	Shindi - outdoor rug 300x400 cm	Linen

SET 8 - VIS À VIS SOFA

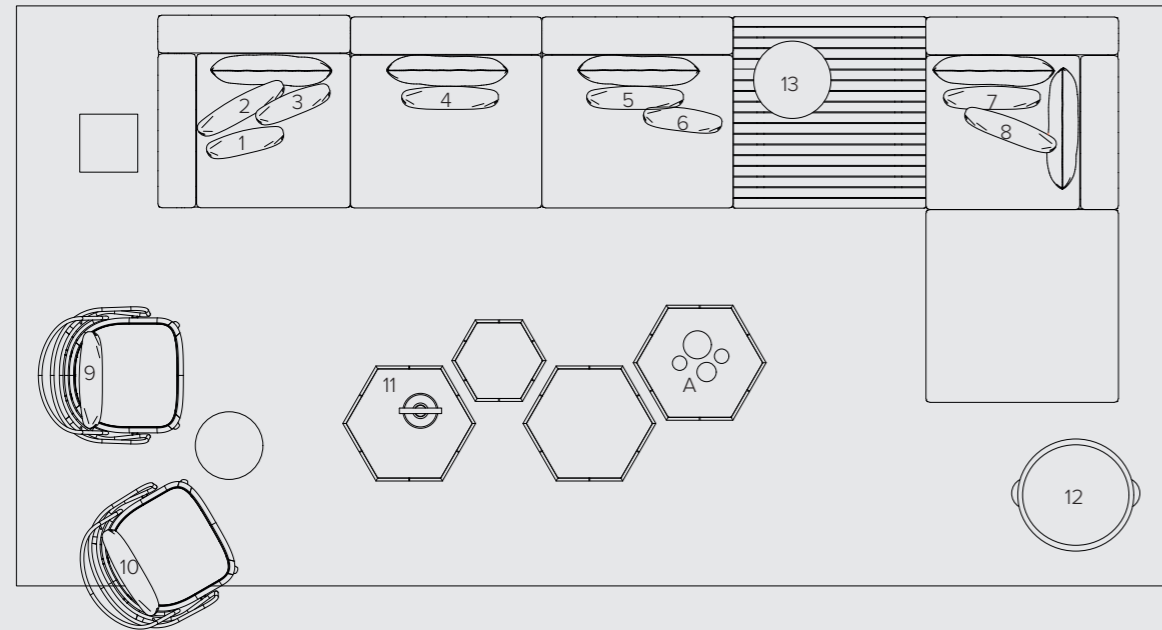

ITEM	ART. NR.	QTY	DESCRIPTION	FINISH
base	C01701-E23W	1	Vis a Vis - corner right arm CU	Gealic Glacier
	C01728-E23W	1	Vis a Vis - extension double CU	Gealic Glacier
	C01703S-E23W	1	Vis a Vis - meridienn left short arm	Gealic Glacier
	C02712S-E34W	2	Suro - lounge chair CU	Knit silverstone
deco 1	C01713B-E34W	1	Deco 42,5x31,5 cm	Knit silverstone
deco 2	C0001P-E23-B12W	1	Deco 40x40 cm	Gaelic Glacier piping Linen
deco 3	C0002-B55W	1	Deco 50x50 cm	Linen Scisto
deco 4	C0001P-65-B12W	1	Deco 40x40 cm	Natte Basalt piping Linen
deco 5	C0002-B55W	1	Deco 50x50 cm	Linen Scisto
deco 6	C0001-E34W	1	Deco 40x40 cm	Knit silverstone
deco 7	C0002P-65-B12W	1	Deco 50x50 cm	Natte Basalt piping Linen
deco 8	C01713BP-E23-B12W	1	Deco 42,5x31,5 cm	Gaelic Glacier piping Linen
deco 9	C0002-E55W	1	Deco 50x50 cm	Linen Scisto
deco 10	C0002-E55W	1	Deco 50x50 cm	Linen Scisto
deco 11	D09010-89	1	Luna Lantern	Wengé
deco 12	D3010-10W	1	Gobi Basket M	Linen
deco 13	D080130S-89	1	Monsieur Lebonnet standing 40 cm	Wengé

CUSHIONS / STYLING



E23 Gealic Glacier

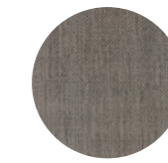

B55 Linen Scisto

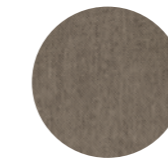

65 Natte Basalt piping Linen



E34 Knit silverstone

ITEM DESCRIPTION

A T-light - S & M - Alabaster - Michaël Verheyden



© Michaël Verheyden



LOUNGING



SET 9 - PURE SOFA

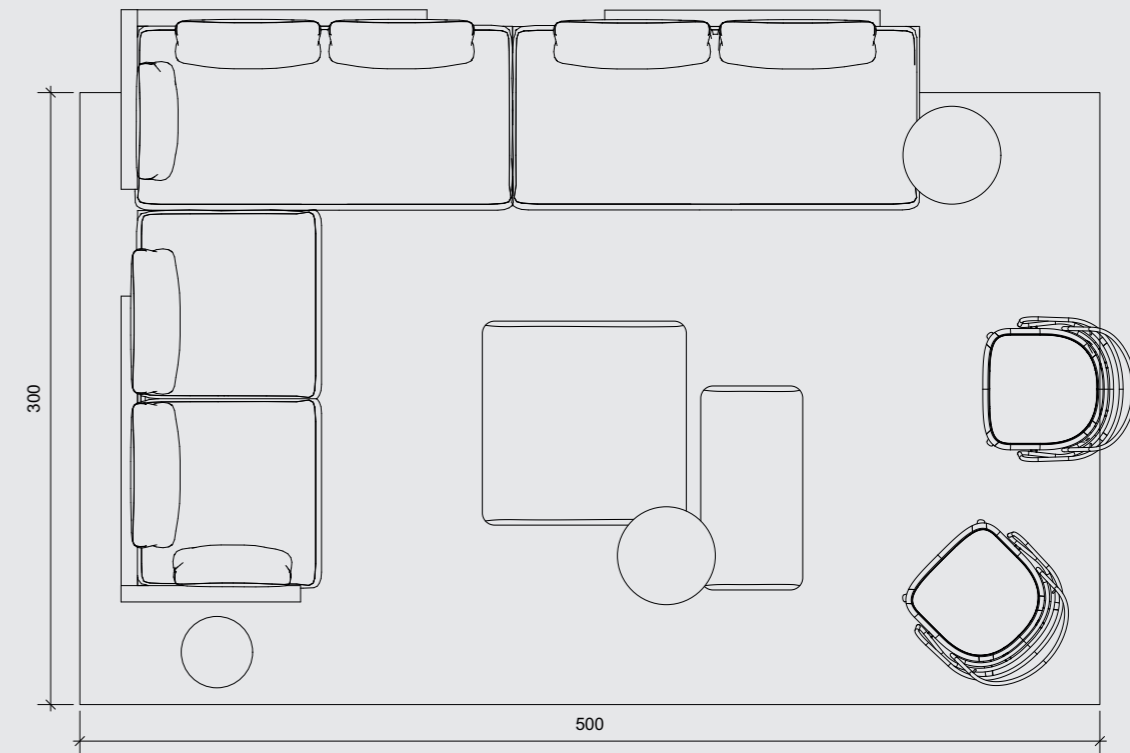

ART. NR.	QTY	DESCRIPTION	FINISH
01204	2	Pure sofa - right arm	Teak
01228	1	Pure sofa - extension	Teak
02712-20-12	2	Suro - lounge chair	Clay / Hemp
04280-T	1	Otto - side table high	Teak / Teak
05584-12	1	Mai - pouf 50x100	Hemp
05582-12	1	Mai - pouf 100x100	Hemp
D8300-TZ	1	Dunes - side table 60	Terrazzo
06176-12	1	Natal Alu - x table round	Clay
D2003-10-300x500	1	Shindi - outdoor rug 300x500 cm	Hemp

SET 9 - PURE SOFA

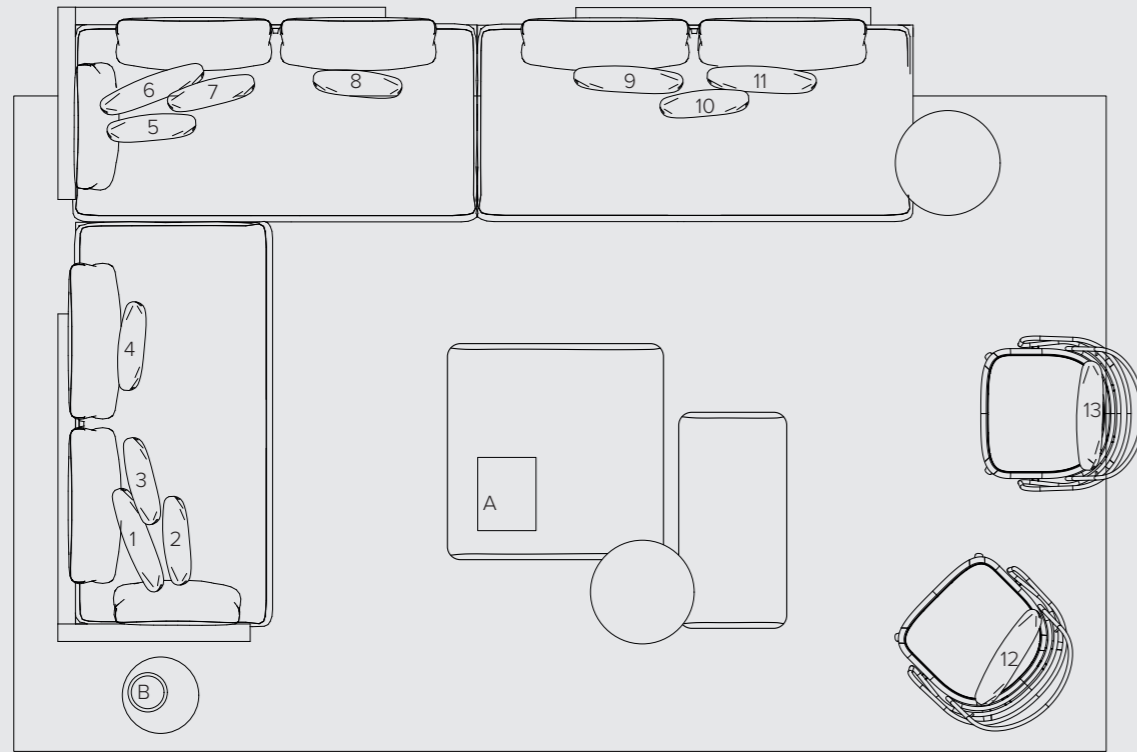

ITEM	ART. NR.	QTY	DESCRIPTION	FINISH
base	C01205CA-E22W	2	Pure sofa - right arm CU	Gaelic Pearl
	C01228CA-E22W	1	Pure sofa - extension CU	Gaelic Pearl
	C02712S-B174W	2	Suro - lounge chair CU	Taman Linen
deco 1	C0002P-B184-B118W	1	Deco 50x50 cm	Taman Linen piping Canvas Lace
deco 2	C01713BP-B184-B118W	1	Deco 42,5x31,5 cm	Tagika Fresco piping Canvas Lace
deco 3	C0001-E22W	1	Deco 40x40 cm	Knit Morning Dew
deco 4	C0001-B111W	1	Deco 40x40 cm	Canvas Tweed Brown
deco 5	C0001-E22W	1	Deco 40x40 cm	Knit Morning Dew
deco 6	C0002P-B184-B118W	1	Deco 50x50 cm	Tagika Fresco piping Canvas Lace
deco 7	C0001-B111W	1	Deco 40x40 cm	Canvas tweed Brown
deco 8	C01713BP-B174-B118W	1	Deco 42,5x31,5 cm	Taman Linen piping Canvas Lace
deco 9	C0002-E22W	1	Deco 50x50 cm	Knit Morning Dew
deco 10	C0001P-B184-B118W	1	Deco 40x40 cm	Tagika Fresco piping Canvas Lace
deco 11	C0002P-B174-B118W	1	Deco 50x50 cm	Taman Linen piping Canvas Lace
deco 12	C0002-B111W	1	Deco 50x50 cm	Canvas Tweed Brown
deco 13	C0002-B111W	1	Deco 50x50 cm	Canvas Tweed Brown

CUSHIONS / STYLING



E22 Gaelic Pearl



B111 Canvas Tweed Brown

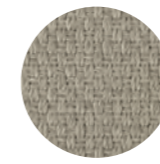

B184 Taman Linen



E22 Knit Morning Dew

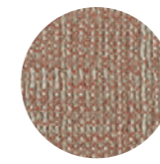

B184 Tagika Fresco

ITEM DESCRIPTION

- A Seeking Sanctuary - private residences for true relaxation, Beta Plus
- B Mero & Cali Bowl - oak - Michaël Verheyden



© Michaël Verheyden



© BETA-PLUS PUBLISHING



DINING

What's a dinner party without plenty of chairs and room at the table for everyone? Tribù dining creates an outdoor space that inspires you to sit back and relax for casual low dining, or more formal dinner, without compromising on comfort and design. Our contemporary and understated aesthetic brings elegance to any outdoor dining setting, whether it's with a spectacular view, or in a more discreet environment.



DINING



SET 10 - TAO DINING TABLE

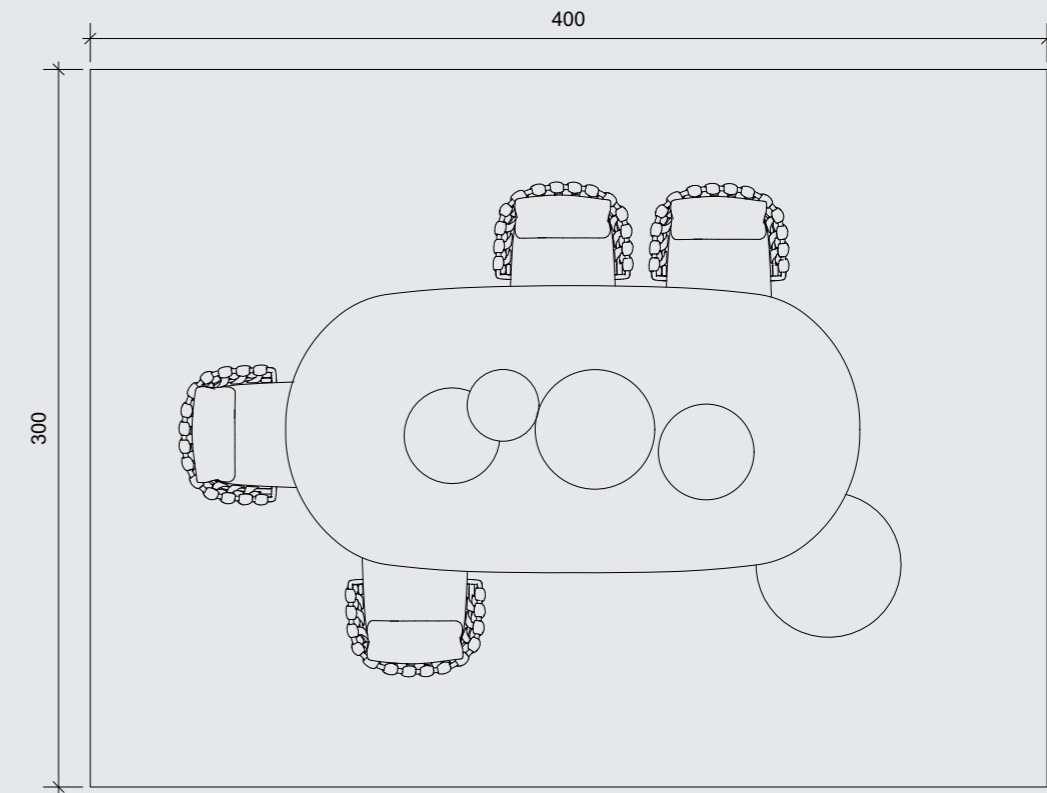

ART. NR.	QTY	DESCRIPTION	FINISH
01670-10	1	Tao - dining table oval 240cm	Concrete Linen
05318-10	4	Tosca - armchair	Linen
D2003-10-300x400	1	Shindi - outdoor rug 300x400 cm	Linen

SET 10 - TAO DINING TABLE

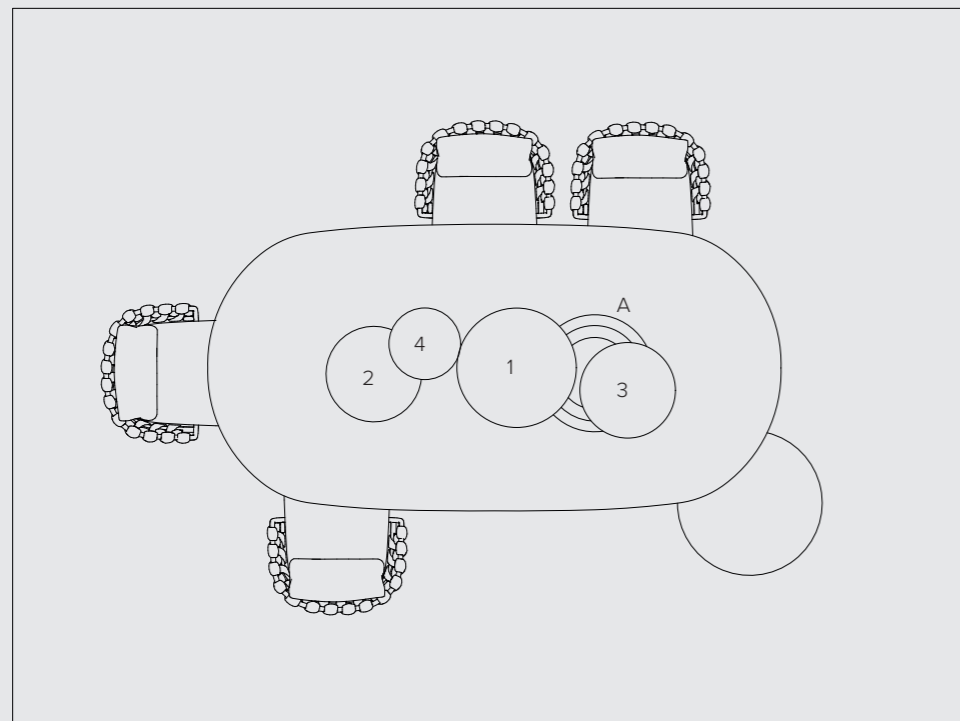

ITEM	ART.NR.	QTY	DESCRIPTION	FINISH
seat 1	C05318S-B121W	4	Tosca - armchair seat CU	Canvas Seagrass
	C05318B-E38W	4	Tosca - armchair back CU	Knit Iris
seat 2	C05032-E34W	1	Nomand - pouf S	Knit Silverstone
deco 1	D080350H-10	1	Mr. Tricot - Madame Cachet 50cm	Linen
deco 2	D080340H-10	1	Mr. Tricot - Madame Cachet 40cm	Linen
deco 3	D080440H-10	1	Mr. Tricot - Monsieur Ellipse 40 cm	Linen
deco 4	D080230H-10	1	Mr. Tricot - Madame Latoque 30 cm	Linen

CUSHIONS / STYLING

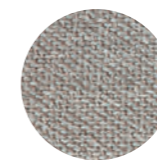

E34 Knit Silverstone

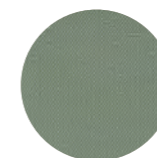

B121 Canvas Seagrass

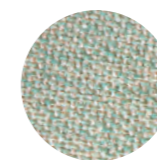

E38 Knit Iris

ITEM	DESCRIPTION
A	GY tray S,M,L - oak, Michaël Verheyden



© Michaël Verheyden



DINING



SET 11 - OTTO DINING TABLE ROUND

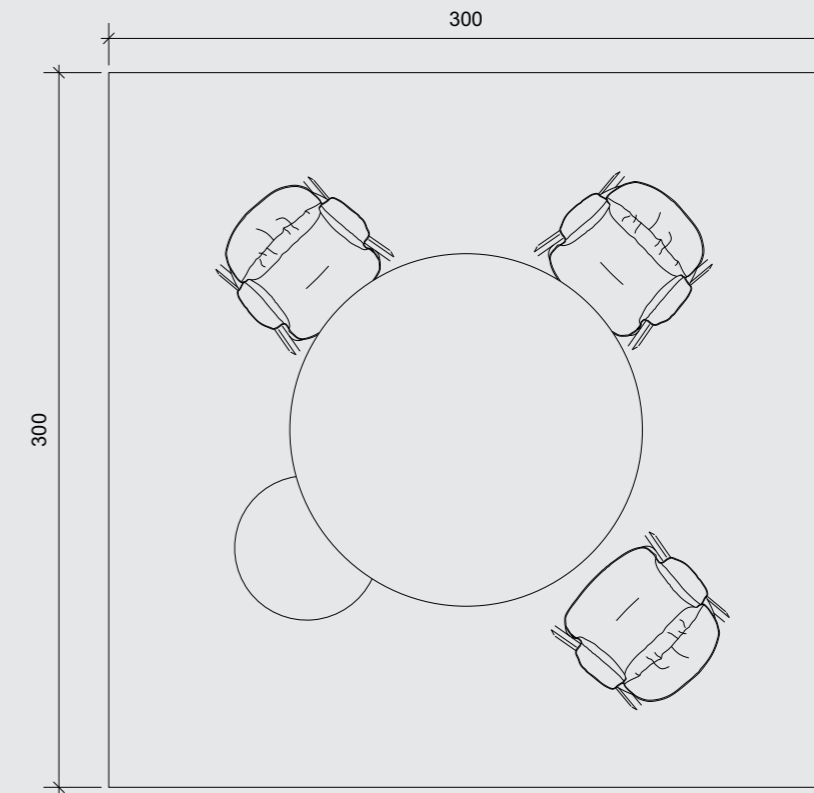

ART. NR.	QTY	DESCRIPTION	FINISH
04266-C80	1	Otto - dining table dia 148 cm	Ceramic Scisto
05018	3	Nomad - armchair	Teak
D2003-10-300x300	1	Shindi - outdoor rug 300x300 cm	Linen

SET 11 - OTTO DINING TABLE ROUND

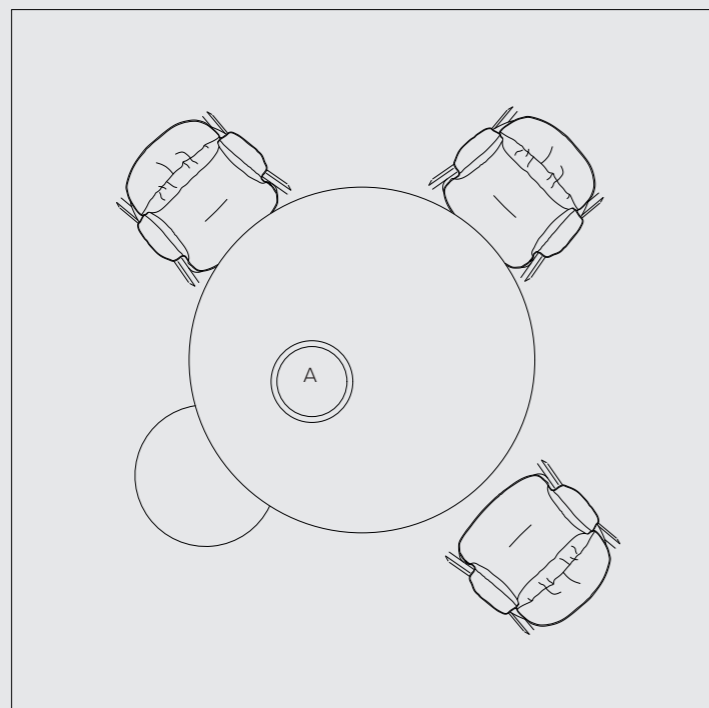

ITEM	ART.NR.	QTY	DESCRIPTION	FINISH
seat 1	C05018-E29W	3	Nomad - armchair CU	Gaelic Dark Copper
seat 2	C05032-B151W	1	Nomad - pouf S	Rustic Weave Brown

CUSHIONS / STYLING

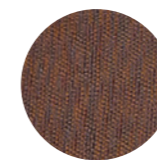

E29 Gaelic Dark Copper

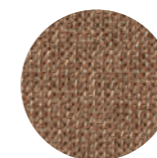

B151 Rustic Weave Brown

ITEM	DESCRIPTION
A	Bowl Ø 35 cm - limestone, John Pawson for When Objects Work



© When Objects Work



DINING



SET 12 - OTTO DINING TABLE RECTANGULAR

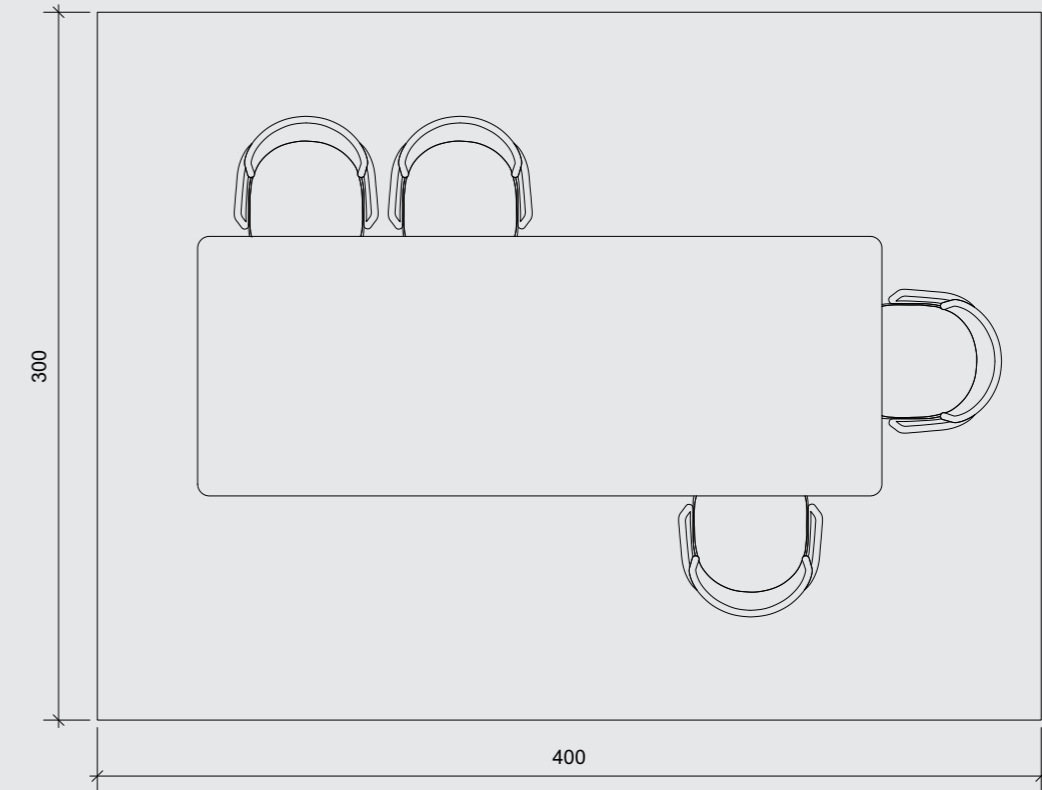

ART. NR.	QTY	DESCRIPTION	FINISH
04254-TV	1	Otto - dining table 290x110 cm	Travertin
02718-T-12	4	Suro - armchair	Teak / Hemp
D2003-10-300x400	1	Shindi - outdoor rug 300x400 cm	Linen

SET 12 - OTTO DINING TABLE RECTANGULAR

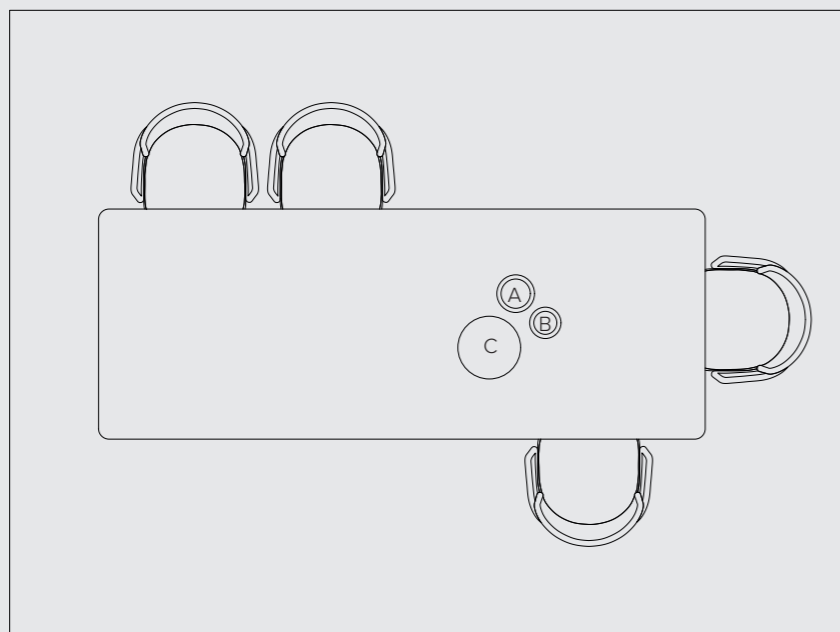

ITEM	ART.NR.	QTY	DESCRIPTION	FINISH
seat 1	C02718S-E22W	4	Suro - armchair CU	Gaelic Pearl

CUSHIONS / STYLING

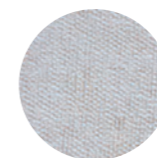

E22 Gaelic Pearl

ITEM	DESCRIPTION
A	Vase Ø 18 cm - limestone, Nicolas Schuybroek for When Objects Work
B	Vase Ø 15 cm - limestone, Nicolas Schuybroek for When Objects Work
C	Pottery Ø 30 cm - German limestone, Vincent van Duysen for When Objects Work



© When Objects Work



© When Objects Work



DINING



SET 13 - SURO DINING TABLE LANDSCAPE

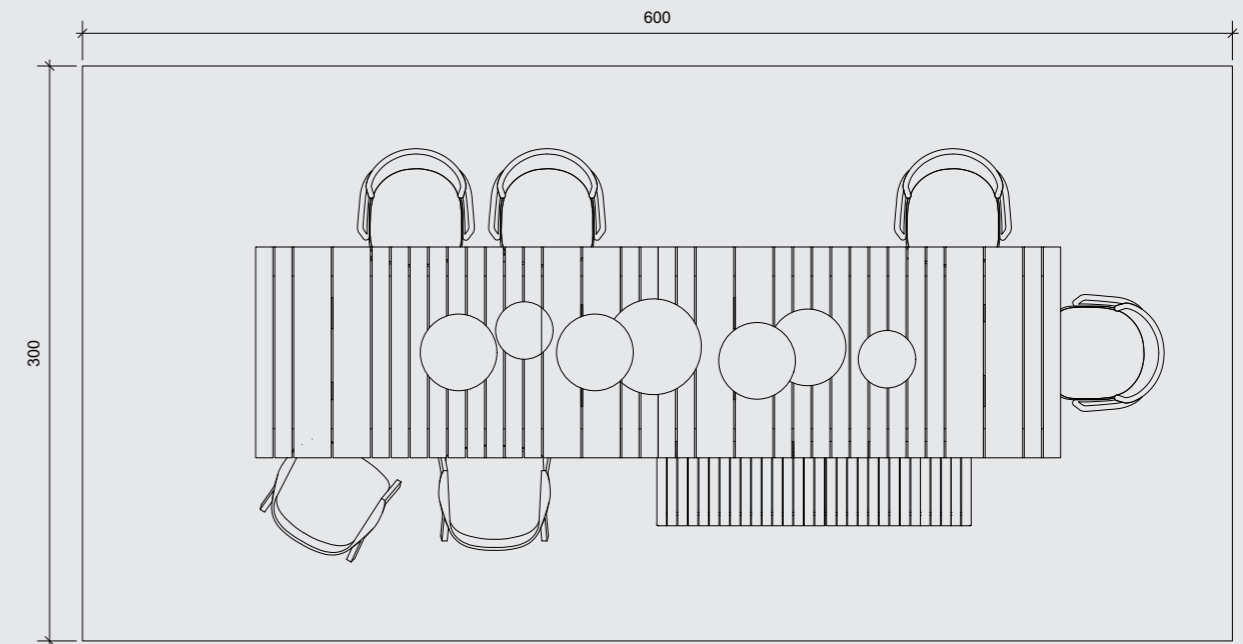

ART. NR.	QTY	DESCRIPTION	FINISH
02752-T	2	Suro - dining table 210x110 cm	Teak
02718-20-10	4	Suro - armchair	Clay / Linen
01734	1	Vis à Vis - bench	Teak
05018	2	Nomad - armchair	Teak
D2003-10-300x600	1	Shindi - outdoor rug 300x600 cm	Linen

SET 13 - SURO DINING TABLE LANDSCAPE

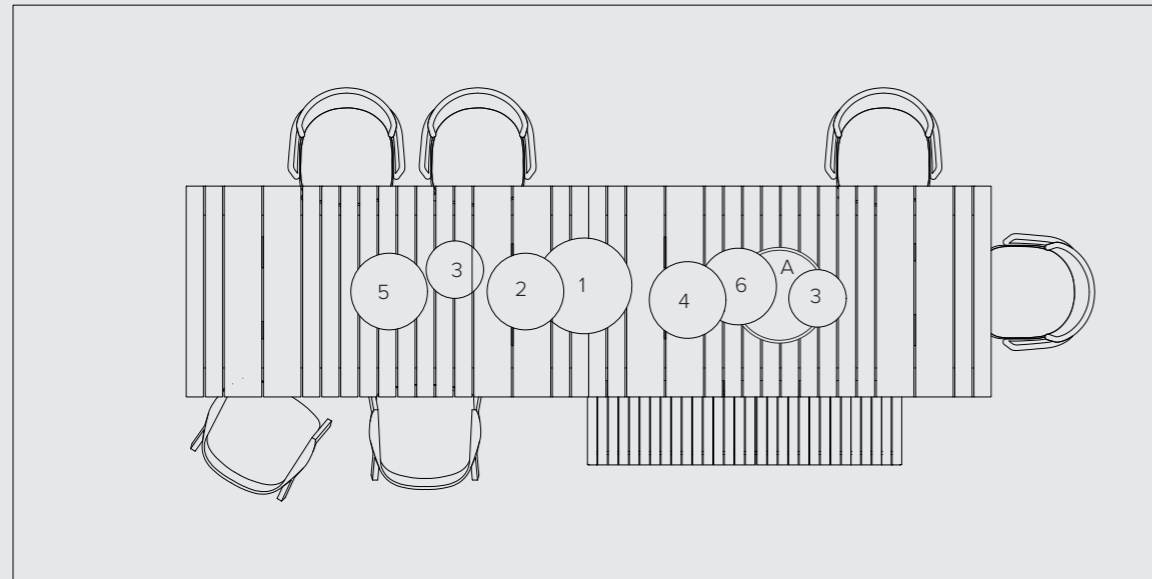

ITEM	ART.NR.	QTY	DESCRIPTION	FINISH
seat 1	C02718S-B42W	4	Suro - armchair CU	Dalsace Flax
seat 2	C01734-F19W	1	Vis à Vis - bench CU	Naram Pearl
seat 3	C05012S-E32W	2	Nomad - armchair CU	Knit Morning Dew
deco 1	D080350H-10	1	Mr. Tricot - Madame Cachet 50 cm	Linen
deco 2	D080340H-10	1	Mr. Tricot - Madame Cachet 40 cm	Linen
deco 3	D080440H-10	2	Mr. Tricot - Monsieur Ellipse 40 cm	Linen
deco 4	D080230H-10	1	Mr. Tricot - Madame Latoque 30 cm	Linen
deco 5	D080140H-10	1	Mr. Tricot - Monsieur Lebonnet 40 cm	Linen
deco 6	D080130H-10	1	Mr. Tricot - Monsieur Lebonnet 30 cm	Linen

CUSHIONS / STYLING

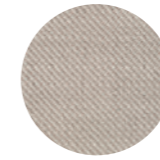

B42 Dalsace Flax



F19 Naram Pearl

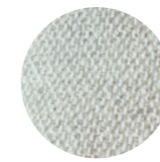

E32 Knit Morning Dew

ITEM	DESCRIPTION
A	Tray Ø 50 cm - black concrete - Bea Mombaers for Serax



© Serax



DINING



SET 14 - NOX DINING TABLE

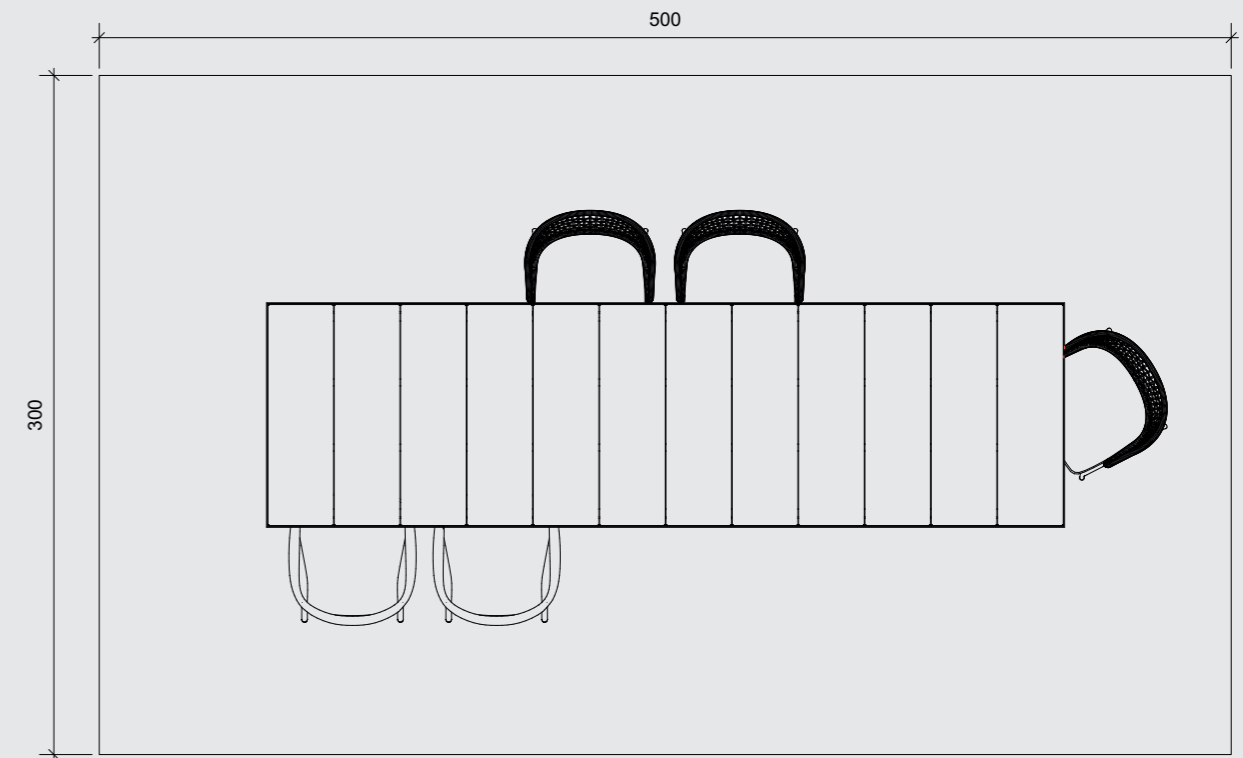

ART. NR.	QTY	DESCRIPTION	FINISH
02254-89-L30	1	Nox - dining table 352x99 cm	Wengé / Lava stone Moss
01118-89-10	3	CTR - armchair	Wengé / Linen
06518-20	2	Illum - armchair	Clay
D2003-10-300x600	1	Shindi - outdoor rug 300x600 cm	Linen

SET 14 - NOX DINING TABLE

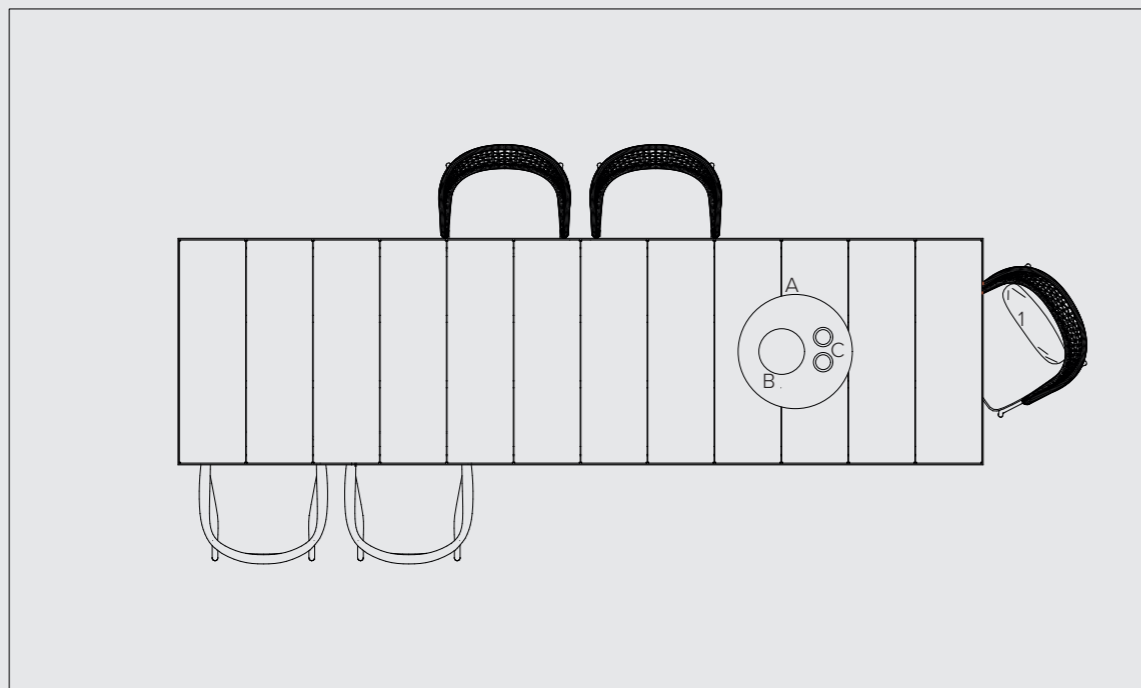

ITEM	ART.NR.	QTY	DESCRIPTION	FINISH
seat 1	C01118S-E43W	3	CTR - armchair CU	Knit Rosemary
Seat 2	C06518S-F21W	2	Illum - armchair CU	Naram Warm Cotton
deco 1	C01713B-E43	1	deco 40x40 cm	Knit Rosemary

CUSHIONS / STYLING

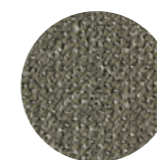

E43 Knit rosemary

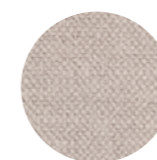

F21 Naram warm cotton

ITEM	DESCRIPTION
A	Tray Ø 50 cm - black concrete - Bea Mombaers for Serax
B	Tea pot cast iron - Black Collage - Utilise objects for Serax
C	Mug without handle - Camogreen - Sergio Herman for Serax



© Serax



© Serax



© Serax



DINING



SET 15 - AMANU DINING TABLE

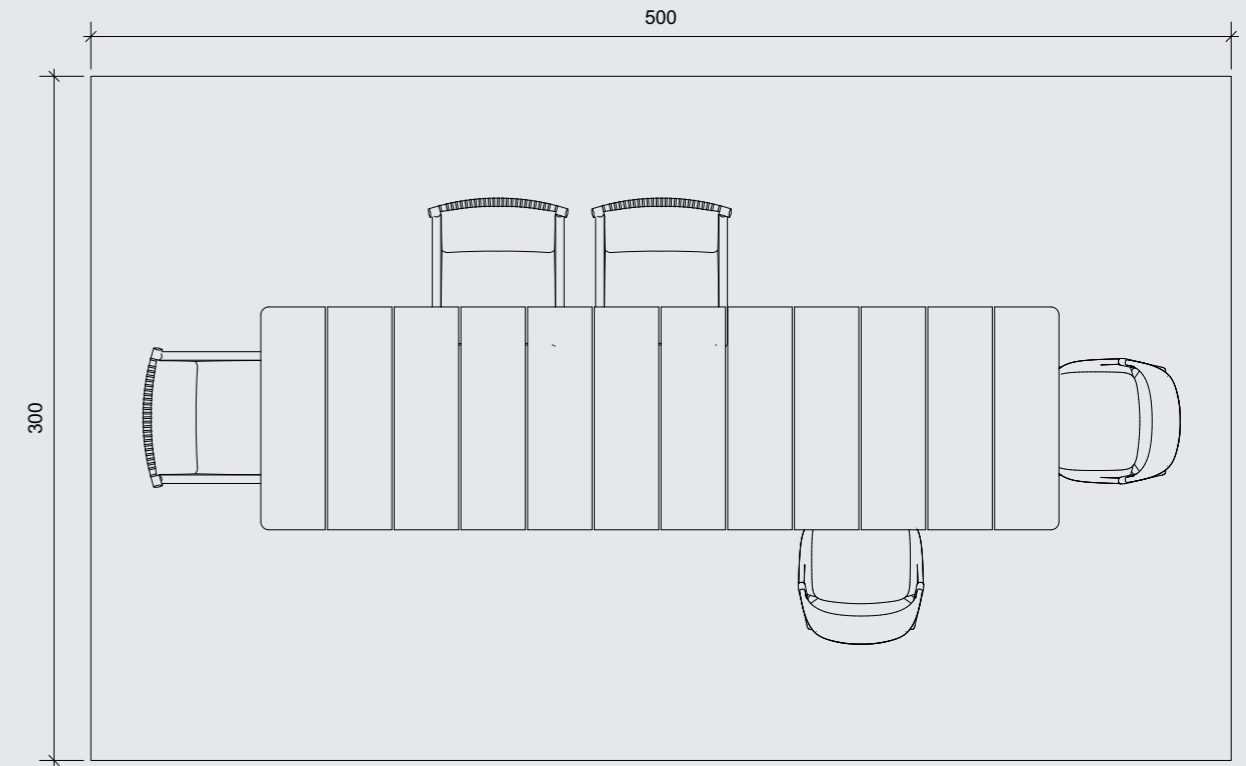

ART. NR.	QTY	DESCRIPTION	FINISH
02654-C80	1	Amanu - dining table 350x98 cm	Teak / Ceramic Scisto
02618-10	3	Amanu - armchair	Teak / Linen
02518-10	2	Elio - armchair	Teak / Linen
D2003-12-300x500	1	Shindi - outdoor rug 300x500 cm	Hemp

SET 15 - AMANU DINING TABLE

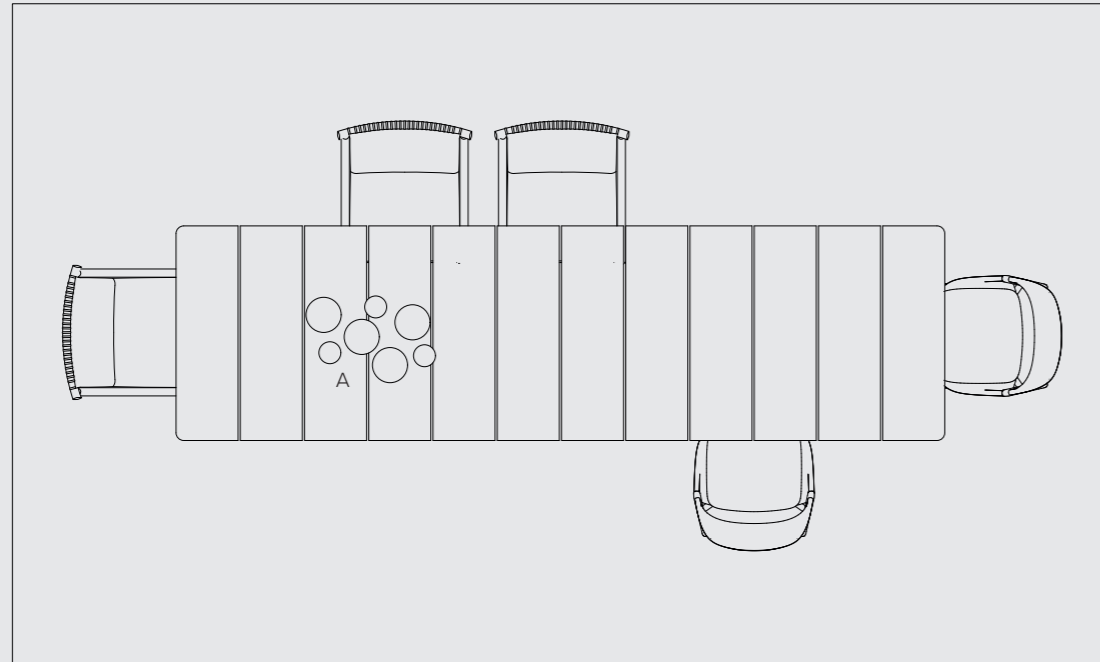

ITEM	ART.NR.	QTY	DESCRIPTION	FINISH
seat 1	C02618-F04W	3	Amanu - armchair seat and back CU	Sujan Ochre
seat 2	C02518S-E45W	3	Elio - armchair CU	Knit Mellow Ochre

CUSHIONS / STYLING

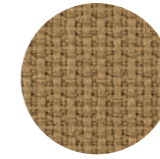

F04 Sujan Ochre

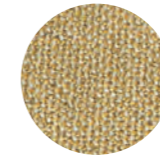

E45 Knit mellow ochre

ITEM	DESCRIPTION
A	Candle holders - John Pason - When objects work



© When Objects Work



DINING



SET 16 - UKIYO DINING TABLE

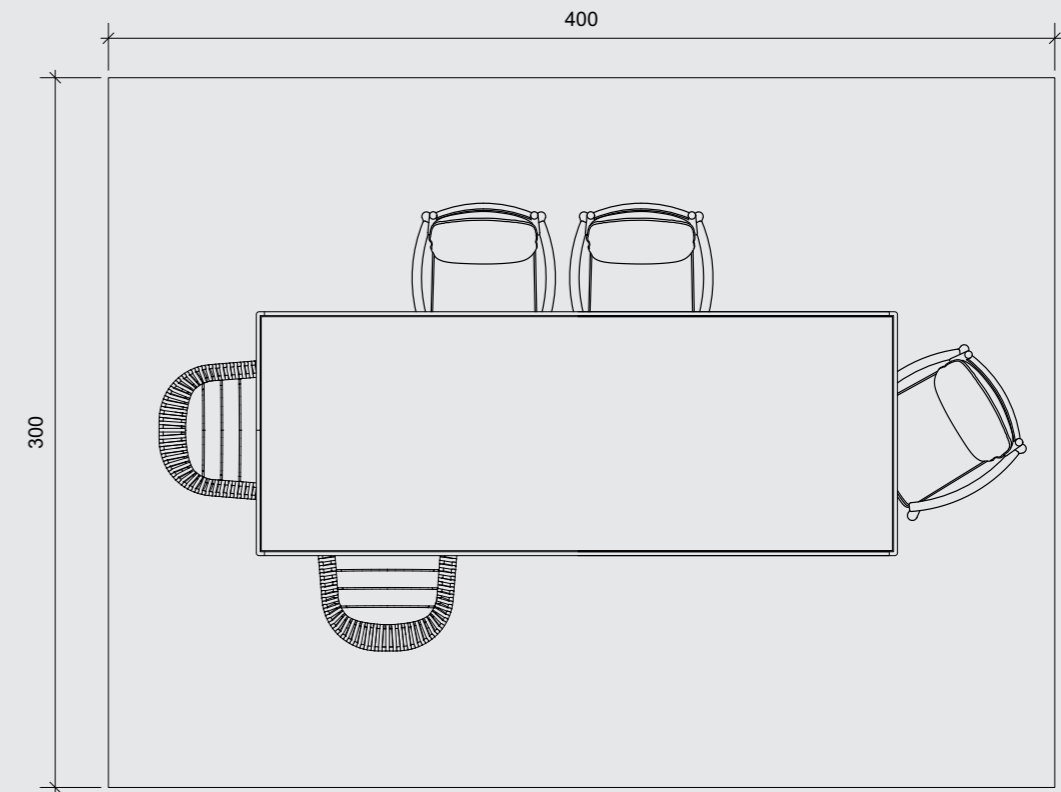

ART. NR.	QTY	DESCRIPTION	FINISH
07553-C15	1	Ukiyo - dining table 271x100 cm	Teak / Ceramic Sabbia
07518	3	Ukiyo - armchair	Teak
06218-10	2	Mood - armchair	Teak / Linen
D2003-10-300x600	1	Shindi - outdoor rug 300x600 cm	Linen

SET 16 - UKIYO DINING TABLE

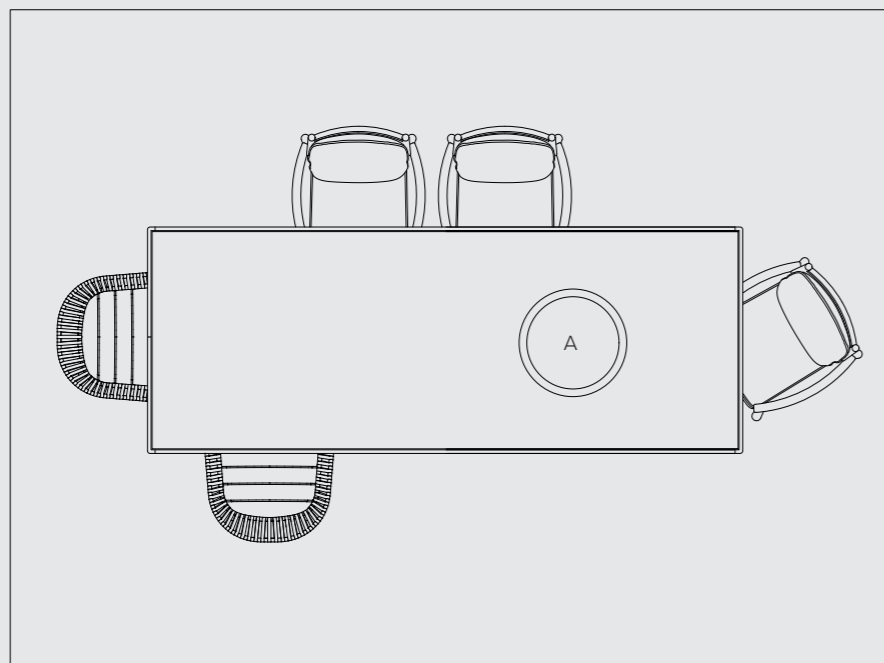

ITEM	ART.NR.	QTY	DESCRIPTION	FINISH
seat 1	C07518-E23W	3	Ukiyo - armchair CU	Gaelic Glacier
seat 2	C06218S-B184W + C06218BH-B184W	2	Mood - armchair CU	Tagika Fresco

CUSHIONS / STYLING



E23 Gaelic Glacier

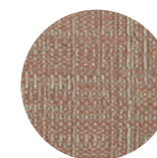

B184 Tagika Fresco

ITEM	DESCRIPTION
A	Komm, Marble - Michaël Verheyden



© Michaël Verheyden



DINING



SET 17 - SURO DINING TABLE

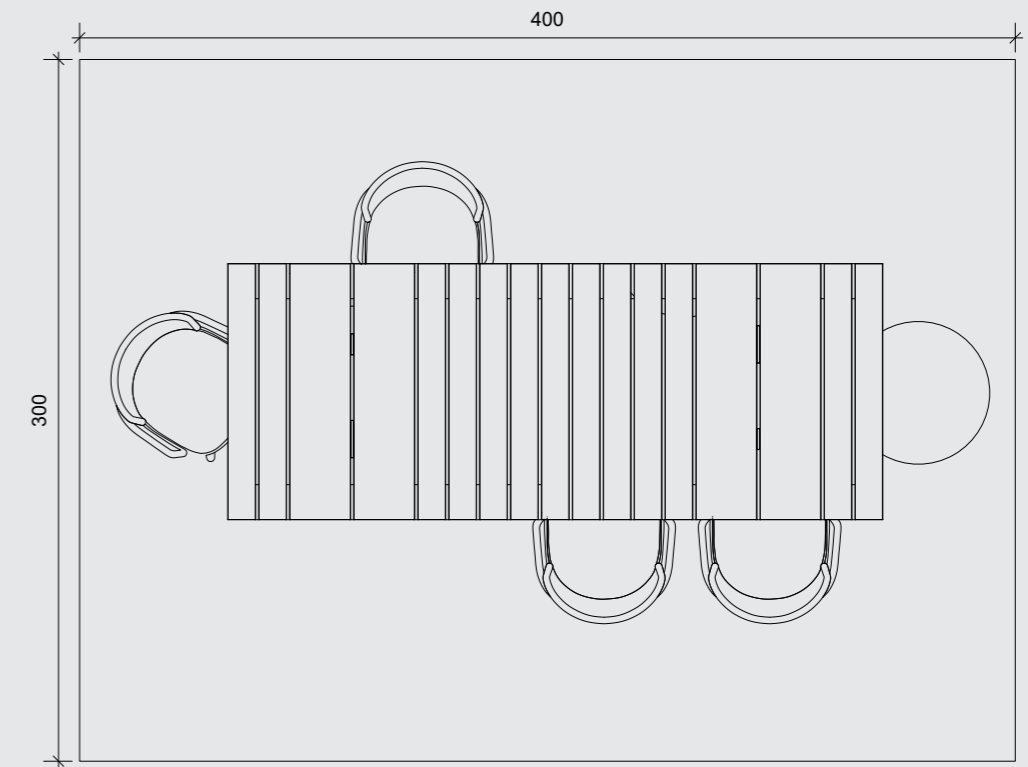

ART. NR.	QTY	DESCRIPTION	FINISH
02753-T	1	Suro - dining table 280x100 cm	Teak
02718-20-10	4	Suro - armchair	Clay / Linen
C05032W	1	Nomad - pouf S	Gaelic Glacier
D2003-10-300x600	1	Shindi - outdoor rug 300x600 cm	Linen

SET 17 - SURO DINING TABLE

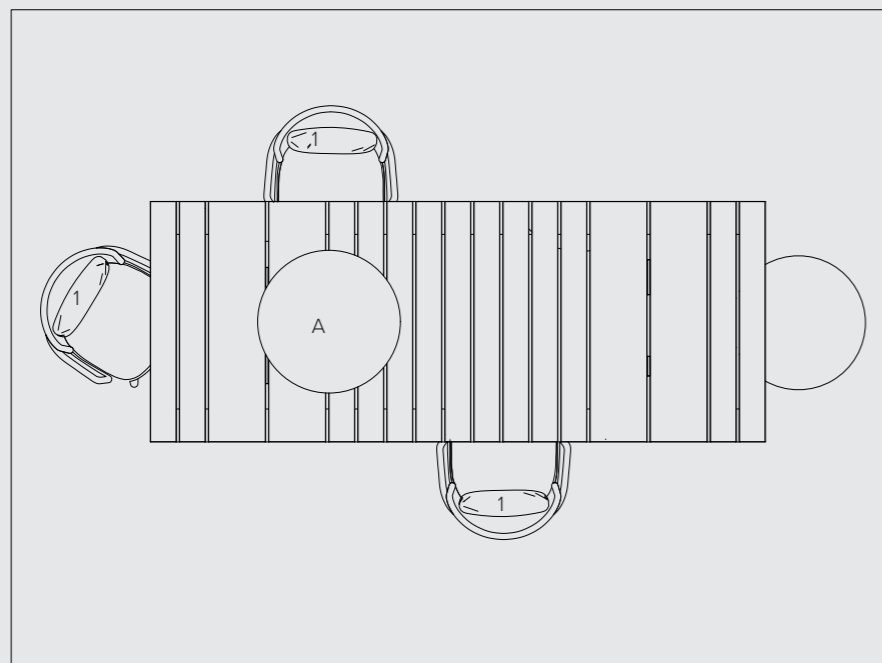

ITEM	ART.NR.	QTY	DESCRIPTION	FINISH
seat 1	C02718S-F20W	4	Suro - armchair CU	Naram Almond
seat 2	C05032-E25W	1	Nomad - pouf S	Gaelic Sandstone
Deco 1	C0001-F20	4	Deco 40x40 cm	Naram Almond

CUSHIONS / STYLING



Naram almond



Gaelic Sandstone

ITEM	DESCRIPTION
A	Beghard bowl - Brass - Michaël Verheyden



© Michaël Verheyden

No part of this publication can be reproduced by any means, also electronically, without specific authorization from Tribù nv.

Tribù reserves the right to modify their products without prior notification. Colours may differ from reality. Our designs are registered internationally.

ELMINA Bratislava
OC Lightpark, prízemie
Raciaska 90
831 02 Bratislava
e: elmina@elmina.sk
w: **www.elmina.sk**
t: +420 910 919 711

TRIBÙ

01/10/2024 - 30/09/2025

ELMINA[®]

môj životný štýl

ELMINA Bratislava
OC Lightpark
Račianska 90, Bratislava
tel.: 02/634 522 59
elmina@elmina.sk
www.elmina.sk

Ceny vr. DPH

INDEX

L'INDEX - INHOUDSTABEL

	AMANU	8		UMBRELLAS	102
	BRANCH	12		LOW TABLES	
NEW	CESTA	14		ALUMINIUM	103
	CTR	16	NEW	MARE	104
	ELIO	20	NEW	SEREN	105
NEW	ELIO SOFA	22	UPDATED	TEAK	106
	ELIO SOFA SETS	25		ACCESSORIES	108
	FORUM	27		LOFT RUGS	109
UPDATED	ILLUM	28		SHINDI RUGS	109
	KOS	32		MONSIEUR TRICOT HANGING	110
NEW	LUCCA	34		MONSIEUR TRICOT STANDING	111
	MOOD	36	NEW	MONSIEUR TRICOT STANDING WIRED	112
UPDATED	NATAL ALU SOFA REGULAR	42		POUFS	
	NATAL ALU SOFA DEEP	43		POUFS	114
	NATAL ALU SOFA MERIDIENNE	44		NOMAD POUFS	114
	NATAL ALU SOFA SETS	45		MAI POUFS	114
	NATAL ALU X TABLE	48		DECO CUSHIONS	115
	NODI	49		MAINTENANCE PRODUCTS	116
	NODI SOFA REGULAR	50		LOW TABLES OVERVIEW	118
	NODI SOFA DEEP	51		DINING TABLES - BY SIZE	120
	NODI SOFA LOUNGE	52		DINING TABLES - BY MATERIALS	122
	NODI SOFA MERIDIENNE	53		COVERS FOR SOFA'S	123
	NODI SOFA SETS	54		COVERS FOR DINING TABLES	124
	NOMAD	58		COVERS FOR LOW DINING TABLES	125
	NOX	59		COVERS FOR LOW TABLES	127
UPDATED	OTTO	60			
	PAVILION DAYBED	62			
	PURE	65			
	PURE SOFA	67			
	PURE SETS	68			
	SENJA	70			
	SENJA SOFA REGULAR	72			
NEW	SENJA SOFA DEEP	74			
	SENJA SOFA ORGANIC CORNER	76			
	SENJA SOFA MERIDIENNE	77			
	SENJA SOFA SETS	78			
	SURO	82			
	T-TABLE DINING	84			
	T-TABLE LOW DINING	85			
	T-TABLE LOW DINING	86			
	T-TABLE COFFEE	87			
	TAO	88			
	TOSCA	89			
	UKIYO	94			
	VIS À VIS SOFA	97			
	VIS À VIS SOFA SETS	99			

TECHNICAL STANDARDS - NORMES TECHNIQUES 130
 TECHNISCHE NORMEN

CUSHIONS - COUSSINS - KUSSENS

PRICING CUSHIONS	136
FIRE RETARDANT CUSHIONS	137
COLORS	138
FILLINGS	151
FABRIC TYPES	154
SOLUTION DYED ACRYLICS	155
SOLUTION DYED POLYOLEFIN	156
PVC COATED POLYESTER	157
FABRIC PROPERTIES	158
LEGEND FABRIC PROPERTIES	165

MATERIALS - MATÉRIAUX - MATERIALEN

ALUMINIUM	168
BATYLINE®	169
BRASS METAL	170
CANAX®	171
CERAMIC	173
NEW MASS-COLOURED GLASS	174
GLAZED LAVA STONE	175
GRANITE	176
LIGHTENED CONCRETE	177
MONSIEUR TRICOT	180
OUTDOOR RUGS	183
POWDERCOATED STAINLESS STEEL	184
RECYCLED ACRYLIC	185
SYNTHETICS	186
TEXTILENE STRAPS	190
TOSCA WEAVE	191
TRAVERTINE	192
TRICORD®	193
VILEX WEAVE	195
TRIZO WEAVE	196

MAINTENANCE - ENTRETIEN - ONDERHOUD

CLEANING	200
PROTECTING	201
PRODUCTS	202

6 LEGEND

LÉGENDE – LEGENDE

 Stackable
Empilable
Stapelbaar

 To assemble
A monter
Te monteren



Right arm
Bras droit
Rechter arm



Left arm
Bras gauche
Linker arm

 Lounger with wheels
Chaise lounge avec des roues
Lounger met wielen

General Information

Dimensions and technical details may be subject to changes without prior notice. Tribù cannot be held responsible for any possible printing errors.

The reproduction of colors may differ from reality.

In the case of the shade of wengé, the designation refers exclusively to the shade and not to the material.

When ordering a sofa configuration that is not shown in the price list, please include a sketch with your order.

Les dimensions et les détails techniques peuvent être sujets à des modifications sans préavis. Tribù n'est pas responsable pour des erreurs d'impression éventuelles.

La représentation des couleurs peut varier de la réalité.

Dans le cas de la teinte wengé, l'appellation se réfère exclusivement à la teinte et non à la matière.

Lors de la commande d'une configuration de canapé qui ne figure pas dans la liste de prix, veuillez envoyer un dessin avec votre commande.

Afmetingen en technische afwerking kunnen gewijzigd worden zonder voorafgaand bericht. Tribù kan niet verantwoordelijk gesteld worden voor eventuele drukfouten.

De weergave van kleuren kan verschillen met de werkelijkheid.

Bij de tint wengé verwijst de aanduiding uitsluitend naar de tint en niet naar het materiaal.

Bij bestelling van een sofaconfiguratie die niet in de prijslijst is weergegeven, gelieve een schets mee te sturen met uw bestelling.

WARRANTY

GARANTIE – GARANTIE

Terms of warranty

A warranty period of 3 years applies to all Tribù branded furniture items and 1 year for cushions, fabrics and protective covers, against all manufacturing and material errors that would affect their use. The warranty commences on the day the product was bought from an official Tribù trading partner (see date on the proof of purchase).

The warranty applies to manufacturing and material errors that occur during normal usage, and not to errors or deficiencies occurring in the course of time or normal usage (wear and tear). Conditions that are not covered by this warranty include – but are not restricted to – colours fading, changes in wood textures, scratches occurring during use, damage resulting from defective maintenance or incorrect use, etc. The warranty does not for example cover discolouration or colours running, cracks, scratches or tears occurring in the varnish due to usage.

Conditions de garantie

Pour tous les produits de marque Tribù, une période de garantie de 3 ans (1 an pour des coussins, des tissus et des housses de protection) s'applique pour les erreurs de fabrication ou de matériaux qui affecteraient leur usage. La garantie commence le jour où le produit est acheté chez un partenaire commercial officiel de Tribù (cfr date de la preuve d'achat).

La garantie s'applique sur les erreurs de matériaux et de production qui surviennent en cas d'usage normal et non pas d'erreurs ou d'imperfections dues au passage du temps ou à un usage normal (usure). Les éléments non couverts par cette garantie comprennent – mais sans s'y limiter – l'effacement des couleurs, les modifications au niveau des textures du bois, les griffures liées à l'usage, les dégâts causés par un entretien inapproprié ou une mauvaise utilisation, etc. Par exemple, la garantie ne couvre pas la dégradation ou l'effacement des couleurs, les craquelures, les griffures ou les fissures dans le vernis causés par un usage normal.

Garantievoorwaarden

Voor alle Tribù merkproducten geldt een garantieperiode van 3 jaar (1 jaar voor kussens, stoffen en beschermhoezen) tegen fabrieks- of materiaalfouten die het gebruik ervan zouden beïnvloeden. De garantie begint op de dag dat het product bij een officiële handelspartner van Tribù is aangekocht (cfr datum aankoopbewijs).

De garantie is van toepassing op materiaal- en productiefouten die bij normaal gebruik zijn ontstaan, niet op fouten of onvolkomenheden als gevolg van het verstrijken van de tijd of normaal gebruik (slijtage). Omstandigheden die niet gedekt zijn door deze garantie omvatten - maar zijn niet gelimiteerd tot – vervagen van kleuren, veranderingen in houttexturen, krassen ontstaan door gebruik, schade ten gevolge van gebrekkig onderhoud of verkeerd gebruik, enz. De garantie dekt bijvoorbeeld geen verkleuring of uitlopen van kleuren, barsten, krassen of scheurtjes in lak die ontstaan zijn door gebruik.



Plantation teak from Java
Teck de plantation de Java
Plantageteak uit Java

Canax®
Canax®
Canax®

Armchair
Fauteuil repas
Armstoel

02618-10

€ 1.695



D2618
Cover
Housse
Hoes
€ 200

C02618SW
Seat cushion
Coussin d'assise
Zitkussen

D € 220
E € 290
F € 335

C02618W

Seat & back cushion
Coussin d'assise et de dossier
Zit-en rugkussen

D € 445
E € 595
F € 695



Lounge chair
Fauteuil lounge
Lage stoel

02612-10

€ 2.295



D2612
Cover
Housse
Hoes
€ 260

C02612W
Seat & back cushion
Coussin d'assise et de dossier
Zit-en rugkussen

D € 710
E € 825
F € 935



Plantation teak from Java
Teck de plantation de Java
Plantageteak uit Java

Canax®
Canax®
Canax®

NEW

3-Seater sofa
Canapé 3 places
Sofa 3-zit

02609-10

€ 4.990



D26090

Cover
Housse
Hoes
€ 490

C02609BSETW

Back cushion Set casual D € 970
Set de coussin dossier casual E € 1.170
Rugkussen set casual F € 1.360

C02609SW

Seat cushion D € 2.640
Coussin d'assise E € 2.920
Zitkussen F € 3.185



NEW

Daybed
Daybed
Daybed

02649-10

€ 4.480



D26490

Cover
Housse
Hoes
€ 400

C02649W

Seat & back cushion D € 2.285
Coussin d'assise et de dossier E € 2.665
Zit-en rugkussen F € 3.035



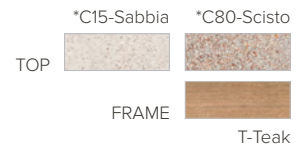

Plantation teak from Java
Teck de plantation de Java
Plantageteak uit Java

Table top: ceramic
Dessus de table: céramique
Tafelblad: keramiek

*This colour may possibly show veins
*Des veines peuvent éventuellement figurer sur cette couleur
*Deze kleur kan mogelijk anders vertonen

NEW / Low table dia 90
Table basse dia 90
Lage Tafel dia 90

€ 2.750

02684L-Cx

02684M-Cx

02684H-Cx



NEW / Low table dia 125
Table basse dia 125
Lage Tafel dia 125

€ 3.850

02686L-Cx

02686M-Cx

02686H-Cx



NEW / Low table rectangular 155x58cm
Table basse 155x58cm
Lage Tafel rechthoekig 155x58cm

€ 3.200

02688L-Cx

02688M-Cx

02688H-Cx



/ Dining table 290 cm
Table à manger 290 cm
Eettafel 290 cm

€ 13.900

02652-C15

02652-C80

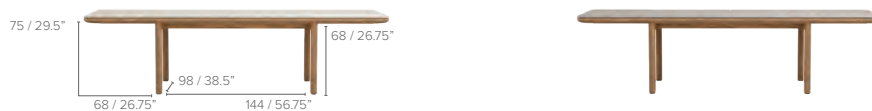

/ Dining table 350 cm
Table à manger 350 cm
Eettafel 350 cm

€ 16.950

02654-C15

02654-C80

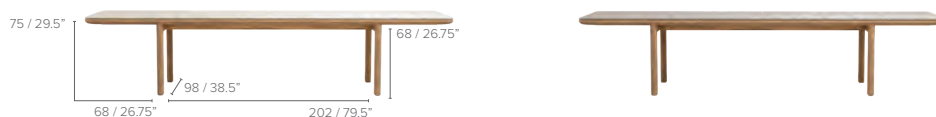

Covers for tables see p.124-127
Des housses pour les tables voir p.124-127
Hoezen voor tafels zie p.124-127



Plantation teak from Java
Teck de plantation de Java
Plantageteak uit Java

NEW

C-table
Table-C
C-tafel

02685



€ 1.150 Teak

D2685

Cover
Housse
Hoes

€ 155

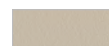

Aluminium, high pressure injected
Aluminium, moulé sous pression
Spuitgegoten aluminium

Polypropylene reinforced with glassfiber
Polypropylène renforcé avec de la fibre de verre
Polypropyleen versterkt met glasvezel

Batyline
Batyline
Batyline

3
Side chair
Chaise
Stoel

€ 650

07610-00-00

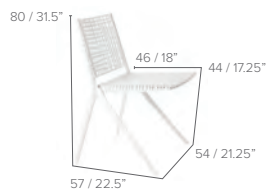

07610-10-10



07610-89-89



D7610
Cover
Housse
Hoes
€ 200

C07610SW
Seat cushion
Coussin d'assise
Zitkussen
D € 140
E € 175
F € 185



2
Armchair
Fauteuil repas
Armstoel

€ 765

07618-00-00

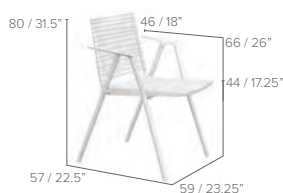

07618-10-10



07618-89-89



D7618
Cover
Housse
Hoes
€ 230

C07610SW
Seat cushion
Coussin d'assise
Zitkussen
D € 140
E € 175
F € 185



12
Adjustable lounger Batyline
Chaise longue réglable Batyline
Ligbed, verstelbaar Batyline

€ 2.095

07640-00-00

07640-10-71**
** 71 Silkgrey

07640-89-89



D7640
Cover
Housse
Hoes
€ 275

C07640W
Cushion
Coussin
Kussen
D € 860
E € 1.080
F € 1.325



	T-Teak	00-White	10-Linen	89-Wengé
TOP				
		00-White	10-Linen	89-Wengé
FRAME				

Aluminium, high pressure injected
Aluminium, moulé sous pression
Spuitgegoten aluminium

Plantation teak from Java
Teck de plantation de Java
Plantageteak uit Java

Table top: aluminium or teak
Dessus de table: aluminium ou teck
Tafelblad: aluminium of teak

Bistro table round
Table bistro ronde
Bistro tafel rond

75 / 29.5"
72 / 28.25"



€ 1.420

dia 80cm

07660-00-00

07660-10-10

07660-89-89

€ 2.890

dia 125cm

07662-00-00

07662-10-10

07662-89-89

€ 1.180

dia 80cm

07660-00-T

07660-10-T

07660-89-T

€ 2.495

dia 125cm

07662-00-T

07662-10-T

07662-89-T

Bistro table square
Table bistro carrée
Bistro tafel vierkant

75 / 29.5"
72 / 28.25"



€ 1.565

80x80cm

07671-00-00

07671-10-10

07671-89-89

€ 1.770

90x90cm

07670-00-00

07670-10-10

07670-89-89

€ 1.425

80x80cm

07671-00-T

07671-10-T

07671-89-T

€ 1.770

90x90cm

07670-00-T

07670-10-T

07670-89-T

Dining table
Table à manger
Eettafel

75 / 29.5"
72 / 28.25"



€ 3.490

210x98cm

07652-00-00

07652-10-10

07652-89-89

€ 5.565

300x110cm

07654-00-00

07654-10-10

07654-89-89

€ 4.335

210x98cm

07652-00-T

07652-10-T

07652-89-T

€ 6.250

300x110cm

07654-00-T

07654-10-T

07654-89-T

Aluminium, high pressure injected
 Aluminium, moulé sous pression
 Smitgegoten aluminium

Canax®
 Canax®
 Canax®

The Cesta chair rotates 360 degrees

Lounge chair, 360° swivel
 Fauteuil lounge, 360° pivotant
 Lage stoel, 360° draaibaar

07712-10-10

€ 2.150



D7712

Cover
 Housse
 Hoes
€ 255

C07712W

Seat & back cushion D **€ 925**
 Coussin d'assise et de dossier E **€ 1.055**
 Zit-en rugkussen F **€ 1.185**



WEAVE

FRAME

10-Linen 89-Wengé

00-White 10-Linen 89-Wengé

Powdercoated stainless steel
Inox laqué par poudrage
Gepoedercoat inox

Plaited Tricord (Polyolefin)
Tricord tressé (Polyoléfine)
Geweven Tricord (Polyolefine)

Armchair
Fauteuil repas
Armstoel

€ 1.395



D1118
Cover
Housse
Hoes
€ 180

C01118SW
Seat cushion
Coussin d'assise
Zitkussen
D € 195
E € 255
F € 295



Bar chair
Tabouret de bar
Barstoel

€ 1.795



D1116
Cover
Housse
Hoes
€ 275

C01116SW
Seat cushion
Coussin d'assise
Zitkussen
D € 195
E € 255
F € 295



Powdercoated stainless steel
 Inox laqué par poudrage
 Gepoedercoat inox

Plaited Tricord (Polyolefin)
 Tricord tressé (Polyoléfine)
 Geweven Tricord (Polyolefine)



Lounge chair
 Fauteuil Lounge
 Lage stoel

€ 2.495



01102-00-10



01102-10-10



01102-89-10



01102-10-89



01102-89-89

D1102
 Cover
 Housse
 Hoes
€ 230

C01100BCAW
 Back cushion casual
 Coussin dossier casual
 Casual rugkussen
 D **€ 310**
 E **€ 340**
 F **€ 390**

C01102SW
 Seat cushion
 Coussin d'assise
 Zitkussen
 D **€ 385**
 E **€ 435**
 F **€ 490**



2-Seater sofa
 Canapé 2 places
 Sofa 2-zit

€ 4.295



01108-00-10



01108-10-10



01108-89-10



01108-10-89



01108-89-89

D1108
 Cover
 Housse
 Hoes
€ 305

C01100BCAW
 Back cushion Casual
 Coussin dossier Casual
 Casual rugkussen
 Order 2x!
 D **€ 310**
 E **€ 340**
 F **€ 390**

C01108SW
 Seat cushion
 Coussin d'assise
 Zitkussen
 D **€ 1.050**
 E **€ 1.190**
 F **€ 1.325**



		10-Linen	89-Wengé
	WEAVE		
FRAME			
	00-White	10-Linen	89-Wengé

Powdercoated stainless steel
Inox laqué par poudrage
Gepoedercoat inox

Plaited Tricord (Polyolefin)
Tricord tressé (Polyoléfine)
Geweven Tricord (Polyolefine)

Meridienne right
Mériidienne droite
Rechter meridienne

01104-00-10



€ 6.550

01104-10-10



01104-89-10



01104-10-89



01104-89-89



D1104
Cover
Housse
Hoes
€ 405

C01100BCAW
Back cushion Casual D € 310
Coussin dossier Casual E € 340
Casual rugkussen F € 390

C01104SW
Seat cushion D € 1.455
Coussin d'assise E € 1.545
Zitkussen F € 1.670



Meridienne left
Mériidienne gauche
Linker meridienne

01103-00-10



€ 6.550

01103-10-10



01103-89-10



01103-10-89



01103-89-89



D1103
Cover
Housse
Hoes
€ 405

C01100BCAW
Back cushion Casual D € 310
Coussin dossier Casual E € 340
Casual rugkussen F € 390

C01103SW
Seat cushion D € 1.455
Coussin d'assise E € 1.545
Zitkussen F € 1.670



Plantation teak from Java
Teck de plantation de Java
Plantageteak uit Java

Plaited Tricord (polyolefin)
Tricord tressé (polyoléfine)
Geweven Tricord (polyolefine)

Armchair
Fauteuil repas
Stoel

€ 1.295

02518-10



02518-89



D2518
Cover
Housse
Hoes
€ 180

C02518SW
Seat cushion
Coussin d'assise
Zitkussen
D € 170
E € 210
F € 240



Lounge chair
Fauteuil
Lage Stoel

€ 2.100

02512-10



02512-89



D2512
Cover
Housse
Hoes
€ 215

C02512SW
Seat cushion
Coussin d'assise
Zitkussen
D € 365
E € 390
F € 420



Plantation teak from Java
Teck de plantation de Java
Plantageteak uit Java

Plaited Tricord (polyolefin)
Tricord tressé (polyoléfine)
Geweven Tricord (polyolefine)

Lounge Chair High Back
Fauteuil à dossier haut
Lage Stoel met hoge rug

€ 2.750



D2520
Cover
Housse
Hoes
€ 230

C02520W
Cushion
Coussin
Kussen
D € 1.150
E € 1.275
F € 1.395

C02521BW
Back cushion
Coussin dossier
Rugkussen
D € 440
E € 465
F € 500

C02521SW
Seat cushion
Coussin d'assise
Zitkussen
D € 310
E € 340
F € 390



Footrest
Repose-pieds
Voetenbankje

€ 995



D2590
Cover
Housse
Hoes
€ 175

C02590W
Seat cushion
Coussin d'assise
Zitkussen
D € 270
E € 290
F € 315





Plantation teak from Java
Teck de plantation de Java
Plantageteak uit Java

Plaited Tricord (polyolefin)
Tricord tressé (polyoléfine)
Geweven Tricord (polyolefine)

NEW! 1-Seater module

Full backrest
0350200-10

€ 3.295



D350200
Cover
Housse
Hoes
€ 290

C03500BW
Back cushion
Coussin dossier
Rugkussen
D € 455
E € 525
F € 590

C03502SW
Seat cushion
Coussin d'assise
Zitkussen
D € 1.600
E € 1.775
F € 1.960



NEW! Poufs

1-Seater pouf
03502

€ 2.495



D3502
Cover
Housse
Hoes
€ 240

C03502SW
Seat cushion
Coussin d'assise
Zitkussen
D € 1.600
E € 1.775
F € 1.960



2-Seater pouf
03508

€ 3.495



D3508
Cover
Housse
Hoes
€ 240

C03508SW
Seat cushion
Coussin d'assise
Zitkussen
D € 2.340
E € 2.600
F € 2.875



3-Seater pouf
03509

€ 5.495



D3509
Cover
Housse
Hoes
€ 530

C03509SW
Seat cushion
Coussin d'assise
Zitkussen
D € 3.240
E € 3.580
F € 3.955



Daybed pouf
03549

€ 5.625



D3549
Cover
Housse
Hoes
€ 550

C03549SW
Seat cushion
Coussin d'assise
Zitkussen
D € 3.325
E € 3.715
F € 4.160



Plantation teak from Java
Teck de plantation de Java
Plantageteak uit Java

Plaited Tricord (polyolefin)
Tricord tressé (polyoléfine)
Geweven Tricord (polyolefine)

NEW 2-Seater modules

Full backrest
0350800-10

€ 4.765



C03500BW

Back cushion D € 455
Coussin dossier E € 525
Rugkussen F € 590
(order 2x!)

C03508SW

Seat cushion D € 2.340
Coussin d'assise E € 2.600
Zitkussen F € 2.875

Cover **D350800** € 450



Meridienne left
0350803-10

€ 4.295



C03500BW

Back cushion D € 455
Coussin dossier E € 525
Rugkussen F € 590
(order 2x!)

C03508SW

Seat cushion D € 2.340
Coussin d'assise E € 2.600
Zitkussen F € 2.875

Cover **D350803** € 450



Meridienne right
0350804-10

€ 4.295



C03500BW

Back cushion D € 455
Coussin dossier E € 525
Rugkussen F € 590
(order 2x!)

C03508SW

Seat cushion D € 2.340
Coussin d'assise E € 2.600
Zitkussen F € 2.875

Cover **D350804** € 450



Extension
0350828-10

€ 4.095



C03500BW

Back cushion D € 455
Coussin dossier E € 525
Rugkussen F € 590
(order 2x!)

C03508SW

Seat cushion D € 2.340
Coussin d'assise E € 2.600
Zitkussen F € 2.875

Cover **D350828** € 450



NEW 3-Seater modules

Full backrest
0350900-10

€ 6.795



C03500BW

Back cushion D € 455
Coussin dossier E € 525
Rugkussen F € 590
(order 3x!)

C03509SW

Seat cushion D € 3.240
Coussin d'assise E € 3.580
Zitkussen F € 3.955

Cover **D350900** € 595



Meridienne left
0350903-10

€ 6.335



C03500BW

Back cushion D € 455
Coussin dossier E € 525
Rugkussen F € 590
(order 3x!)

C03509SW

Seat cushion D € 3.240
Coussin d'assise E € 3.580
Zitkussen F € 3.955

Cover **D350903** € 595



Meridienne right
0350904-10

€ 6.335



C03500BW

Back cushion D € 455
Coussin dossier E € 525
Rugkussen F € 590
(order 3x!)

C03509SW

Seat cushion D € 3.240
Coussin d'assise E € 3.580
Zitkussen F € 3.955

Cover **D350904** € 595





Plantation teak from Java
Teck de plantation de Java
Plantageteak uit Java

Plaited Tricord (polyolefin)
Tricord tressé (polyoléfine)
Geweven Tricord (polyolefine)

NEW

Daybed modules

Full backrest
0354900-10

€ 6.895



Meridienne left
0354903-10

€ 6.425



Meridienne right
0354904-10

€ 6.425



Extension
0354928-10

€ 6.225

**C03500BW**

Back cushion D € 455
Coussin dossier E € 525
Rugkussen F € 590
(order 2x!)

C03500BW

Back cushion D € 455
Coussin dossier E € 525
Rugkussen F € 590
(order 2x!)

C03500BW

Back cushion D € 455
Coussin dossier E € 525
Rugkussen F € 590
(order 2x!)

C03500BW

Back cushion D € 455
Coussin dossier E € 525
Rugkussen F € 590
(order 2x!)

C03549SW

Seat cushion D € 3.325
Coussin d'assise E € 3.715
Zitkussen F € 4.160

C03549SW

Seat cushion D € 3.325
Coussin d'assise E € 3.715
Zitkussen F € 4.160

C03549SW

Seat cushion D € 3.325
Coussin d'assise E € 3.715
Zitkussen F € 4.160

C03549SW

Seat cushion D € 3.325
Coussin d'assise E € 3.715
Zitkussen F € 4.160

Cover

D354900 € 620

D354903 € 620

D354904 € 620

D354928 € 620



Combination examples
Exemples de combinaisons
Combinatievoorbeelden

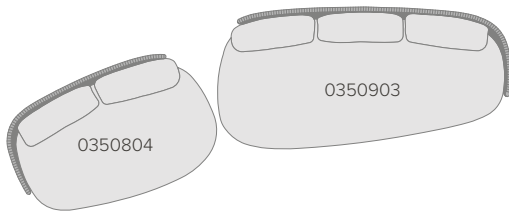

SET 1

Frame: 0350804 + 0350903
Cushions: 5x C03500BW + C03508SW + C03509SW
Covers: D350804 + D350903

Total price without covers: Cat.D € 18.485 E € 19.435 F € 20.410

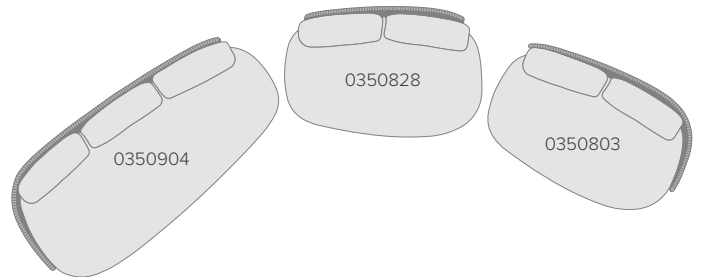

SET 2

Frame: 0350904 + 0350828 + 0350803
Cushions: 7x C03500BW + C03509SW + 2x C03508SW
Covers: D350904 + D0350828 + D350803

Total price without covers: Cat.D € 25.830 E € 27.180 F € 28.560

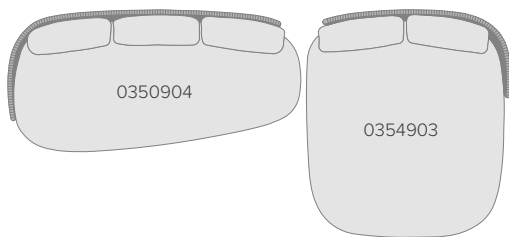

SET 3

Frame: 0350904 + 0354903
Cushions: 5x C03500BW + C03509SW + C03549SW
Covers: D350904 + D354903

Total price without covers: Cat.D € 21.600 E € 22.680 F € 23.825

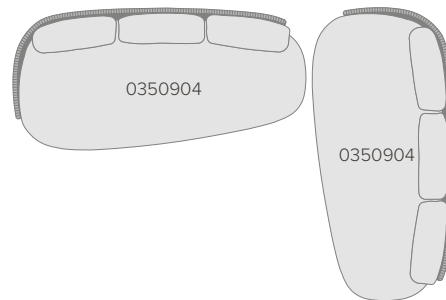

SET 4

Frame: 2x 0350904
Cushions: 6x C03500BW + 2x C03509SW
Covers: 2x D350904

Total price without covers: Cat.D € 21.880 E € 22.980 F € 24.120

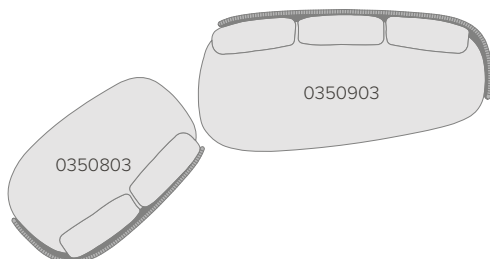

SET 5

Frame: 0350803 + 0350903
Cushions: 5x C03500BW + C03508SW + C03509SW
Covers: D350803 + D350903

Total price without covers: Cat.D € 18.485 E € 19.435 F € 20.410

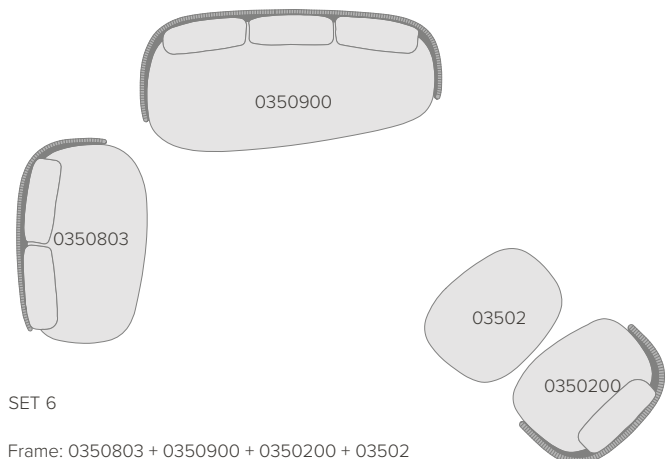

SET 6

Frame: 0350803 + 0350900 + 0350200 + 03502
Cushions: 6x C03500BW + C03508SW + C03509SW + 2x C03502SW
Covers: D350903 + D350900 + D350200 + D3502

Total price without covers: Cat.D € 28.390 E € 29.760 F € 31.170

Powdercoated aluminium
Aluminium peint par poudrage
Gepoedercoat aluminium

Batyline
Batyline
Batyline

* 71-Canatex silkgrey
* 71-Canatex silkgrey
* 71-Canatex silkgrey

Adjustable lounger
Chaise longue réglable
Ligbed, verstelbaar

€ 1.295

06040-10-71S*



06040-89-89S



D6140
Cover
Housse
Hoes
€ 255

C06040W
Cushion
Coussin
Kussen

D € 550
E € 725
F € 930



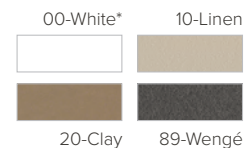

Aluminium, high pressure injected
Aluminium, moulé sous pression
Spuitgegoten aluminium

Batyliné
Batyliné
Batyliné

* Only for Armchair
* Seulement pour le fauteuil
* Alleen voor Armchair

³ Armchair
Fauteuil repas
Armstoel

€ 675



06518-10



06518-20



06518-89



D6518

Cover
Housse
Hoes
€ 175

C06518SW

Seat cushion
Coussin d'assise
Zitkussen

D € 150
E € 175
F € 195

C06518W

Seat & back cushion
Coussin d'assise et de dossier
Zit-en rugkussen

D € 330
E € 415
F € 525



NEW ³ Lounge chair
Fauteuil lounge
Lage Stoel

€ 1.095



06512-10



06512-89



D6512

Cover
Housse
Hoes
€ 240

C06512BW

Back cushion
Coussin dossier
Rugkussen

D € 165
E € 205
F € 250

C06512SW

Seat cushion
Coussin d'assise
Zitkussen

D € 240
E € 310
F € 380



Aluminium, high pressure injected
Aluminium, moulé sous pression
Spuitgegoten aluminium

Batyline
Batyline
Batyline

Plantation teak from Java
Teck de plantation de Java
Plantageteak uit Java

 Bench, teak seat
Banc, siège en teck
Bank, zit in teak

€ 1.990

06534-00



06534-10



06534-89



D6534
Cover
Housse
Hoes
€ 245

C07434W

Cushion* D € 120
Coussin* E € 150
Kussen* F € 180
*42 x 42 cm, order 4x!



 Adjustable lounger
Chaise longue réglable
Ligbed, verstelbaar

€ 2.800

06540-00

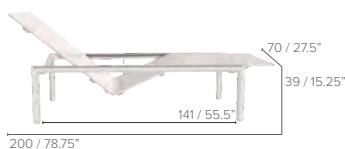

06540-10



06540-89



D6540
Cover
Housse
Hoes
€ 355

C06540W

Cushion D € 665
Coussin E € 780
Kussen F € 1.035



	10-Linen	*C15-Sabbia	89-Piombo	T-Teak
TOP				
FRAME				
	**00-White	10-Linen	89-Wengé	**T-Teak

Aluminium, high pressure injected
Aluminium, moulé sous pression
Spuitgegoten aluminium

Plantation teak from Java
Teck de plantation de Java
Plantageteak uit Java

**Not for counter height table
**Pas pour la table hauteur de comptoir
**Niet voor tafel aanrethoogte

*This colour may possibly show veins
*Des veines peuvent éventuellement figurer sur cette couleur
*Deze kleur kan mogelijk anders vertonen



Dining table
Table à manger
Eettafel

€ 1.960	100x100cm	06573-00-x	06573-10-x	06573-89-x
€ 2.880	152x100cm	06550-00-x	06550-10-x	06550-89-x
€ 3.580	212x100cm	06552-00-x	06552-10-x	06552-89-x
€ 5.190	267x100cm	06554-00-x	06554-10-x	06554-89-x
€ 1.960	100x100cm	06573-00-T	06573-10-T	06573-89-T
€ 2.880	152x100cm	06550-00-T	06550-10-T	06550-89-T
€ 4.750	212x100cm	06552-00-T	06552-10-T	06552-89-T
€ 5.990	267x100cm	06554-00-T	06554-10-T	06554-89-T
€ 3.280	212x71cm	06552xs-00-x	06552xs-10-x	06552xs-89-x
€ 5.190	267x71cm	06554xs-00-x	06554xs-10-x	06554xs-89-x
€ 3.990	212x71cm	06552xs-00-T	06552xs-10-T	06552xs-89-T
€ 4.990	267x71cm	06554xs-00-T	06554xs-10-T	06554xs-89-T



Dining table teak
Table à manger teck
Eettafel teak

€ 2.810	100x100cm	06573-T-x
€ 3.935	152x100cm	06550-T-x
€ 4.895	212x100cm	06552-T-x
€ 6.350	267x100cm	06554-T-x
€ 2.810	100x100cm	06573-T-T
€ 3.935	152x100cm	06550-T-T
€ 6.065	212x100cm	06552-T-T
€ 7.150	267x100cm	06554-T-T
€ 5.190	212x73cm	06552XS-T-x
€ 5.900	212x73cm	06552XS-T-T

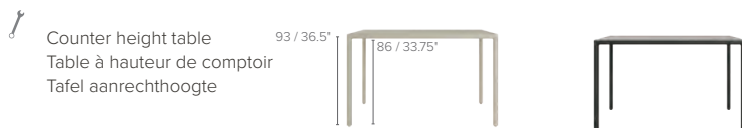

Counter height table
Table à hauteur de comptoir
Tafel aanrethoogte

€ 2.930	152x100cm	06560-10-xx	06560-89-xx
€ 3.330	212x71cm	06564XS-10-xx	06564XS-89-xx
€ 2.930	152x100cm	06560-10-T	06560-89-T
€ 4.040	212x71cm	06564XS-10-T	06564XS-89-T

Note: the height and clearance under the table may differ according to the type of table top. Please consult the product sheet on our website.

Remarque: la hauteur et le dégagement sous la table peuvent différer selon le type de dessus de table. Pour plus de détails, consultez la fiche produit sur notre site internet.

Opmerking: afhankelijk van het type tafelblad kunnen de hoogte en de vrije ruimte onder de tafel verschillen. Details vindt u op de productfiche op onze website.

Covers for tables see p.124-127
Des housses pour les tables voir p.124-127
Hoezen voor tafels zie p.124-127

Plantation teak from Java
Teck de plantation de Java
Plantageteak uit Java

* Cushion with overstitched pattern
* Modèle coussin avec coutures sellier
* Kussen met doorstikt patroon

³ Armchair
Fauteuil repas
Armstoel

€ 1.195

04018



D4018
Cover
Housse
Hoes
€ 200

C04018SW

Seat cushion* D € 175
Coussin d'assise* E € 220
Zitkussen* F € 270



³ Lounge Chair
Fauteuil
Lage stoel

€ 1.395

04012



D6038
Cover
Housse
Hoes
€ 135

C04012SW

Seat cushion* D € 195
Coussin d'assise* E € 300
Zitkussen* F € 355



Bar chair
Tabouret de bar
Barstoel

€ 995

04016



D4016
Cover
Housse
Hoes
€ 200

C04016SW

Seat cushion* D € 170
Coussin d'assise* E € 200
Zitkussen* F € 225

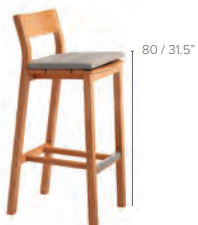

Plantation teak from Java
Teck de plantation de Java
Plantageteak uit Java

⊖ Lounger, adjustable
Chaise longue réglable
Ligbed, verstelbaar

04040

€ 2.450

**D6037**

Cover
Housse
Hoes
€ 185

C04040W

Cushion* D € 735
Coussin* E € 890
Kussen* F € 1.140



⌘ Dining Table
Table à manger
Eettafel



€ 2.765 98x98cm
€ 4.355 224x100cm
€ 5.670 266x100cm
€ 7.930 308x110cm

04073

04052
04053
04054

NEW

FRAME

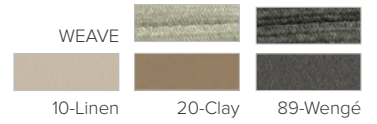

Aluminium, high pressure injected
Aluminium, moulé sous pression
Sputgegoten aluminium

Batyline
Batyline
Batyline

Tricord Waves
Tricord Waves
Tricord Waves

Armchair
Fauteuil repas
Armstoel

03218-10-10

03218-20-10

03218-89-89

€ 890

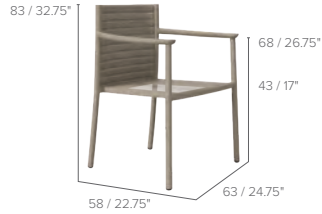
**D3218**

Cover
Housse
Hoes
€ 195

C03218BW

Back cushion
Coussin dossier
Rugkussen

D € 145
E € 165
F € 210

C03218SW

Seat cushion
Coussin d'assise
Zitkussen

D € 155
E € 195
F € 230



Lounge Chair
Fauteuil lounge
Lage stoel

03212-10-10

03212-20-10

03212-89-89

€ 1.745

**D3212**

Cover
Housse
Hoes
€ 240

C03212BW

Back cushion
Coussin dossier
Rugkussen

D € 285
E € 355
F € 420

C03212SW

Seat cushion
Coussin d'assise
Zitkussen

D € 390
E € 550
F € 705



	*C11-Sienna	*C76-Pebble	*C86-Pompei	35
TOP				
FRAME	10-Linen	20-Clay	89-Wengé	

Aluminium, high pressure injected
Aluminium, moulé sous pression
Spuitgegoten aluminium

*This colour may possibly show veins
*Des veines peuvent éventuellement figurer sur cette couleur
*Deze kleur kan mogelijk anders vertonen

Dining Table 240x110cm
Table à manger
Eettafel

€ 5.550



Dining Table 320x125cm
Table à manger
Eettafel

€ 6.800



Plantation teak from Java
Teck de plantation de Java
Plantageteak uit Java

Plaited Tricord (polyolefin)
Tricord tressé (polyoléfine)
Geweven Tricord (polyolefine)

Armchair
Fauteuil repas
Armstoel

€ 1.095



06218-85

D6082

Cover
Housse
Hoes
€ 180

C06218BW

Lumbar cushion
Coussin lombaire
Lendenkussen
D € 95
E € 115
F € 135

C06218SW

Seat cushion
Coussin d'assise
Zitkussen
D € 120
E € 155
F € 180



C06218BHW

High back cushion
Coussin dossier haut
Hoog rugkussen
D € 135
E € 170
F € 190

C06218SW

Seat cushion
Coussin d'assise
Zitkussen
D € 120
E € 155
F € 180



C06218BCAW

Back cushion Casual
Coussin dossier Casual
Casual rugkussen
D € 160
E € 190
F € 220

C06218SW

Seat cushion
Coussin d'assise
Zitkussen
D € 120
E € 155
F € 180



Bar chair
Tabouret de bar
Barstoel

€ 1.360



06216-85

D6088

Cover
Housse
Hoes
€ 195

C06218BW

Lumbar cushion
Coussin lombaire
Lendenkussen
D € 95
E € 115
F € 135

C06218SW

Seat cushion
Coussin d'assise
Zitkussen
D € 120
E € 155
F € 180



C06218BHW

High back cushion
Coussin dossier haut
Hoog rugkussen
D € 135
E € 170
F € 190

C06218SW

Seat cushion
Coussin d'assise
Zitkussen
D € 120
E € 155
F € 180



C06218BCAW

Back cushion Casual
Coussin dossier Casual
Casual rugkussen
D € 160
E € 190
F € 220

C06218SW

Seat cushion
Coussin d'assise
Zitkussen
D € 120
E € 155
F € 180



Plantation teak from Java
Teck de plantation de Java
Plantageteak uit Java

Plaited Tricord (polyolefin)
Tricord tressé (polyoléfine)
Geweven Tricord (polyolefine)

Lounge chair
Fauteuil lounge
Lage zetel

€ 1.695

06202-10



06202-85



D6080

Cover
Housse
Hoes
€ 230

C06202BW

Back cushion
Coussin dossier
Rugkussen
(58x36cm)

D € 230
E € 270
F € 315

C06202BCAW

Back cushion Casual
Coussin dossier Casual
Casual rugkussen

D € 590
E € 665
F € 795

C06202SW

Seat cushion
Coussin d'assise
Zitkussen

D € 690
E € 785
F € 890

C06202SW

Seat cushion
Coussin d'assise
Zitkussen

D € 690
E € 785
F € 890



Plantation teak from Java
Teck de plantation de Java
Plantageteak uit Java

Plaited Tricord (polyolefin)
Tricord tressé (polyoléfine)
Geweven Tricord (polyolefine)



2-Seater sofa
Canapé 2 places
Sofa 2-zit

06208-10

06208-85

€ 2.495

**D6085**

Cover
Housse
Hoes
€ 255

C06208BSETW

Back cushion Set D € 455
Set de coussin dossier E € 545
Rugkussen Set F € 635

C06208SW

Seat cushion D € 965
Coussin d'assise E € 1.115
Zitkussen F € 1.250

**C06208BCASETW**

Back cushion Casual Set D € 1.085
Set dossier Casual E € 1.205
Casual rugkussen Set F € 1.300

C06208SW

Seat cushion D € 965
Coussin d'assise E € 1.115
Zitkussen F € 1.250



3-Seater sofa
Canapé 3 places
Sofa 3-zit

06209-10

06209-85

€ 3.195

**D6081**

Cover
Housse
Hoes
€ 290

C06209BSETW

Back cushion Set D € 685
Set de coussin dossier E € 815
Rugkussen Set F € 950

C06209SW

Seat cushion D € 1.370
Coussin d'assise E € 1.600
Zitkussen F € 1.800

**C06209BCASETW**

Back cushion Casual Set D € 1.630
Set dossier Casual E € 1.800
Casual rugkussen Set F € 1.950

C06209SW

Seat cushion D € 1.370
Coussin d'assise E € 1.600
Zitkussen F € 1.800



Plantation teak from Java
Teck de plantation de Java
Plantageteak uit Java

Plaited Tricord (polyolefin)
Tricord tressé (polyoléfine)
Geweven Tricord (polyolefine)

Daybed
Daybed
Daybed

06249-10

06249-85

€ 4.250



D6083

Cover
Housse
Hoes
€ 385

C06249BSETW

Back cushion Set D € 685
Set de coussin dossier E € 815
Rugkussen Set F € 950

C06249SW

Seat cushion D € 1.740
Coussin d'assise E € 1.985
Zitkussen F € 2.045



C06249BCASETW

Back cushion Casual Set D € 1.630
Set dossier Casual E € 1.800
Casual rugkussen Set F € 1.950

C06249SW

Seat cushion D € 1.740
Coussin d'assise E € 1.985
Zitkussen F € 2.045



For optimal comfort, we recommend completing the daybed with deco cushions. (page 115)
Pour une ambiance confortable, nous recommandons de compléter le daybed avec des coussins déco. (pag. 115)
Voor een gezellig gevoel, raden wij aan het daybed te vervolledigen met decokussens. (pag. 115)

Lounge bed
Lounge bed
Lounge bed

06250-10

06250-85

€ 2.995



D6087

Cover
Housse
Hoes
€ 325

C06250BSETW

Back cushion Set D € 455
Set de coussin dossier E € 545
Rugkussen Set F € 635

C06250SW

Seat cushion D € 1.520
Coussin d'assise E € 1.790
Zitkussen F € 1.910



For optimal comfort, we recommend completing the daybed with deco cushions. (page 115)
Pour une ambiance confortable, nous recommandons de compléter le daybed avec des coussins déco. (pag. 115)
Voor een gezellig gevoel, raden wij aan het daybed te vervolledigen met decokussens. (pag. 115)



Plantation teak from Java
Teck de plantation de Java
Plantageteak uit Java

Ottoman
Ottoman
Ottoman

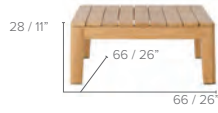

€ 805

06282

D6096

Cover
Housse
Hoes
€ 125

C06282W

Seat cushion
Coussin d'assise
Zitkussen
66x66cm
D € 725
E € 840
F € 935



D6096C

Cover with Cushion
Housse avec coussin
Hoes met kussen
€ 174

Coffee table
Table de salon
Koffietafel



€ 805

66x66cm

06282

€ 1.240

120x66cm

06284

D6096

Cover 66x66cm
Housse 66x66cm
Hoes 66x66cm
€ 125

D6108

Cover 120x66cm
Housse 120x66cm
Hoes 120x66cm
€ 185

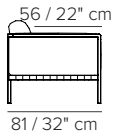
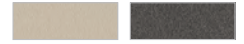

Powdercoated aluminium
Aluminium peint par poudrage
Gepoedercoat aluminium

Supporting straps in textile, plaited
Bandes de support en textile, tressées
Steunbanden in textileen, gevlochten

STAND-ALONE

	Armchair	2-Seater sofa	3-Seater sofa	NEW Pouf
Frame	05802-x € 1.245	05808S-x € 1.895	05809S-x € 3.140	05892-x € 940
Cushion	C05802W D € 1.385 E € 1.520 F € 1.710	C05808SHW D € 2.505 E € 2.840 F € 3.095	C05809SHW D € 3.425 E € 3.885 F € 4.290	C05892W D € 740 E € 835 F € 960
Cover	D5802 € 275	D5808SH € 365	D5809SH € 480	D58920 € 240

MODULAR

Cannot stand alone

	Right arm extension 2-Seater	Right arm corner module 2-Seater	Right corner extension 2-Seater	Centre module 2-Seater
Frame	05838RS-x € 1.895	05848RS-x € 1.895	05858RS-x € 1.895	05828S-x € 1.895
Cushion	C05838RSHW D € 2.340 E € 2.650 F € 3.035	C05848RSHW D € 2.670 E € 3.035 F € 3.445	C05858RSHW D € 2.620 E € 2.865 F € 3.390	C05828SHW D € 2.290 E € 2.480 F € 2.980
	Left arm extension 2-Seater	Left arm corner module 2-Seater	Left corner extension 2-Seater	
Frame	05838LS-x € 1.895	05848LS-x € 1.895	05858LS-x € 1.895	
Cushion	C05838LSHW D € 2.340 E € 2.650 F € 3.035	C05848LSHW D € 2.670 E € 3.035 F € 3.445	C05858LSHW D € 2.620 E € 2.865 F € 3.390	
	Right arm extension 3-Seater	Right arm corner module 3-Seater	Right corner extension 3-Seater	Centre module 3-Seater
Frame	05839RS-x € 3.140	05849RS-x € 3.140	05859RS-x € 3.140	05829S-x € 3.140
Cushion	C05839RSHW D € 3.180 E € 3.585 F € 4.125	C05849RSHW D € 3.510 E € 3.970 F € 4.535	C05859RSHW D € 3.450 E € 3.930 F € 4.465	C05829SHW D € 3.120 E € 3.545 F € 4.055
	Left arm extension 3-Seater	Left arm corner module 3-Seater	Left corner extension 3-Seater	
Frame	05839LS-x € 3.140	05849LS-x € 3.140	05859LS-x € 3.140	
Cushion	C05839LSHW D € 3.180 E € 3.585 F € 4.125	C05849LSHW D € 3.510 E € 3.970 F € 4.535	C05859LSHW D € 3.450 E € 3.930 F € 4.465	

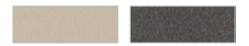

NATAL ALU SOFA DEEP WIM SEGERS

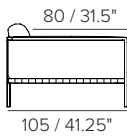

Powdercoated aluminium
Aluminium peint par poudreage
Gepoedercoat aluminium

Supporting straps in textile, plaited
Bandes de support en textile, tressées
Steunbanden in textileen, gevlochten















Casual back cushions (C02300W) recommended for optimal comfort
Coussins de dos Casual (C02300W) recommandés pour un confort optimal
Casual rugkussens (C02300W) aanbevolen voor optimaal comfort

STAND-ALONE

	 2-Seater sofa 60 / 23.5" 186 / 73.25" 42 / 16.5"	 3-Seater sofa 60 / 23.5" 273 / 107.5" 42 / 16.5"
Frame	05808D-x € 2.070	05809D-x € 3.425
Cushion	C05808DW D € 2.880 E € 3.265 F € 3.550	C05809DW D € 3.935 E € 4.465 F € 4.930
Cover	D5808D € 375	D5809D € 550

MODULAR

Cannot stand alone

	 Right arm extension 2-Seater 188 / 74"	 Right arm corner module 2-Seater	 Right corner extension 2-Seater	 Centre module 2-Seater 186 / 73.25"
Frame	05838RD-x € 2.070	05848RD-x € 2.070	05858RD-x € 2.070	05828D-x € 2.070
Cushion	C05838RDW D € 2.685 E € 3.045 F € 3.490	C05848RDW D € 3.070 E € 3.480 F € 3.970	C05858RDW D € 3.015 E € 3.285 F € 3.900	C05828DW D € 2.630 E € 2.850 F € 3.420
	 Left arm extension 2-Seater	 Left arm corner module 2-Seater	 Left corner extension 2-Seater	
Frame	05838LD-x € 2.070	05848LD-x € 2.070	05858LD-x € 2.070	
Cushion	C05838LDW D € 2.685 E € 3.045 F € 3.490	C05848LDW D € 3.070 E € 3.480 F € 3.970	C05858LDW D € 3.015 E € 3.285 F € 3.900	
	 Right arm extension 3-Seater 272 / 107"	 Right arm corner module 3-Seater	 Right corner extension 3-Seater	 Centre module 3-Seater 270 / 106.25"
Frame	05839RD-x € 3.425	05849RD-x € 3.425	05859RD-x € 3.425	05829D-x € 3.425
Cushion	C05839RDW D € 3.660 E € 4.120 F € 4.745	C05849RDW D € 4.045 E € 4.555 F € 5.225	C05859RDW D € 3.970 E € 4.515 F € 5.140	C05829DW D € 3.585 E € 4.080 F € 4.660
	 Left arm extension 3-Seater	 Left arm corner module 3-Seater	 Left corner extension 3-Seater	
Frame	05839LD-x € 3.425	05849LD-x € 3.425	05859LD-x € 3.425	
Cushion	C05839LDW D € 3.660 E € 4.120 F € 4.745	C05849LDW D € 4.045 E € 4.555 F € 5.225	C05859LDW D € 3.970 E € 4.515 F € 5.140	

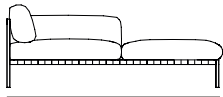
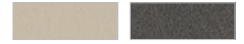

188 / 74"

Powdercoated aluminium
Aluminium peint par poudrage
Gepoedercoat aluminium

Supporting straps in textile, plaited
Bandes de support en textile, tressées
Steunbanden in textileen, gevlochten

STAND-ALONE

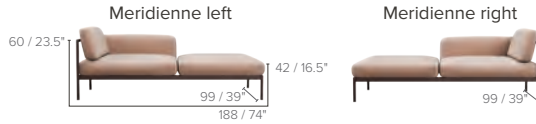

Frame

05868-x

€ 2.160

05869-x

€ 2.160

Cushion

C05868W

D € 2.005

E € 2.205

F € 2.650

C05869W

D € 2.005

E € 2.205

F € 2.650

Cover

D5868 € 440

D5869 € 440

MODULAR

Cannot stand alone

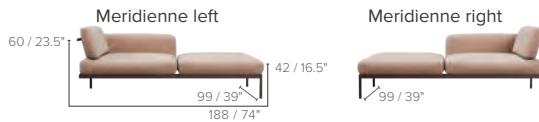

Frame

05803-x

€ 2.160

05804-x

€ 2.160

Cushion

C05803W

D € 2.005

E € 2.205

F € 2.650

C05804W

D € 2.005

E € 2.205

F € 2.650

Connector*

A58C-X

Connecteur*

Verbindingsstuk*

€ 65

*A connector is required to connect two modules lengthwise

*Un connecteur est nécessaire pour connecter deux modules dans le sens de la longueur

*Een verbindingsstuk is nodig om twee modules in de lengte met elkaar te verbinden

NATAL ALU SOFA SETS

WIM SEGERS

10-Linen 89-Wengé

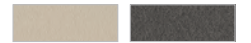

45

Custom covers = 165€ per single seat and 330€ for meridiene and daybed modules
 Housses sur mesure = 165€ par siège simple et 330€ pour les modules méridienne et daybed
 Covers op maat = 165€ per enkele zitplaats en 330€ voor meridiene en daybed modules

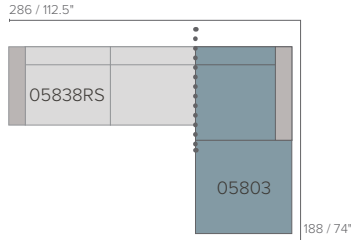

SET 1A
 Frame: 05838RS + 05803
 Cushions: C05838RSHW + C05803W

Total Price: Cat.D **€ 8.400** E **€ 8.910** F **€ 9.740**
 Cover: D5801A **€ 655**

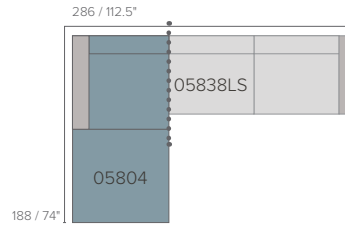

SET 1B
 Frame: 05838LS + 05804
 Cushions: C05838LSHW + C05804W

Total Price: Cat.D **€ 8.400** E **€ 8.910** F **€ 9.740**
 Cover: D5801B **€ 655**

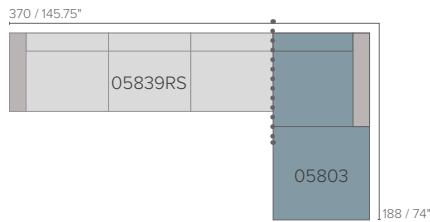

SET 2A
 Frame: 05839RS + 05803
 Cushions: C05839RSHW + C05803W

Total Price: Cat.D **€ 10.485** E **€ 11.090** F **€ 12.075**
 Cover: D5802A **€ 820**

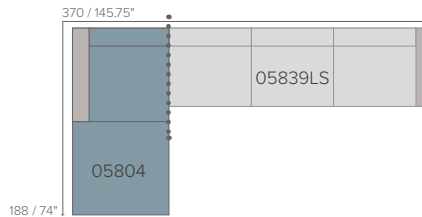

SET 2B
 Frame: 05839LS + 05804
 Cushions: C05839LSHW + C05804W

Total Price: Cat.D **€ 10.485** E **€ 11.090** F **€ 12.075**
 Cover: D5802B **€ 820**

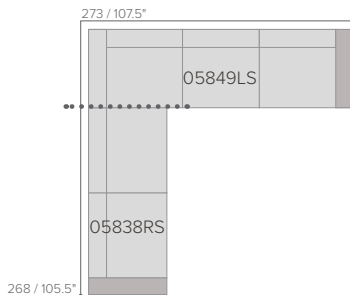

SET 3
 Frame: 05849LS + 05838RS
 Cushions: C05849LSHW + C05838RSHW

Total Price: Cat.D **€ 10.885** E **€ 11.655** F **€ 12.605**
 Cover: D5803 **€ 820**

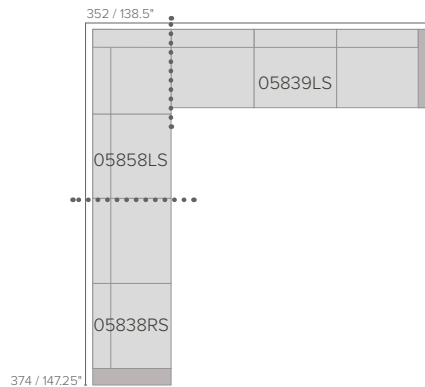

SET 4
 Frame: 05838RS + 05858LS + 05839LS
 Cushions: C05838RSHW + C05858LSHW + C05839LSHW
 Connector: A58C-x

Total Price: Cat.D **€ 15.135** E **€ 16.095** F **€ 17.545**
 Cover: D5804 **€ 1.145**

Combination examples
Exemples de combinaisons
Combinatievoorbeelden

Deep Seat =  Arm Rest = 
Meridienne Seat = 

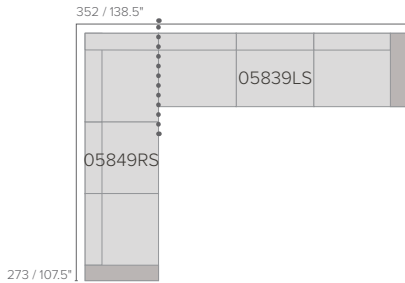

SET 5A
Frame: 05849RS + 05839LS
Cushions: C05849RSHW + C05839LSHW

Total Price: Cat.D € 12.970 E € 13.835 F € 14.940
Cover: D5805A € 980

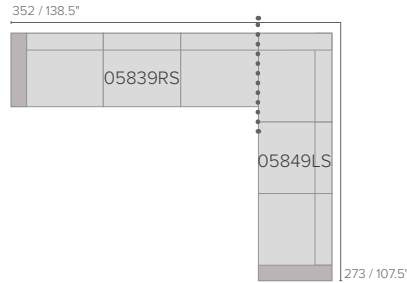

SET 5B
Frame: 05839RS + 05849LS
Cushions: C05839RSHW + C05849LSHW

Total Price: Cat.D € 12.970 E € 13.835 F € 14.940
Cover: D5805B € 980

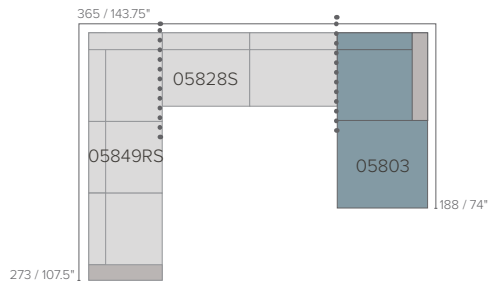

SET 6A
Frame: 05849RS + 05828S + 05803
Cushions: C05849RSHW + C05828SHW + C05803W

Total Price: Cat.D € 15.000 E € 15.850 F € 17.360
Cover: D5806A € 1.145

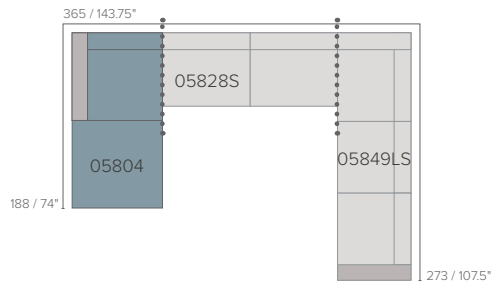

SET 6B
Frame: 05804 + 05828S + 05849LS
Cushions: C05804W + C05828SHW + C05849LSHW

Total Price: Cat.D € 15.000 E € 15.850 F € 17.360
Cover: D5806B € 1.145

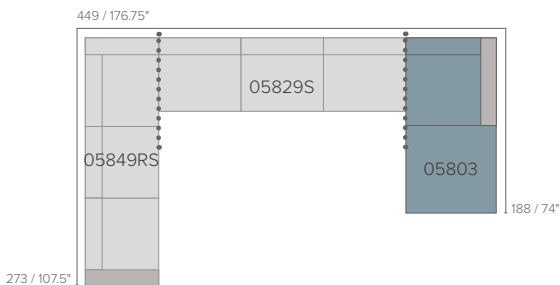

SET 7A
Frame: 05849RS + 05829S + 05803
Cushions A: C05849RSHW + C05829SHW + C05803W

Total Price: Cat.D € 17.075 E € 18.160 F € 19.680
Cover: D5807A € 1.310

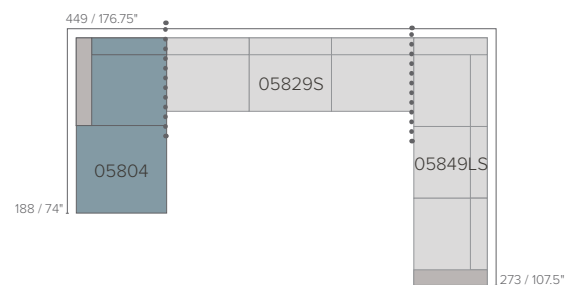

SET 7B
Frame: 05804 + 05829S + 05849LS
Cushions: C05804W + C05829SHW + C05849LSHW

Total Price: Cat.D € 17.075 E € 18.160 F € 19.680
Cover: D5807B € 1.310

Combination examples
Exemples de combinaisons
Combinatievoorbeelden

Deep Seat =  Arm Rest = 
Meridienne Seat = 

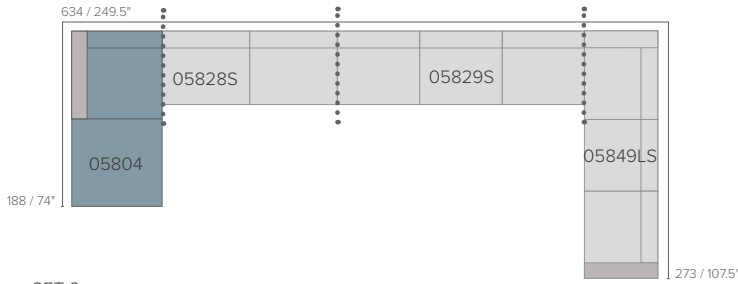

SET 9
Frame: 05804 + 05828S + 05829S + 05849LS
Cushions: C05804W + C05828SHW + C05829SHW + C05849LSHW
Connector: A58C-x

Total Price: Cat.D **€ 21.325** E **€ 22.600** F **€ 24.620**
Cover: D5809 **€ 1.635**

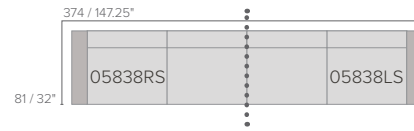

SET 10
Frame: 05838RS + 05838LS
Cushions: C05838RSHW + C05838LSHW
Connector: A58C-x

Total Price: Cat.D **€ 8.535** E **€ 9.155** F **€ 9.925**
Cover: D5810 **€ 655**

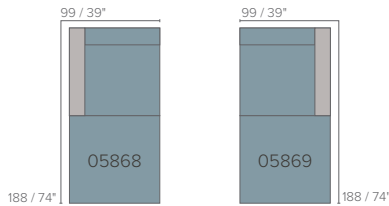

SET 11
Frame: 05868 + 05869
Cushions: C05868W + C05869W

Total Price: Cat.D **€ 8.330** E **€ 8.730** F **€ 9.620**
Cover D5868 + D5869: **€ 440 + € 440 = 880 €**

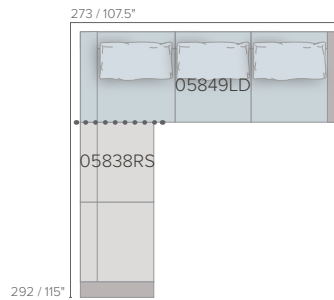

SET 12
Frame: 05838RS + 05849LD
Cushions: C05838RSHW + C05849LDW
Casual back cushion: 3x C02300W

Total Price: Cat.D **€ 12.755** E **€ 13.815** F **€ 15.020**
Cover: D5812 **€ 820**

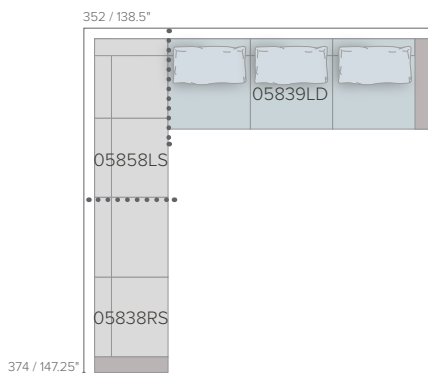

SET 13
Frame: 05838RS + 05858LS + 05839LD
Cushions: C05838RSHW + C05858LSHW + C05839LDW
Casual back cushion: 3x C02300W
Connector: A58C-x

Total Price: Cat.D **€ 16.950** E **€ 18.205** F **€ 19.890**
Cover: D5813 **€ 1.145**

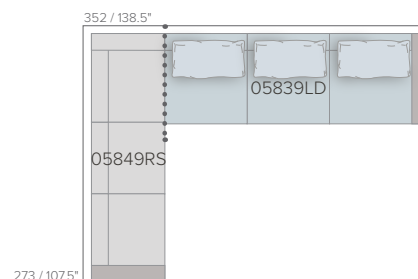

SET 14
Frame: 05849RS + 05839LD
Cushions: C05849RSHW + C05839LDW
Casual back cushion: 3x C02300W

Total Price: Cat.D **€ 14.785** E **€ 15.945** F **€ 17.285**
Cover: D5814 **€ 980**

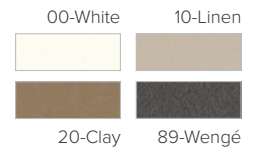

Powdercoated aluminium
Aluminium laqué par poudrage
Gepoedercoat aluminium

Coffee table high round
Table de salon ronde
Koffietafel hoog rond

€ 575



D6176
Cover
Housse
Hoes
€ 145



Coffee table low 40x40cm
Table de salon basse 40x40cm
Koffietafel laag 40x40cm

€ 645

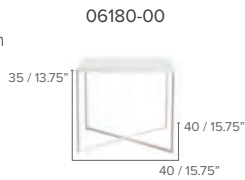

D6180
Cover
Housse
Hoes
€ 165



Coffee table low 60x60cm
Table de salon basse 60x60cm
Koffietafel laag 60x60cm

€ 1.050

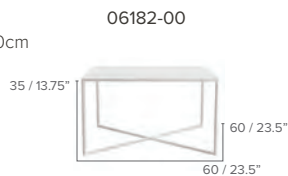

D6182
Cover
Housse
Hoes
€ 180



Powdercoated stainless steel
Inox laqué par poudrage
Gepoedercoat inox

Canax®
Canax®
Canax®

Armchair
Fauteuil repas
Armstoel

€ 1.250

01918-00-00/10



01918-89-10



D1918
Cover
Housse
Hoes
€ 235

C01918SW
Seat cushion D € 165
Coussin d'assise E € 190
Zitkussen F € 210



Lounge chair
Fauteuil
Lage stoel

€ 1.450

01912-00-00/10



01912-89-10



D1912
Cover
Housse
Hoes
€ 245

C01912SW
Seat cushion D € 180
Coussin d'assise E € 200
Zitkussen F € 220



L Lounger, adjustable
Chaise longue, réglable
Ligbed, verstelbaar

€ 3.600

01940-00-00/10



01940-89-10



D1940
Cover
Housse
Hoes
€ 305

C01940W
Cushion D € 605
Coussin E € 715
Kussen F € 830



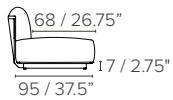
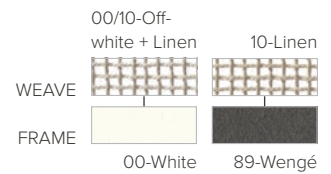

Powdercoated aluminium
Aluminium peint par poudrage
Gepoedercoat aluminium

Powdercoated stainless steel
Inox laqué par poudrage
Gepoedercoat inox

Canax®
Canax®
Canax®

Single module
Module 1-place
Enkele module

€ 1.620

01950-00-00/10



01950-89-10



D1950
Cover
Housse
Hoes
€ 240

C01902BW
Back cushion
Coussin dossier
Rugkussen
D € 580
E € 650
F € 705

C01902SW
Seat cushion
Coussin d'assise
Zitkussen
D € 1.255
E € 1.355
F € 1.450



Corner module
Module coin
Hoekmodule

€ 2.250

01951-x-y
Left arm + Back



01952-x-y
Right arm + Back



01953-x-y
Left arm + Corner



01954-x-y
Right arm + Corner

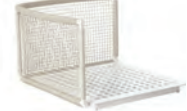

C01902BW
Back cushion
Coussin dossier
Rugkussen
D € 580
E € 650
F € 705

C01902SW
Seat cushion
Coussin d'assise
Zitkussen
D € 1.255
E € 1.355
F € 1.450

C01902BW
Back cushion
Coussin dossier
Rugkussen
D € 580
E € 650
F € 705

C01902SW
Seat cushion
Coussin d'assise
Zitkussen
D € 1.255
E € 1.355
F € 1.450

C01901BW
Corner Back cushion
Coussin dossier d'angle
Hoek rugkussen
D € 1.130
E € 1.250
F € 1.355

C01902SW
Seat cushion
Coussin d'assise
Zitkussen
D € 1.255
E € 1.355
F € 1.450

C01901BW
Corner Back cushion
Coussin dossier d'angle
Hoek rugkussen
D € 1.130
E € 1.250
F € 1.355

C01902SW
Seat cushion
Coussin d'assise
Zitkussen
D € 1.255
E € 1.355
F € 1.450

Cover **D1951** € 260



D1952 € 260



D1953 € 260



D1954 € 260



Pouf
Pouf
Poef

€ 1.090

01955-00



01955-89

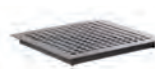

D1955
Cover
Housse
Hoes
€ 195

C01902SW
Seat cushion
Coussin d'assise
Zitkussen
D € 1.255
E € 1.355
F € 1.450



Corner Connector*
Connecteur d'angle*
Hoek Verbindingsstuk*
€ 67

*A connector is needed to create a corner sofa
*Un connecteur est nécessaire pour créer un canapé d'angle
*Een verbindingsstuk is nodig om een hoek-sofa te vormen

NODI SOFA DEEP YABU PUSHELBERG

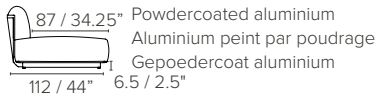
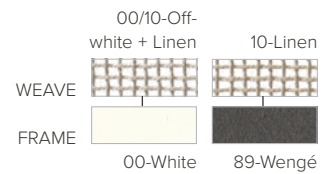

Powdercoated aluminium
Aluminium peint par poudrage
Gepoedercoat aluminium

Powdercoated stainless steel
Inox laqué par poudrage
Gepoedercoat inox

Canax*
Canax*
Canax*

Casual back cushions (C02300W) recommended for optimal comfort
Coussins de dos Casual (C02300W) recommandés pour un confort optimal
Casual rugkussens (C02300W) aanbevolen voor optimaal comfort

Single module deep
Module 1-place profonde
Enkele module diep

€ 2.225

01960-00-00/10



01960-89-10

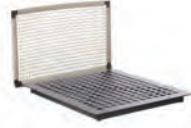

D1960
Cover
Housse
Hoes
€ 255

C01902BW
Back cushion
Coussin dossier
Rugkussen

D € 580
E € 650
F € 705

C01903SW
Seat cushion
Coussin d'assise
Zitkussen

D € 1.450
E € 1.570
F € 1.680

C02300W

Option Casual back cushion
Option Coussin dossier Casual
Optie Casual Rugkussen

D € 350
E € 430
F € 480



Corner module deep
Module coin profonde
Hoekmodule diep

€ 2.650

01961-x-y
Left arm + Back



01962-x-y
Right arm + Back



01963-x-y
Left arm + Corner



01964-x-y
Right arm + Corner

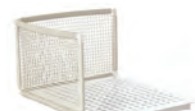

C01902BW
Back cushion
Coussin dossier
Rugkussen

D € 580
E € 650
F € 705

C01902BW
Back cushion
Coussin dossier
Rugkussen

D € 580
E € 650
F € 705

C01901BW
Corner Back cushion
Coussin dossier d'angle
Hoek rugkussen

D € 1.130
E € 1.250
F € 1.355

C01901BW
Corner Back cushion
Coussin dossier d'angle
Hoek rugkussen

D € 1.130
E € 1.250
F € 1.355

C01903SW
Seat cushion
Coussin d'assise
Zitkussen

D € 1.450
E € 1.570
F € 1.680

C01903SW
Seat cushion
Coussin d'assise
Zitkussen

D € 1.450
E € 1.570
F € 1.680

C01903SW
Seat cushion
Coussin d'assise
Zitkussen

D € 1.450
E € 1.570
F € 1.680

C01903SW
Seat cushion
Coussin d'assise
Zitkussen

D € 1.450
E € 1.570
F € 1.680

Cover **D1961** € 305



D1962 € 305



D1963 € 305



D1964 € 305



Pouf deep
Pouf profonde
Poef diep

€ 1.690

01965-00



01965-89

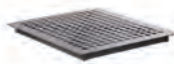

D1965
Cover
Housse
Hoes
€ 205

C01903SW
Seat cushion
Coussin d'assise
Zitkussen

D € 1.450
E € 1.570
F € 1.680



Corner Connector*
Connecteur d'angle*
Hoek Verbindingsstuk* € 67

*A connector is needed to create a corner sofa
*Un connecteur est nécessaire pour créer un canapé d'angle
*Een verbindingsstuk is nodig om een hoek-sofa te vormen

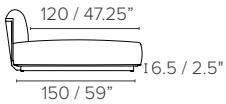
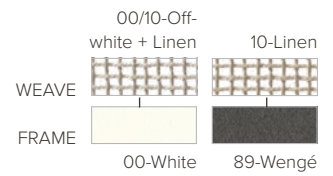

Powdercoated aluminium
Aluminium peint par poudrage
Gepoedercoat aluminium

Powdercoated stainless steel
Inox laqué par poudrage
Gepoedercoat inox

Canax®
Canax®
Canax®

Lounge daybed
Lounge daybed
Lounge daybed

€ 2.290

01970-00-00/10



01970-89-10



D1970
Cover
Housse
Hoes
€ 300

C01902BW
Back cushion
Coussin dossier
Rugkussen

D € 580
E € 650
F € 705

C01904SW
Seat cushion
Coussin d'assise
Zitkussen

D € 1.900
E € 2.045
F € 2.195



Lounge corner
Lounge coin
Lounge hoek

€ 2.730

01971-x-y
Left arm + Back



01972-x-y
Right arm + Back



01973-x-y
Left arm + Corner

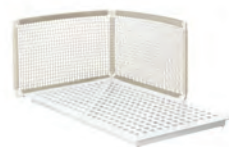

01974-x-y
Right arm + Corner



C01902BW
Back cushion
Coussin dossier
Rugkussen

D € 580
E € 650
F € 705

C01902BW
Back cushion
Coussin dossier
Rugkussen

D € 580
E € 650
F € 705

C01901BW
Corner Back cushion
Coussin dossier d'angle
Hoek rugkussen

D € 1.130
E € 1.250
F € 1.355

C01901BW
Corner Back cushion
Coussin dossier d'angle
Hoek rugkussen

D € 1.130
E € 1.250
F € 1.355

C01904SW
Seat cushion
Coussin d'assise
Zitkussen

D € 1.900
E € 2.045
F € 2.195

C01904SW
Seat cushion
Coussin d'assise
Zitkussen

D € 1.900
E € 2.045
F € 2.195

C01904SW
Seat cushion
Coussin d'assise
Zitkussen

D € 1.900
E € 2.045
F € 2.195

C01904SW
Seat cushion
Coussin d'assise
Zitkussen

D € 1.900
E € 2.045
F € 2.195



Pouf lounge
Pouf lounge
Lounge poef

€ 1.760

01975-00



01975-89

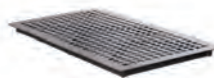

D1975
Cover
Housse
Hoes
€ 215

C01904SW
Seat cushion
Coussin d'assise
Zitkussen

D € 1.900
E € 2.045
F € 2.195



NODI SOFA MERIDIENNE YABU PUSHELBERG

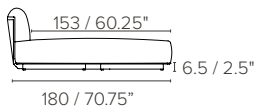
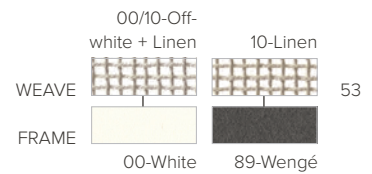

Powdercoated aluminium
Aluminium peint par poudrage
Gepoedercoat aluminium

Powdercoated stainless steel
Inox laqué par poudrage
Gepoedercoat inox

Canax®
Canax®
Canax®

Meridienne daybed
Meridienne daybed
Meridienne daybed

€ 2.705

01980-00-00/10



01980-89-10



D1980
Cover
Housse
Hoes
€ 330

C01902BW
Back cushion
Coussin dossier
Rugkussen

D € 580
E € 650
F € 705

C01905SW
Seat cushion
Coussin d'assise
Zitkussen

D € 2.275
E € 2.455
F € 2.635



Meridienne corner
Meridienne coin
Meridienne hoek

€ 3.135

01981-x-y
Left arm + back



01982-x-y
Right arm + Back



01983-x-y
Left arm + Corner



01984-x-y
Right arm + Corner



C01902BW
Back cushion
Coussin dossier
Rugkussen

D € 580
E € 650
F € 705

C01902BW
Back cushion
Coussin dossier
Rugkussen

D € 580
E € 650
F € 705

C01901BW
Corner Back cushion
Coussin dossier d'angle
Hoek rugkussen

D € 1.130
E € 1.250
F € 1.355

C01901BW
Corner Back cushion
Coussin dossier d'angle
Hoek rugkussen

D € 1.130
E € 1.250
F € 1.355

C01905SW
Seat cushion
Coussin d'assise
Zitkussen

D € 2.275
E € 2.455
F € 2.635

C01905SW
Seat cushion
Coussin d'assise
Zitkussen

D € 2.275
E € 2.455
F € 2.635

C01905SW
Seat cushion
Coussin d'assise
Zitkussen

D € 2.275
E € 2.455
F € 2.635

C01905SW
Seat cushion
Coussin d'assise
Zitkussen

D € 2.275
E € 2.455
F € 2.635

Cover **D1981**

€ 355



D1982

€ 355



D1983

€ 355



D1984

€ 355



Pouf XL
Pouf XL
Poef XL

€ 2.175

01985-00



01985-89

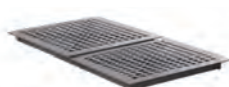

D1985
Cover
Housse
Hoes
€ 220

C01905SW
Seat cushion
Coussin d'assise
Zitkussen

D € 2.275
E € 2.455
F € 2.635

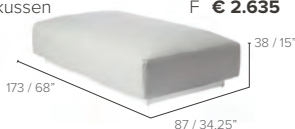

Corner Connector*
Connecteur d'angle*
Hoek Verbindingsstuk*

A1905-xx

€ 67

*A connector is needed to create a corner sofa
*Un connecteur est nécessaire pour créer un canapé d'angle
*Een verbindingsstuk is nodig om een hoek-sofa te vormen

Custom covers = 165€ per single seat and 330€ for meridiene and daybed modules
 Housses sur mesure = 165€ par siège simple et 330€ pour les modules méridienne et daybed
 Covers op maat = 165€ per enkele zitplaats en 330€ voor meridiene en daybed modules

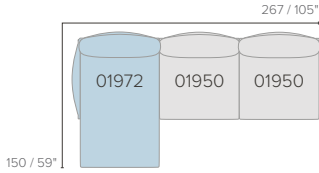
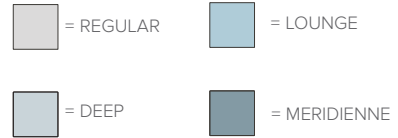

SET 1
 Frame: 01972 + 2x 01950
 Cushions: 3x C01902B + C01904S + 2x C01902S

Total price: Cat. D **€ 12.120** E **€ 12.675** F **€ 13.180**
 Total price with corner cushion Cat. D **€ 12.670** E **€ 13.275** F **€ 13.830**
 Cover: D1921 **€ 655** Cover with corner cushion: D2000 **€ 655**

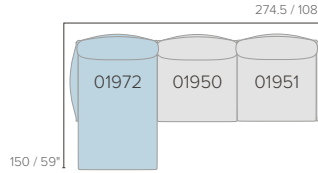

SET 2
 Frame: 01972 + 01950 + 01951
 Cushions: 3x C01902B + C01904S + 2x C01902S

Total price: Cat. D **€ 12.750** E **€ 13.305** F **€ 13.810**
 Total price with corner cushions at sofa ends Cat. D **€ 13.850** E **€ 14.505** F **€ 15.110**
 Cover: D1922 **€ 655** Cover with corner cushions at sofa ends: D1922C **€ 655**

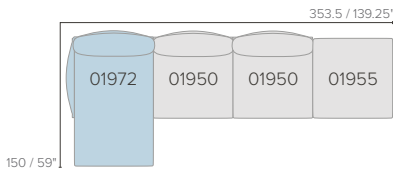

SET 3
 Frame: 01972 + 2x 01950 + 01955
 Cushions: 3x C01902B + C01904S + 3x C01902S

Total price: Cat. D **€ 14.465** E **€ 15.120** F **€ 15.720**
 Total price with corner cushion Cat. D **€ 15.015** E **€ 15.720** F **€ 16.370**
 Cover: D1923 **€ 820** Cover with corner cushion: D1923C **€ 820**

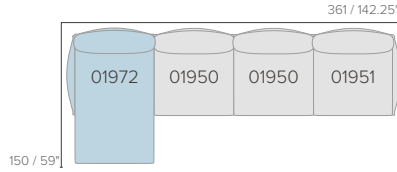

SET 4
 Frame: 01972 + 2x 01950 + 01951
 Cushions: 4x C01902B + C01904S + 3x C01902S

Total price: Cat. D **€ 16.205** E **€ 16.930** F **€ 17.585**
 Total price with corner cushions at sofa ends Cat. D **€ 17.305** E **€ 18.130** F **€ 18.885**
 Cover: D1924 **€ 820** Cover with corner cushions at sofa ends: D1924C **€ 820**

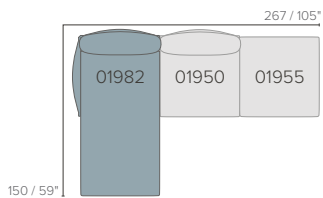

SET 5
 Frame: 01982 + 01950 + 01955 + A1905
 Cushions: 2x C01902B + C01905S + 2x C01902S

Total price: Cat. D **€ 11.857** E **€ 12.377** F **€ 12.857**
 Total price with corner cushion Cat. D **€ 12.407** E **€ 12.977** F **€ 13.507**
 Cover: D1925 **€ 655** Cover with corner cushion: D1925C **€ 655**

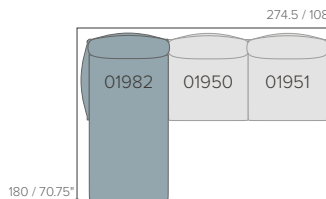

SET 6
 Frame: 01982 + 01950 + 01951 + A1905
 Cushions: 3x C01902B + C01905S + 2x C01902S

Total price: Cat. D **€ 13.597** E **€ 14.187** F **€ 14.722**
 Total price with corner cushions at sofa ends Cat. D **€ 14.697** E **€ 15.387** F **€ 16.022**
 Cover: D1926 **€ 655** Cover with corner cushions at sofa ends: D1926C **€ 655**

Combination examples
Exemples de combinaisons
Combinatievoorbeelden

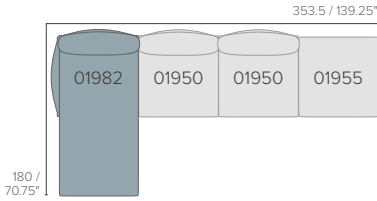

SET 7

Frame: 01982 + 2x 01950 + 01955 + A1905
Cushions: 3x C01902B + C01905S + 3x C01902S

Total price: Cat. D **€ 15.312** E **€ 16.002** F **€ 16.632**
Total price with corner cushion Cat. D **€ 15.862** E **€ 16.602** F **€ 17.282**
Cover: D1927 **€ 820** Cover with corner cushion: D1927C **€ 820**

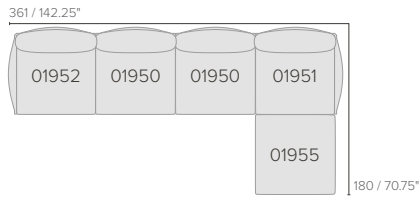

SET 8

Frame: 01952 + 2x 01950 + 01951 + 01955 + A1905
Cushions: 4x C01902B + 5x C01902S

Total price: Cat. D **€ 17.492** E **€ 18.272** F **€ 18.967**
Total price with corner cushions at sofa ends Cat. D **€ 18.592** E **€ 19.472** F **€ 20.267**
Cover: D1928 **€ 820** Cover with corner cushions at sofa ends: D1928C **€ 820**

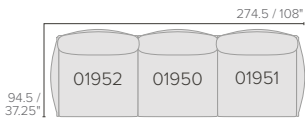

SET 9

Frame: 01952 + 01950 + 01951
Cushions: 3x C01902B + 3x C01902S

Total price: Cat. D **€ 11.625** E **€ 12.135** F **€ 12.585**
Total price with corner cushions at sofa ends Cat. D **€ 12.725** E **€ 13.335** F **€ 13.885**
Cover: D1929 **€ 490** Cover with corner cushions at sofa ends: D2003 **€ 490**

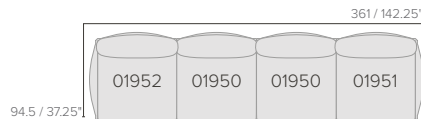

SET 10

Frame: 01952 + 2x 01950 + 1x 01951
Cushions: 4x C01902B + 4x C01902S

Total price: Cat. D **€ 15.080** E **€ 15.760** F **€ 16.360**
Total price with corner cushions at sofa ends Cat. D **€ 16.180** E **€ 16.960** F **€ 17.660**
Cover: D1930 **€ 655** Cover with corner cushions at sofa ends: D2025 **€ 655**

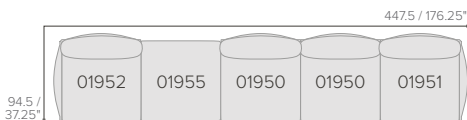

SET 11

Frame: 01952 + 01955 + 2x 01950 + 1x 01951
Cushions: 4x C01902B + 5x C01902S

Total price: Cat. D **€ 17.425** E **€ 18.205** F **€ 18.900**
Total price with corner cushions at sofa ends Cat. D **€ 18.525** E **€ 19.405** F **€ 20.200**
Cover: D1931 **€ 820** Cover with corner cushions at sofa ends: D1931C **€ 820**

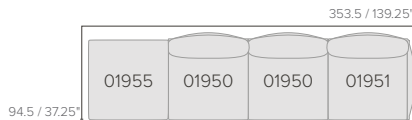

SET 12

Frame: 01955 + 2x 01950 + 01951
Cushions: 3x C01902B + 4x C01902S

Total price: Cat. D **€ 13.340** E **€ 13.950** F **€ 14.495**
Total price with corner cushion Cat. D **€ 13.890** E **€ 14.550** F **€ 15.145**
Cover: D1932 **€ 655** Cover with corner cushions: D1932C **€ 655**

Combination examples
Exemples de combinaisons
Combinatievoorbeelden

 = REGULAR  = LOUNGE

 = DEEP  = MERIDIENNE

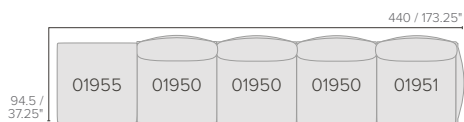

SET 13

Frame: 01955 + 3x 01950 + 01951
Cushions: 4x C01902B + 5x C01902S

Total price: Cat. D **€ 16.795** E **€ 17.575** F **€ 18.270**
Total price with corner cushion Cat. D **€ 17.345** E **€ 18.175** F **€ 18.920**
Cover: D1933 **€ 820** Corner cushion at sofa end: D1933C **€ 820**

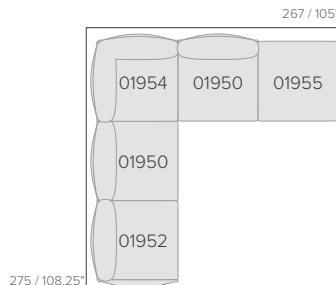

SET 14

Frame: 01952 + 2x 01950 + 01954 + 01955 + A1905
Cushions: C01901B + 3x C01902B + 5x C01902S

Total price: Cat. D **€ 18.042** E **€ 18.872** F **€ 19.617**
Total price with extra corner cushion Cat. D **€ 18.592** E **€ 19.472** F **€ 20.267**
Cover: D1934 **€ 820** Cover with corner cushion at sofa end: D1934C **€ 820**

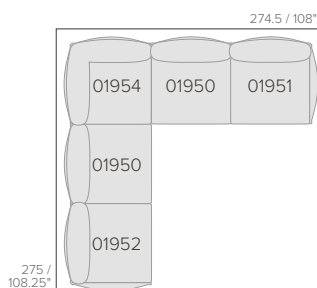

SET 15

Frame: 01952 + 2x 01950 + 01954 + 01951 + A1905
Cushions: C01901B + 4x C01902B + 5x C01902S

Total price: Cat. D **€ 19.782** E **€ 20.682** F **€ 21.482**
Total price with corner cushions at sofa ends Cat. D **€ 20.882** E **€ 21.882** F **€ 22.782**
Cover: D1935 **€ 820** Cover with corner cushions at sofa ends: D1935C **€ 820**

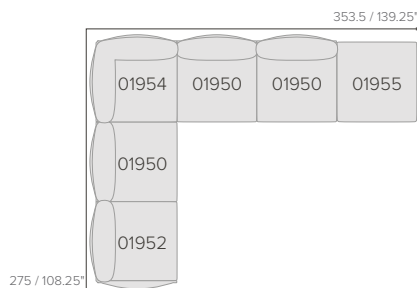

SET 16

Frame: 01952 + 3x 01950 + 01954 + 01955 + A1905
Cushions: C01901B + 4x C01902B + 6x C01902S

Total price: Cat. D **€ 21.497** E **€ 22.497** F **€ 23.392**
Total price with extra corner cushion Cat. D **€ 22.047** E **€ 23.097** F **€ 24.042**
Cover: D1936 **€ 980** Cover with corner cushion at sofa end: D1936C **€ 980**

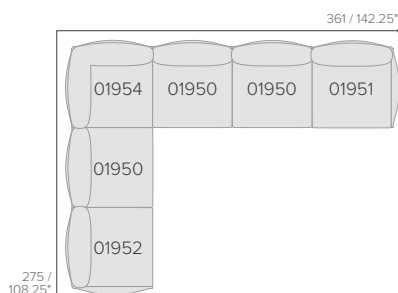

SET 17

Frame: 01952 + 3x 01950 + 01954 + 01951 + A1905
Cushions: C01901B + 5x C01902B + 6x C01902S

Total price: Cat. D **€ 23.237** E **€ 24.307** F **€ 25.257**
Total price with corner cushions at sofa ends Cat. D **€ 24.337** E **€ 25.507** F **€ 26.557**
Cover: D1937 **€ 980** Cover with corner cushions at sofa ends: D1937C **€ 980**

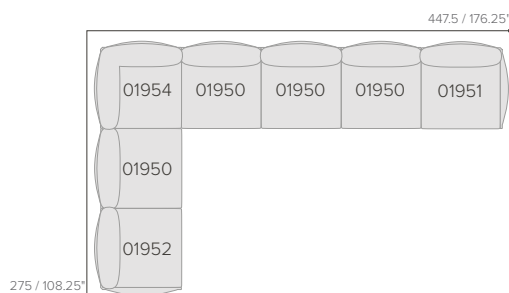

SET 18

Frame: 01952 + 4x 01950 + 01954 + 01951 + A1905
Cushions: C01901B + 6x C01902B + 7x C01902S

Total price: Cat. D **€ 26.692** E **€ 27.932** F **€ 29.032**
Total price with corner cushions at sofa ends Cat. D **€ 27.792** E **€ 29.132** F **€ 30.332**
Cover: D1938 **€ 1.145** Cover with corner cushion at sofa ends: D1938C **€ 1.145**

Combination examples
Exemples de combinaisons
Combinatievoorbeelden

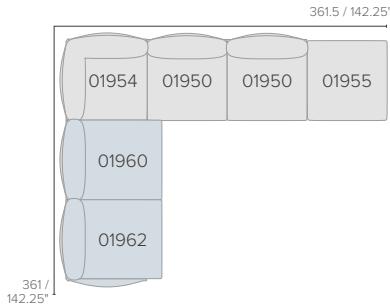
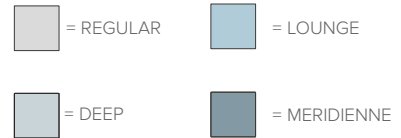

SET 19
Frame: 01962 + 01960 + 01954 + 2x 01950 + 01955 + A1905
Cushions: 2x C01903S + 4x C01902B + C01901B + 4x C01902S

Total price: Cat. D **€ 22.892** E **€ 23.932** F **€ 24.857**
Total price with extra corner cushion Cat. D **€ 23.442** E **€ 24.532** F **€ 25.507**
Cover: D1939 **€ 980** Cover with corner cushion at sofa end: D1939C **€ 980**

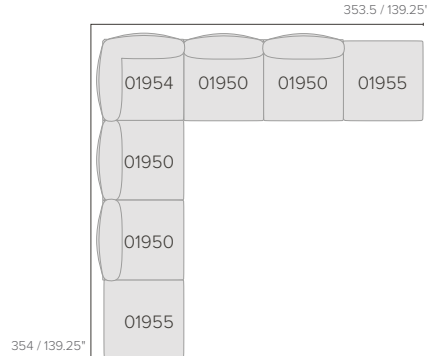

SET 20
Frame: 2x 01955 + 4x 01950 + 01954 + A1905
Cushions: C01901B + 4x C01902B + 7x C01902S

Total price: Cat. D **€ 23.212** E **€ 24.312** F **€ 25.302**
Cover: D1941 **€ 1.145**

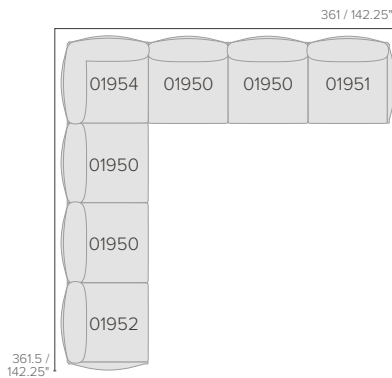

SET 21
Frame: 01952 + 4x 01950 + 01954 + 01951 + A1905
Cushions: C01901B + 6x C01902B + 7x C01902S

Total price: Cat. D **€ 26.692** E **€ 27.932** F **€ 29.032**
Total price with corner cushions at sofa ends Cat. D **€ 27.792** E **€ 29.132** F **€ 30.332**
Cover: D1942 **€ 1.145** Cover with corner cushions at sofa ends: D1942C **€ 1.145**

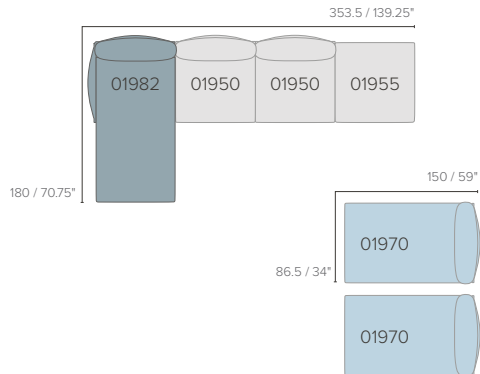

SET 22
Frame: 01982 + 2x 01950 + 01955 + 2x 01970 + A1905
Cushions: 5x C01902B + C01905S + 3x C01902S + 2x C01904S

Total price: Cat. D **€ 24.852** E **€ 25.972** F **€ 27.012**
Total price with corner cushion Cat. D **€ 25.402** E **€ 26.572** F **€ 27.662**
Cover: D1927 + 2x D1970 = **€ 820 + 2x € 300 = 1.300 €**
Cover with corner cushion: D1927C + 2x D1970 = **€ 820 + 2x € 300 = 1.300 €**

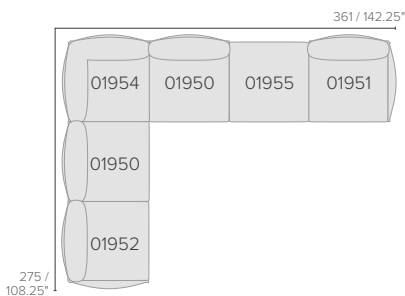

SET 24
Frame: 01952 + 2x 01950 + 01954 + 01955 + 01951 + A1905
Cushions: C01901B + 4x C01902B + 6x C01902S

Total price: Cat. D **€ 22.127** E **€ 23.127** F **€ 24.022**
Total price with corner cushions at sofa ends Cat. D **€ 23.227** E **€ 24.327** F **€ 25.322**
Cover: D1944 **€ 980** Cover with corner cushions at sofa ends: D1944C **€ 980**

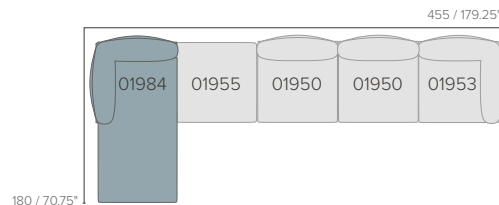

SET 25
Frame: 01984 + 01955 + 2x 01950 + 01953 + A1905
Cushions: C01905S + 4x C01902S + 2x C01901B + 2x C01902B

Total price: Cat. D **€ 20.497** E **€ 21.457** F **€ 22.337**
Cover without corner cushions at sofa ends: D1945 **€ 980** Cover: D1945C **€ 980**



Plantation teak from Java
Teck de plantation de Java
Plantageteak uit Java

Armchair
Fauteuil repas
Armstoel

05018

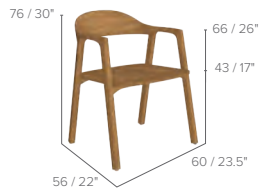

€ 1.685

D5024

Cover
Housse
Hoes
€ 200

C05018W

Seat & back cushion D € 715
Coussin d'assise et de dossier E € 820
Zit-en rugkussen F € 935

**C05018SW**

Seat cushion D € 255
Coussin d'assise E € 345
Zitkussen F € 490



Lounge chair
Fauteuil
Lage stoel

05012



€ 2.275

D5012

Cover
Housse
Hoes
€ 240

C05012W

Seat & back cushion D € 1.385
Coussin d'assise et de dossier E € 1.455
Zit-en rugkussen F € 1.645

**C05012SW**

Seat cushion D € 435
Coussin d'assise E € 590
Zitkussen F € 750



Powdercoated stainless steel
Inox laqué par poudrage
Gepoedercoat inox

Table top: glazed lava stone or ceramic
Dessus de table: pierre de lave émaillée ou céramique
Tafelblad: geglazuurde lavasteen of keramiek

*This colour may possibly show veins
*Des veines peuvent éventuellement figurer sur cette couleur
*Deze kleur kan mogelijk anders vertonen

Dining table 264 cm
Table à manger 264 cm
Eettafel 264 cm



x-Table top: glazed Lava stone or Ceramic
x-Dessus de table: pierre de lave émaillée ou céramique
x-Tafelblad: geglazuurde lavasteen of keramiek

€ 14.685
€ 11.400

02252-00-Lx
02252-00-Cx

02252-10-Lx
02252-10-Cx

02252-89-Lx
02252-89-Cx

Dining table 352 cm
Table à manger 352 cm
Eettafel 352 cm

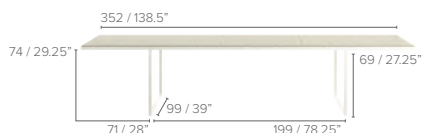

€ 18.130
€ 13.680

02254-00-Lx
02254-00-Cx

02254-10-Lx
02254-10-Cx

02254-89-Lx
02254-89-Cx

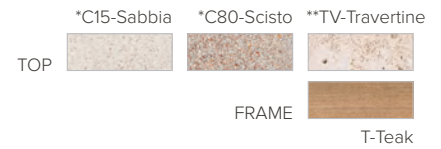

Plantation teak from Java
Teck de plantation de Java
Plantageteak uit Java

** This material is sensitive to stains
** Ce matériau est sensible aux taches
** Dit materiaal is vlekgevoelig

*This colour may possibly show veins.
*Des veines peuvent éventuellement figurer sur cette couleur
*Deze kleur kan mogelijk anders vertonen.

Dining Table - Dia 148cm



€ 6.100 Ceramic
€ 11.000 Travertine

04266-Cx

04266-TV

NEW Low Dining Table - Dia 148cm



€ 6.000 Ceramic
€ 10.900 Travertine

04267-Cx

04267-TV

Dining Table - 320x110cm



€ 9.990 Ceramic

04254-Cx

Dining Table - 290x110cm



€ 13.905 Travertine

04253-TV

Note: the height and clearance under the table may differ according to the type of table top. Please consult the product sheet on our website.

Remarque: la hauteur et le dégagement sous la table peuvent différer selon le type de dessus de table. Pour plus de détails, consultez la fiche produit sur notre site internet.

Opmerking: afhankelijk van het type tafelblad kunnen de hoogte en de vrije ruimte onder de tafel verschillen. Details vindt u op de productfiche op onze website.

Covers for tables see p.124-127
Des housses pour les tables voir p.124-127
Hoezen voor tafels zie p.124-127

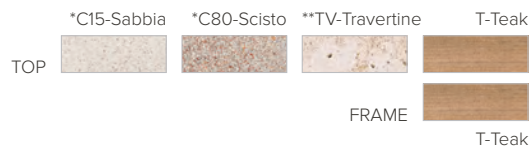

Plantation teak from Java
Teck de plantation de Java
Plantageteak uit Java

** This material is sensitive to stains
** Ce matériau est sensible aux taches
** Dit materiaal is vlekgevoelig

*This colour may possibly show veins.
*Des veines peuvent éventuellement figurer sur cette couleur
*Deze kleur kan mogelijk anders vertonen.

Side Table - H32cm



€ 1.495 Ceramic
€ 1.495 Teak
€ 2.100 Travertine

04281-Cx
04281-T
04281-TV

€ 1.695 Ceramic
€ 1.695 Teak
€ 2.600 Travertine

04283-Cx
04283-T
04283-TV

€ 2.145 Ceramic
€ 2.145 Teak
€ 4.600 Travertine

04284-Cx
04284-T
04284-TV

Side Table - H45cm

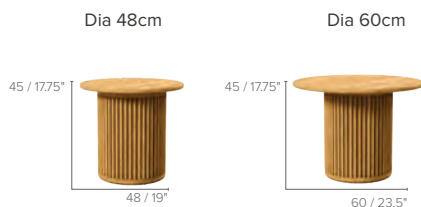

€ 1.595 Ceramic
€ 1.595 Teak
€ 2.200 Travertine

04280-Cx
04280-T
04280-TV

€ 1.795 Ceramic
€ 1.795 Teak
€ 2.600 Travertine

04282-Cx
04282-T
04282-TV

Powdercoated aluminium
Aluminium laqué par poudrage
Gepoedercoat aluminium

Plantation teak from Java
Teck de plantation de Java
Plantageteak uit Java

Sunscape
Sunscape
Sunscape

Base
Base
Basis

€ 5.915

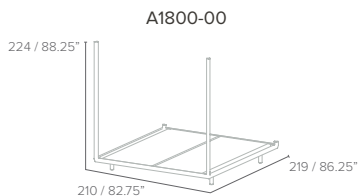

A1800-00



A1800-89

D1800C
Cover*
House*
Hoes*
€ 385

C01800SETW
Cushion set
Set Coussin
Kussen set

D € 2.440
E € 2.640
F € 2.845

*Cover: covers the cushions only and is included in the article ref. and the price of the frame structure.

*Housse: couvre seulement les coussins et est inclus dans le code article et le prix du cadre.

*Hoes: bedekt enkel de kussens en is inbegrepen in de artikelcode en de prijs van het frame

Rear wall - Aluminium
Paroi arrière - Aluminium
Achterwand - Aluminium

€ 3.055

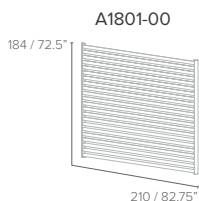

A1801-00

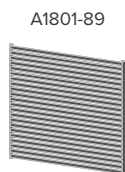

A1801-89

Rear wall - Sunscape
Paroi arrière - Sunscape
Achterwand - Sunscape

€ 2.420

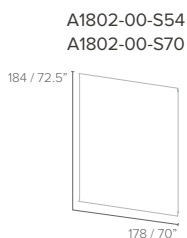

A1802-00-S54
A1802-00-S70

A1802-89-S64



Sunscape:



Rear wall - Teak
Paroi arrière - Teck
Achterwand - Teak

€ 3.695

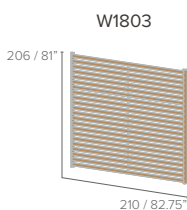

W1803



T-Teak

Rear wall - Empty
Paroi arrière - Vide
Achterwand - Leeg

€ 1.140



A1804-00

A1804-89



PAVILION DAYBED

MONICA ARMANI

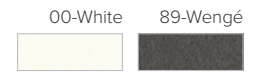

Powdercoated aluminium
Aluminium laqué par poudrage
Gepoedercoat aluminium

Plantation teak from Java
Teck de plantation de Java
Plantageteak uit Java

Sunscape
Sunscape
Sunscape

Curtains in Sunbrella Velum
Rideaux en Sunbrella Velum
Gordijnen in Sunbrella Velum

Roof - Aluminium
Toit - Aluminium
Dak - Aluminium

€ 4.435

A1805-00

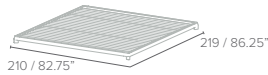

A1805-89

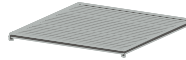

Roof - movable Sunscape
Toit - Sunscape amovible
Dak - wegschuifbare Sunscape

€ 3.800

A1807-00-S54
A1807-00-S70

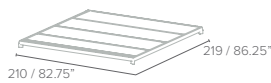

A1807-89-S64

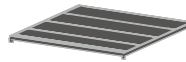

Sunscape:

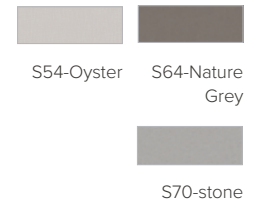

Roof - Teak
Toit - Teck
Dak - Teak

€ 5.075

W1808

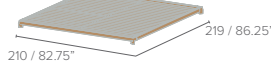

T-Teak

Curtain
Rideau
Gordijn

€ 1.265 Set of 2

P1809-V54



P1809-V64



P1809-V70



Velum:

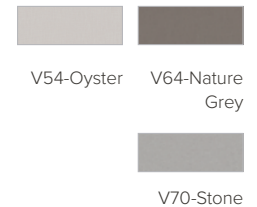

x: colour base
x: couleur base
x: kleur basis

y: colour wall
y: couleur paroi arrière
y: kleur achterwand

z: colour roof
z: couleur toit
z: kleur dak

Cushions, curtains and side table should be ordered separately
Coussins, rideaux et table d'appoint à commander séparément
Kussens, gordijnen en bijzettafel moeten apart besteld worden

Rear wall aluminium

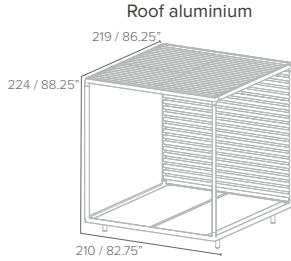

Roof aluminium
01811-x-y-z
Total price: € 13.405
Total price with cushions:
D € 15.845
E € 16.045
F € 16.250
Cover included



Roof movable Sunscape**
01813-x-y-z
Total price: € 12.770
Total price with cushions:
D € 15.210
E € 15.410
F € 15.615
Cover included

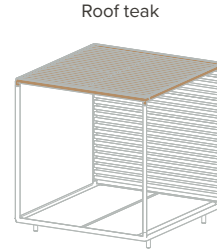

Roof teak
01814-x-y-T
Total price: € 14.045
Total price with cushions:
D € 16.485
E € 16.685
F € 16.890
Cover included

Rear wall Sunscape**

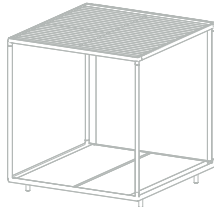

01821-x-y-z
Total price: € 12.770
Total price with cushions:
D € 15.210
E € 15.410
F € 15.615
Cover included

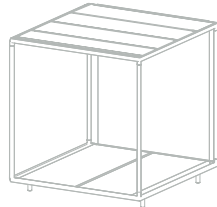

01823-x-y-z
Total price: € 12.130
Total price with cushions:
D € 14.570
E € 14.770
F € 14.975
Cover included

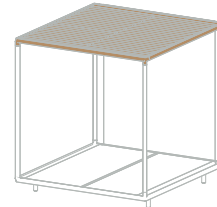

01824-x-y-T
Total price: € 13.405
Total price with cushions:
D € 15.845
E € 16.045
F € 16.250
Cover included

Rear wall teak

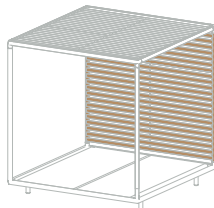

01831-x-T-z
Total price: € 14.045
Total price with cushions:
D € 16.485
E € 16.685
F € 16.890
Cover included

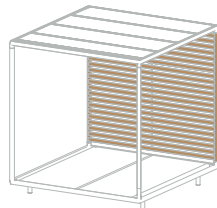

01833-x-T-z
Total price: € 13.405
Total price with cushions:
D € 15.845
E € 16.045
F € 16.250
Cover included

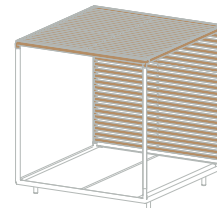

01834-x-T-T
Total price: € 14.685
Total price with cushions:
D € 17.125
E € 17.325
F € 17.530
Cover included

Rear wall empty

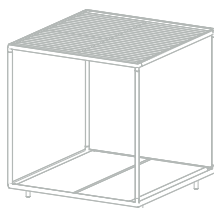

01841-x-y-z
Total price: € 11.490
Total price with cushions:
D € 13.930
E € 14.130
F € 14.335
Cover included

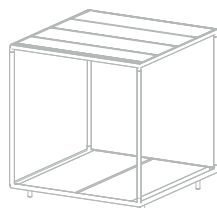

01843-x-y-z
Total price: € 10.855
Total price with cushions:
D € 13.295
E € 13.495
F € 13.700
Cover included

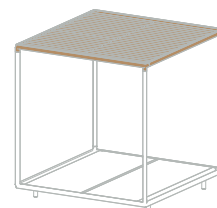

01844-x-y-T
Total price: € 12.130
Total price with cushions:
D € 14.570
E € 14.770
F € 14.975
Cover included

** Possible colour combinations, see p. 62-63

** Pour des combinaisons de couleurs possible, voir p. 62-63

** Voor mogelijke kleurcombinaties, zie p. 62-63

Plantation teak from Java
Teck de plantation de Java
Plantageteak uit Java

Roof in Sunscape
Toit en Sunscape
Dak in Sunscape

Curtains in Sunbrella Velum
Rideaux en Sunbrella Velum
Gordijnen in Sunbrella Velum

Cushions and curtains should be ordered separately
Coussins et rideaux à commander séparément
Kussens en gordijnen moeten apart besteld worden

Cabana daybed
Lit de jour Cabana
Cabana daybed

€ 12.750



D1249C
Cover*
Housse*
Hoes*
€ 385

C01249SETW
Cushion Set
Coussin Set
Kussen Set

D € 3.735
E € 4.285
F € 4.935

*Cover: covers the cushions only and is included in the article ref. and the price of the daybed.
*Housse: couvre seulement les coussins et est inclus dans le code article et le prix du lit de jour.
*Hoes: bedekt enkel de kussens en is inbegrepen in de artikelcode en de prijs van het daybed

Curtain
Rideau
Gordijn

€ 1.265 Set of 2

P1209-V54



P1209-V64



P1209-V70



Velum:

V54-Oyster V64-Nature Grey V70-Stone



Plantation teak from Java
Teck de plantation de Java
Plantageteak uit Java

C-table
Table-C
C-tafel

€ 900

Teak



D6123

Cover
Housse
Hoes

€ 125



Lounger
Chaise longue
Ligbed



€ 2.040

D1242
Cover
Housse
Hoes
€ 285

C01242W
Cushion
Coussin
Kussen

D € 1.865

E € 2.140

F € 2.470



Lounger
Chaise longue
Ligbed



€ 2.295

01243 - with wheels*

€ 2.250

01244 - with legs

D1242
Cover
Housse
Hoes
€ 285

C01242W
Cushion
Coussin
Kussen

D € 1.865

E € 2.140

F € 2.470



C01242W
Cushion
Coussin
Kussen

D € 1.865

E € 2.140

F € 2.470



* The lounger is equipped with wheels positioned on the inside, allowing easy mobility.

* La chaise longue est équipée de roues placées à l'intérieur, ce qui permet de la déplacer facilement.





* Het ligbed heeft wieltes aan de binnenkant, waardoor het gemakkelijk te verplaatsen is.

PURE SOFA

ANDREI MUNTEANU

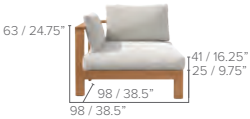
Plantation teak from Java
Teck de plantation de Java
Plantageteak uit Java

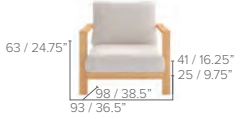
Extra soft filling (Seat + back + armrests cushions)
Rembourrage particulièrement doux (Coussin d'assise + dossier + bras)
Extra zachte vulling (Zit + rugkussens + armsteun)

	 <p>Corner sofa</p> <p>63 / 24.75" 41 / 16.25" 25 / 9.75" 98 / 38.5"</p>	 <p>Corner sofa + corner cushion</p> <p>41 / 16.25"</p>	 <p>Armchair</p> <p>63 / 24.75" 41 / 16.25" 25 / 9.75" 98 / 38.5" 93 / 36.5"</p>	<p>Extra back cushion Coussin supplémentaire Extra rugkussen 75.5x48x5cm</p>
Frame	01201 € 1.725	01201 € 1.725	01202s € 1.740	C01201BCAW D € 370 E € 390 F € 425
Cushion	C01201CAW D € 1.825 E € 2.030 F € 2.230	C01211CAW D € 1.875 E € 2.140 F € 2.450	C01202sCAW D € 1.430 E € 1.620 F € 1.795	
Cover	D6008C € 260	D1211 € 260	D6050C € 305	

	 <p>Right arm sofa</p> <p>193 / 76" 98 / 38.5" 25 / 9.75"</p>	 <p>Right arm sofa + corner cushion</p>	 <p>Extension Double</p> <p>63 / 24.75" 41 / 16.25" 25 / 9.75" 185 / 72.75" 98 / 38.5"</p>	<p>Corner Back Only C01204BCAW D € 825 E € 955 F € 1.110</p> 
Frame	01204 € 2.540	01204 € 2.540	01228 € 2.340	
Cushion	C01205CAW D € 3.510 E € 3.930 F € 4.360	C01215CAW D € 3.560 E € 4.040 F € 4.580	C01228CAW D € 3.130 E € 3.510 F € 3.925	Right/Left Arm Back Only C01212BCAW
Cover	D6007RC € 385	D1215R € 385	D1228 € 380	D € 405 E € 455 F € 505

	 <p>Left arm sofa</p> <p>63 / 24.75" 41 / 16.25" 25 / 9.75" 193 / 76" 98 / 38.5"</p>	 <p>Left arm sofa + corner cushion</p>
Frame	01203 € 2.540	01203 € 2.540
Cushion	C01205CAW D € 3.510 E € 3.930 F € 4.360	C01215CAW D € 3.560 E € 4.040 F € 4.580
Cover	D6007LC € 385	D1215L € 385

	 <p>2-Seater sofa</p> <p>63 / 24.75" 41 / 16.25" 25 / 9.75" 200 / 78.75" 98 / 38.5"</p>	 <p>2-Seater sofa + corner cushion</p>	<p>2-Seater Back Only C01213BCAW D € 450 E € 505 F € 560</p> 	<p>Corner Back - Left Arm Only C01208BCAW D € 880 E € 1.020 F € 1.195</p>
Frame	01207 € 2.695	01207 € 2.695		Corner Back - Right Arm Only C01209BCAW
Cushion	C01206CAW D € 3.445 E € 3.895 F € 4.305	C01216CAW D € 3.545 E € 4.115 F € 4.745		D € 880 E € 1.020 F € 1.195
Cover	D6049C € 440	D1216 € 440		

OPTIONAL

Set of 2 connectors
Set de 2 connecteurs
Set van 2 verbindingsstukken

R0022

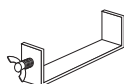

€ 34

C01200CAW
Optional lumbar/Armrest cushion D € 270
Coussin lombaire optionnel E € 320
Optioneel lendekussen F € 360



Combination examples
Exemples de combinaisons
Combinatievoorbeelden

Custom covers = 165€, per single seat and 330€ for meridienne and daybed modules
Housses sur mesure = 165€ par siège simple et 330€ pour les modules méridienne et daybed
Covers op maat = 165€ per enkele zitplaats en 330€ voor meridienne en daybed modules

 = CORNER CUSHION

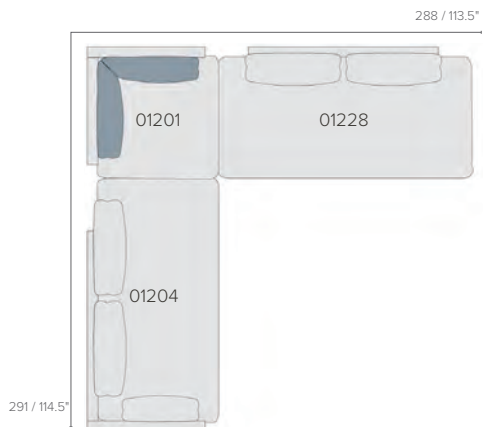

SET 1
frame: 1x 01204 - 1x 01201 - 1x 01228
cushions: C01205CAW + C01211CAW + C01228CAW
connectors: 2x

total price with cushions: Cat. D € 15.188 E € 16.253 F € 17.408
cover: D1301C € 825

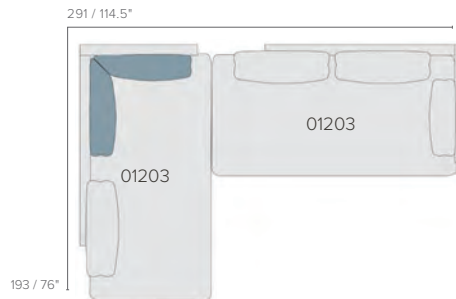

SET 2
frame: 2x 01203
cushions: C01215CAW + C01205CAW
connectors: 1x

total price with cushions: Cat. D € 12.184 E € 13.084 F € 14.054
cover: D1302C € 660

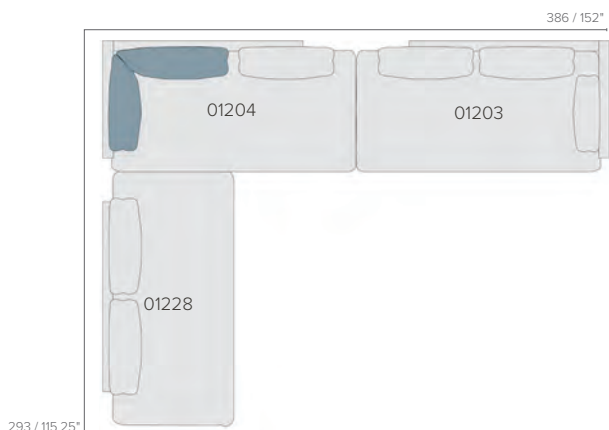

SET 3
frame: 1x 01228 - 1x 01204 - 1x 01203
cushions: C01228CAW + C01215CAW + C01205CAW
connectors: 2x

total price with cushions: Cat. D € 17.688 E € 18.968 F € 20.353
cover: D1303C € 990

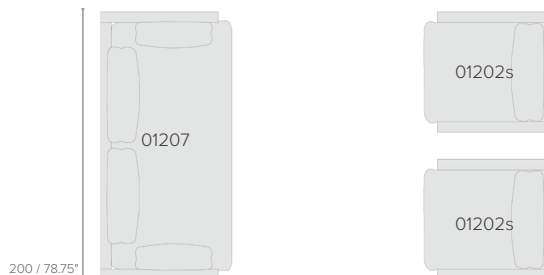

SET 4
frame: 1x 01207 - 2x 01202s
cushions: C01206CAW + 2x C01202sCAW

total price with cushions: Cat. D € 12.480 E € 13.310 F € 14.070
covers: 1x D6049C + 2x D6050C = € 440 + 2x € 305 = 1.050 €

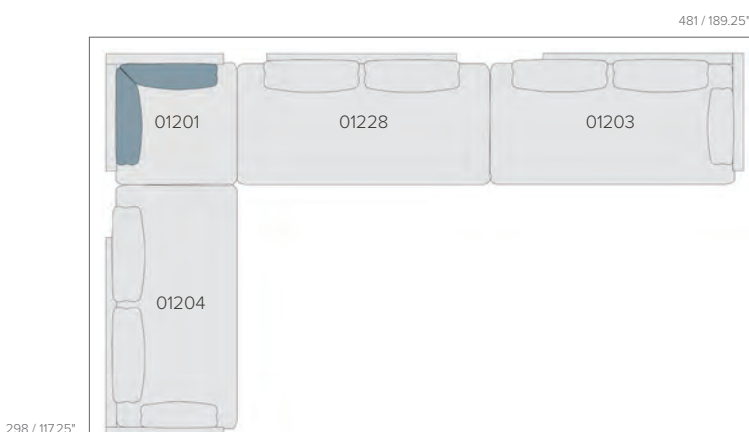

SET 5
frame: 1x 01204 - 1x 01201 - 1x 01228 - 1x 01203
cushions: 2x C01205CAW + C01211CAW + C01228CAW
connectors: 3x

total price with cushions: Cat. D € 21.272 E € 22.757 F € 24.342
covers: D1305C € 1.155

PURE SETS

Custom covers = 165€ per single seat and 330€ for meridienne and daybed modules
 Housses sur mesure = 165€ par siège simple et 330€ pour les modules méridienne et daybed
 Covers op maat = 165€ per enkele zitplaats en 330€ voor meridienne en daybed modules

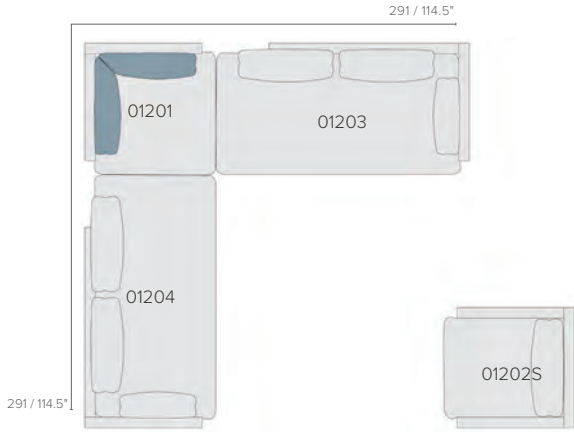

SET 8

frame: 1x 01204 - 1x 01203 - 1x 01201 - 1x 01202s
 cushions: 2x C01205CAW + C01211CAW + C01202sCAW
 connectors: 2x

total price with cushions: Cat. D **€ 18.938** E **€ 20.233** F **€ 21.578**
 covers: 1x D1308C + 1x D6050C = **€ 825 + € 305 = € 1.130**

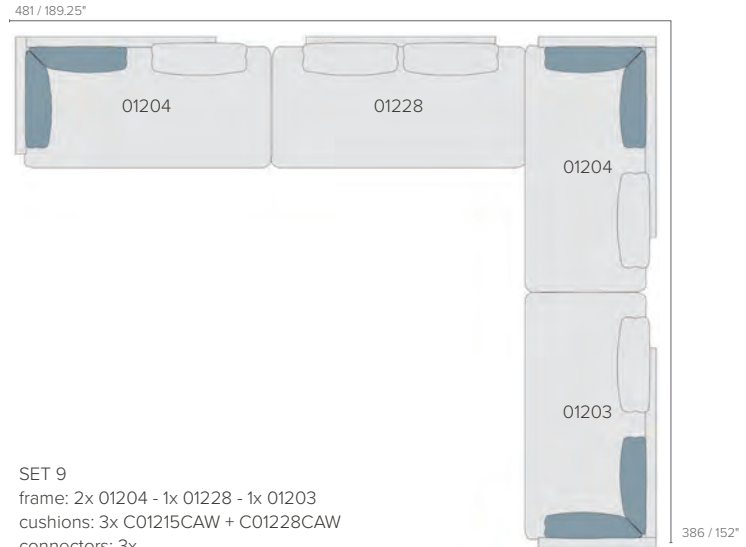

SET 9

frame: 2x 01204 - 1x 01228 - 1x 01203
 cushions: 3x C01215CAW + C01228CAW
 connectors: 3x

total price with cushions: Cat. D **€ 23.872** E **€ 25.692** F **€ 27.727**
 cover: D1309C **€ 1.320**

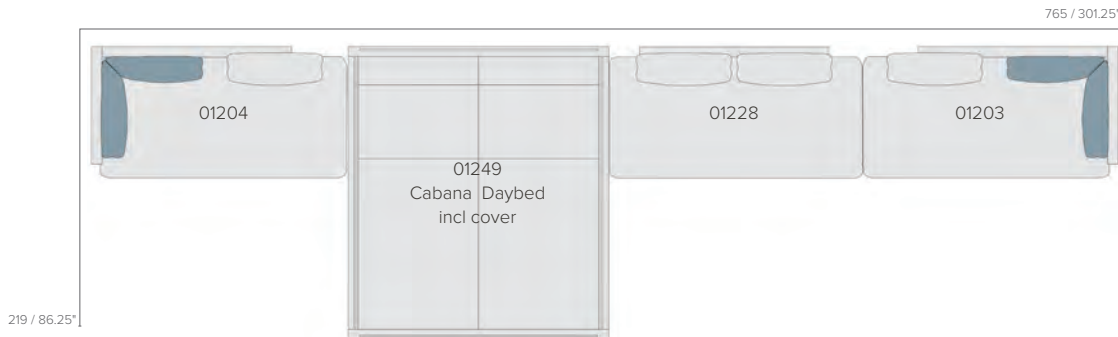

SET 10

frame: 01204 - 01249 - 01228 - 01203
 cushions: 2x C01215CAW + C01249SETW + C01228CAW
 connectors: 3x

total price with cushions: Cat. D **€ 34.257** E **€ 36.147** F **€ 38.292**
 cover: 1x D1215R + D1310C = **€ 385 + € 660 = € 1.045**

SET 12

frame: 2x 01204 - 1x 01244
 cushions: 2x C01215CAW + C01242W
 connectors: 2x

total price with cushions: Cat. D **€ 16.383** E **€ 17.618** F **€ 19.028**
 cover: D1312C **€ 945**



CANAX
10-Linen

10-Linen 89-Wengé T-Teak
LEGS
FRAME
10-Linen 89-Wengé

Powdercoated aluminium
Aluminium peint par poudrage
Gepoedercoat aluminium

Legs: powdercoated aluminium or teak (set of 4)
Pieds: alu peint par poudrage ou teck (set de 4)
Poten: gepoedercoat alu of teak (set van 4)

Canax®
Canax®
Canax®

Armchair
Fauteuil repas
Armstoel

€ 995



D2318
Cover
Housse
Hoes
€ 215

C02318BW
Back cushion
Coussin dossier
Rugkussen
D € 175
E € 210
F € 255

C02318SW
Seat cushion
Coussin d'assise
Zitkussen
D € 300
E € 340
F € 360



C0001PW
Back cushion with piping
Coussin dossier passepoil
Rugkussen met bies
D € 155
E € 185
F € 210

C02318SW
Seat cushion
Coussin d'assise
Zitkussen
D € 300
E € 340
F € 360



Piping colours see page 115
Couleurs passepoil voir page 115
Bieskleuren zie pagina 115

Lounge chair
Fauteuil
Lage Stoel

€ 1.295

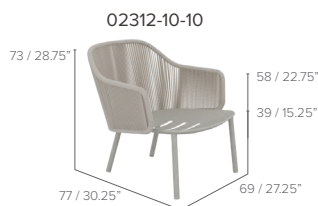

D2316
Cover
Housse
Hoes
€ 215

C02312BW
Back cushion
Coussin dossier
Rugkussen
D € 290
E € 320
F € 365

C02312SW
Seat cushion
Coussin d'assise
Zitkussen
D € 340
E € 370
F € 400



Powdercoated aluminium
Aluminium peint par poudrage
Gepoedercoat aluminium

Seat: Batyline®
Siège: Batyline®
Zit: Batyline®

Adjustable lounger
Chaise longue réglable
Ligbed, verstelbaar

02340-10

02340-89

€ 2.190



D2340
Cover
Housse
Hoes
€ 240

C02340W
Cushion
Coussin
Kussen

D € 1.510
E € 1.695
F € 1.900



Lounger with teak table top
Chaise longue avec dessus de table teck
Ligbed met teak tafelblad

02341-10

02341-89

€ 2.830



D2341
Cover with table top
Housse avec dessus
de table
Hoes met tafelblad
€ 300

C02340W
Cushion
Coussin
Kussen

D € 1.510
E € 1.695
F € 1.900



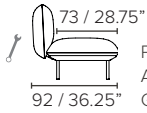
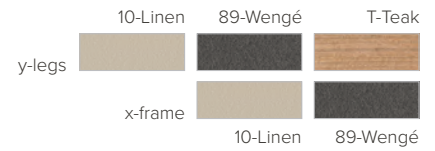





Powdercoated aluminium
Aluminium peint par poudrage
Gepoedercoat aluminium



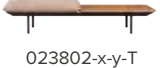

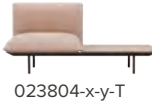

Legs: powdercoated aluminium or teak (set of 4)
Pieds: alu peint par poudrage ou teck (set de 4)
Poten: gepoedercoat alu of teak (set van 4)





Casual back cushions (C02300W) recommended for optimal comfort
Coussins de dos Casual (C02300W) recommandés pour un confort optimal
Casual rugkussens (C02300W) aanbevolen voor optimaal comfort



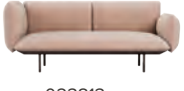

	Pouf module	Single module	1-Seater sofa arm high	1-Seater sofa arm low	Coffee table teak	Coffee table Lava stone
Frame	 023200-x-y € 845	 023201-x-y € 1.145	 023202-x-y € 1.735	 023203-x-y € 1.695	 023204-x-y-T € 1.780	 023205-x-y-Lx € 3.845
Cushion	C023200W D € 780 E € 885 F € 975	C023201W D € 1.520 E € 1.715 F € 1.900	C023202W D € 2.840 E € 3.195 F € 3.510	C023203W D € 2.660 E € 2.945 F € 3.210		
Cover	D23200 € 135	D23201 € 190	D23202 € 280	D23203 € 275	D23204 € 130	D23204 € 130

	Double pouf module	Pouf + teak table*	Single module + pouf*	Single module + teak table*	Double module
Frame	 023801-x-y € 1.100	 023802-x-y-T € 2.035	 023803-x-y € 1.400	 023804-x-y-T € 2.335	 023805-x-y € 1.700
Cushion	C023801W D € 1.300 E € 1.505 F € 1.680	C023802W D € 780 E € 885 F € 975	C023803W D € 2.305 E € 2.605 F € 2.875	C023804W D € 1.520 E € 1.730 F € 1.900	C023805W D € 2.800 E € 3.195 F € 3.535
Cover	D23801 € 250	D23802 € 250	D23803 € 260	D23804 € 260	D23805 € 290

*This module can also be mirrored
*Ce module peut également être mis en miroir
*Deze module kan ook gespiegeld worden

	Right corner arm high	Left corner arm high	Right corner arm low	Left corner arm low	2-Seater arm high	2-Seater arm low
Frame	 023806-x-y € 1.995	 023807-x-y € 1.995	 023808-x-y € 1.975	 023809-x-y € 1.975	 023810-x-y € 2.290	 023811-x-y € 2.250
Cushion	C023806W D € 3.460 E € 3.935 F € 4.340	C023807W D € 3.460 E € 3.935 F € 4.340	C023808W D € 3.370 E € 3.810 F € 4.190	C023809W D € 3.370 E € 3.810 F € 4.190	C023810W D € 4.120 E € 4.675 F € 5.145	C023811W D € 3.940 E € 4.425 F € 4.845
Cover	D23806 € 320	D23807 € 320	D23808 € 315	D23809 € 315	D23810 € 330	D23811 € 340

	2-Seater right arm low	2-Seater left arm low	Right corner arm high + pouf	Left corner arm high + pouf	Right corner arm low + pouf	Left corner arm low + pouf
Frame	 023812-x-y € 2.270	 023813-x-y € 2.270	 023814-x-y € 1.695	 023815-x-y € 1.695	 023816-x-y € 1.675	 023817-x-y € 1.675
Cushion	C023812W D € 4.030 E € 4.550 F € 4.995	C023813W D € 4.030 E € 4.550 F € 4.995	C023814W D € 2.965 E € 3.345 F € 3.680	C023815W D € 2.965 E € 3.345 F € 3.680	C023816W D € 2.875 E € 3.220 F € 3.620	C023817W D € 2.875 E € 3.220 F € 3.620
Cover	D23812 € 315	D23813 € 315	D23814 € 300	D23815 € 300	D23816 € 290	D23817 € 290

	Right corner arm high + teak table	Left corner arm high + teak table	Right corner arm low + teak table	Left corner arm low + teak table	Right corner back low + pouf	Left corner back low + pouf
Frame	 023818-x-y-T € 2.630	 023819-x-y-T € 2.630	 023820-x-y-T € 2.610	 023821-x-y-T € 2.610	 023822-x-y € 1.690	 023823-x-y € 1.690
Cushion	C023818W D € 2.180 E € 2.470 F € 2.705	C023819W D € 2.180 E € 2.470 F € 2.705	C023820W D € 2.090 E € 2.345 F € 2.555	C023821W D € 2.090 E € 2.345 F € 2.555	C023822W D € 2.525 E € 2.800 F € 3.050	C023823W D € 2.525 E € 2.800 F € 3.050
Cover	D23818 € 300	D23819 € 300	D23820 € 290	D23821 € 290	D23822 € 290	D23823 € 290

SENJA SOFA REGULAR

STUDIO SEGERS

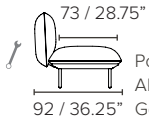
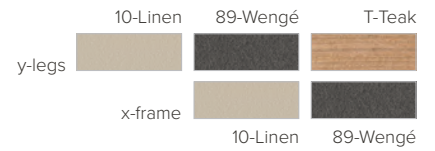

Powdercoated aluminium
Aluminium peint par poudrage
Gepoedercoat aluminium

Legs: powdercoated aluminium or teak (set of 4)
Pieds: alu peint par poudrage ou teck (set de 4)
Poten: gepoedercoat alu of teak (set van 4)

Casual back cushions (C02300W) recommended for optimal comfort
Coussins de dos Casual (C02300W) recommandés pour un confort optimal
Casual rugkussens (C02300W) aanbevolen voor optimaal comfort

Triple pouf module

Triple module

3-Seater arm high

3-Seater arm low

3-Seater right arm low

					
Frame	023901-x-y € 1.460	023902-x-y € 2.360	023903-x-y € 2.950	023904-x-y € 2.910	023905-x-y € 2.930
Cushion	C023901W D € 1.810 E € 2.100 F € 2.340	C023902W D € 4.065 E € 4.635 F € 5.125	C023903W D € 5.385 E € 6.115 F € 6.735	C023904W D € 5.205 E € 5.865 F € 6.435	C023905W D € 5.295 E € 5.990 F € 6.585
Cover	D23901 € 365	D23902 € 425	D23903 € 485	D23904 € 490	D23905 € 495





3-Seater left arm low

Right extension + pouf

Left extension + pouf

Right extension + teak table

Left extension + teak table

					
Frame	023906-x-y € 2.930	023907-x-y € 2.060	023908-x-y € 2.060	023909-x-y-T € 2.995	023910-x-y-T € 2.995
Cushion	C023906W D € 5.295 E € 5.990 F € 6.585	C023907W D € 3.310 E € 3.785 F € 4.205	C023908W D € 3.310 E € 3.785 F € 4.205	C023909W D € 2.800 E € 3.195 F € 3.535	C023910W D € 2.800 E € 3.195 F € 3.535
Cover	D23906 € 495	D23907 € 405	D23908 € 405	D23909 € 405	D23910 € 405

Right corner arm high

Left corner arm high

Right corner arm low

Left corner arm low

				
Frame	023911-x-y € 2.655	023912-x-y € 2.655	023913-x-y € 2.635	023914-x-y € 2.635
Cushion	C023911W D € 4.725 E € 5.375 F € 5.930	C023912W D € 4.725 E € 5.375 F € 5.930	C023913W D € 4.635 E € 5.250 F € 5.780	C023914W D € 4.635 E € 5.250 F € 5.780
Cover	D23911 € 470	D23912 € 470	D23913 € 465	D23914 € 465

Right corner arm high + pouf

Left corner arm high + pouf

Right corner arm low + pouf

Left corner arm low + pouf

				
Frame	023915-x-y € 2.355	023916-x-y € 2.355	023917-x-y € 2.335	023918-x-y € 2.335
Cushion	C023915W D € 3.970 E € 4.525 F € 5.010	C023916W D € 3.970 E € 4.525 F € 5.010	C023917W D € 3.880 E € 4.400 F € 4.860	C023918W D € 3.880 E € 4.400 F € 4.860
Cover	D23915 € 430	D23916 € 430	D23917 € 425	D23918 € 425

Right corner arm high + teak table

Left corner arm high + teak table

Right corner arm low + teak table

Left corner arm low + teak table

				
Frame	023919-x-y-T € 3.290	023920-x-y-T € 3.290	023921-x-y-T € 3.270	023922-x-y-T € 3.270
Cushion	C023919W D € 3.460 E € 3.935 F € 4.340	C023920W D € 3.460 E € 3.935 F € 4.340	C023921W D € 3.370 E € 3.810 F € 4.190	C023922W D € 3.370 E € 3.810 F € 4.190
Cover	D23919 € 430	D23920 € 430	D23921 € 425	D23922 € 425

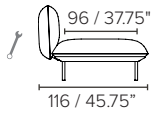
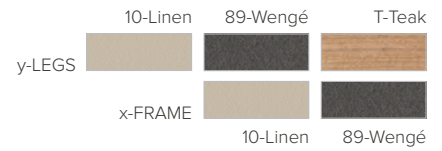

Powdercoated aluminium
Aluminium peint par poudrage
Gepoedercoat aluminium

Legs: powdercoated aluminium or teak (set of 4)
Pieds: alu peint par poudrage ou teck (set de 4)
Poten: gepoedercoat alu of teak (set van 4)

Casual back cushions (C02300W) recommended for optimal comfort
Coussins de dos casual (C02300W) recommandés pour un confort optimal
Casual rugkussens (C02300W) aanbevolen voor optimaal comfort



Double pouf module

Pouf + teak table*

Single module + pouf*

Single module + teak table*

Double module

Frame	 023851-x-y € 1.220	 023852-x-y-T € 2.415	 023853-x-y € 1.520	 023854-x-y-T € 2.715	 023855-x-y € 1.820
Cushion	C023851W D € 1.605 E € 1.800 F € 1.980	C023852W D € 935 E € 1.035 F € 1.130	C023853W D € 2.355 E € 2.650 F € 2.905	C023854W D € 1.685 E € 1.880 F € 2.055	C023855W D € 3.105 E € 3.495 F € 3.835
Cover	D23851 € 290	D23852 € 290	D23853 € 305	D23854 € 305	D23855 € 330

*This module can also be mirrored.
*Ce module peut également être mis en miroir.
*Deze module kan ook gespiegeld worden.

Right corner arm high

Left corner arm high

Right corner arm low

Left corner arm low

2-Seater arm high

2-Seater arm low







Frame	 023856-x-y € 2.130	 023857-x-y € 2.130	 023858-x-y € 2.120	 023859-x-y € 2.120	 023860-x-y € 2.440	 023861-x-y € 2.420
Cushion	C023856W D € 3.885 E € 4.385 F € 4.820	C023857W D € 3.885 E € 4.385 F € 4.820	C023858W D € 3.775 E € 4.225 F € 4.625	C023859W D € 3.775 E € 4.225 F € 4.625	C023860W D € 4.665 E € 5.275 F € 5.805	C023861W D € 4.445 E € 4.955 F € 5.415
Cover	D23856 € 370	D23857 € 370	D23858 € 365	D23859 € 365	D23860 € 380	D23861 € 385

2-Seater right arm low

2-Seater left arm low

Right corner arm high + pouf Left corner arm high + pouf

Right corner arm low + pouf Left corner arm low + pouf

Frame	 023862-x-y € 2.430	 023863-x-y € 2.430	 023864-x-y € 1.830	 023865-x-y € 1.830	 023866-x-y € 1.820	 023867-x-y € 1.820
Cushion	C023862W D € 4.555 E € 4.955 F € 5.415	C023863W D € 4.555 E € 4.955 F € 5.415	C023864W D € 3.135 E € 3.540 F € 3.890	C023865W D € 3.135 E € 3.540 F € 3.890	C023866W D € 3.025 E € 3.380 F € 3.695	C023867W D € 3.025 E € 3.380 F € 3.695
Cover	D23862 € 365	D23863 € 365	D23864 € 345	D23865 € 345	D23866 € 330	D23867 € 330

Right corner arm high + teak table

Left corner arm high + teak table

Right corner arm low + teak table

Left corner arm low + teak table

Frame	 023868-x-y-T € 3.025	 023869-x-y-T € 3.025	 023870-x-y-T € 3.015	 023871-x-y-T € 3.015
Cushion	C023868W D € 2.465 E € 2.770 F € 3.010	C023869W D € 2.465 E € 2.770 F € 3.010	C023870W D € 2.355 E € 2.610 F € 2.845	C023871W D € 2.355 E € 2.610 F € 2.845
Cover	D23868 € 340	D23869 € 340	D23870 € 330	D23871 € 330

SENJA SOFA DEEP STUDIO SEGERS

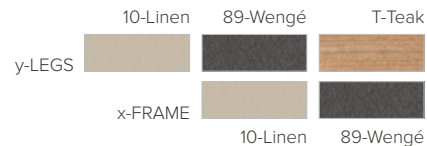

75

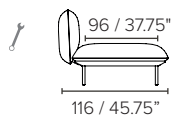

Powdercoated aluminium
Aluminium peint par poudrage
Gepoedercoat aluminium

Legs: powdercoated aluminium or teak (set of 4)
Pieds: alu peint par poudrage ou teck (set de 4)
Poten: gepoedercoat alu of teak (set van 4)

Casual back cushions (C02300W) recommended for optimal comfort
Coussins de dos casual (C02300W) recommandés pour un confort optimal
Casual rugkussens (C02300W) aanbevolen voor optimaal comfort





Triple pouf module

Triple module

3-Seater arm high

3-Seater arm low

3-Seater right arm low

Frame	 023951-x-y € 1.620	 023952-x-y € 2.520	 023953-x-y € 3.140	 023954-x-y € 3.120	 023955-x-y € 3.130
Cushion	C023951W D € 2.235 E € 2.515 F € 2.755	C023952W D € 4.480 E € 5.050 F € 5.535	C023953W D € 6.040 E € 6.820 F € 7.515	C023954W D € 5.840 E € 6.510 F € 7.115	C023955W D € 5.940 E € 6.665 F € 7.315
Cover	D23951 € 420	D23952 € 485	D23953 € 555	D23954 € 565	D23955 € 570





3-Seater left arm low

Right extension + pouf

Left extension + pouf

Right extension + teak table

Left extension + teak table

Frame	 023956-x-y € 3.130	 023957-x-y € 2.220	 023958-x-y € 2.220	 023959-x-y-T € 3.415	 023960-x-y-T € 3.415
Cushion	C023956W D € 5.940 E € 6.665 F € 7.315	C023957W D € 3.735 E € 4.205 F € 4.615	C023958W D € 3.735 E € 4.205 F € 4.615	C023959W D € 3.105 E € 3.495 F € 3.835	C023960W D € 3.105 E € 3.495 F € 3.835
Cover	D23956 € 570	D23957 € 465	D23958 € 465	D23959 € 465	D23960 € 465

Right corner arm high

Left corner arm high

Right corner arm low

Left corner arm low



Frame	 023961-x-y € 2.830	 023962-x-y € 2.830	 023963-x-y € 2.820	 023964-x-y € 2.820
Cushion	C023961W D € 5.260 E € 5.935 F € 6.525	C023962W D € 5.260 E € 5.935 F € 6.525	C023963W D € 5.160 E € 5.780 F € 6.325	C023964W D € 5.160 E € 5.780 F € 6.325
Cover	D23961 € 540	D23962 € 540	D23963 € 530	D23964 € 530

Right corner arm high + pouf

Left corner arm high + pouf

Right corner arm low + pouf

Left corner arm low + pouf





Frame	 023965-x-y € 2.530	 023966-x-y € 2.530	 023967-x-y € 2.520	 023968-x-y € 2.520
Cushion	C023965W D € 4.515 E € 5.090 F € 5.605	C023966W D € 4.515 E € 5.090 F € 5.605	C023967W D € 4.415 E € 4.935 F € 5.405	C023968W D € 4.415 E € 4.935 F € 5.405
Cover	D23965 € 490	D23966 € 490	D23967 € 485	D23968 € 485

Right corner arm high + teak table

Left corner arm high + teak table

Right corner arm low + teak table

Left corner arm low + teak table

Frame	 023969-x-y-T € 3.725	 023970-x-y-T € 3.725	 023971-x-y-T € 3.715	 023972-x-y-T € 3.715
Cushion	C023969W D € 3.885 E € 4.380 F € 4.825	C023970W D € 3.885 E € 4.380 F € 4.825	C023971W D € 3.785 E € 4.225 F € 4.625	C023972W D € 3.785 E € 4.225 F € 4.625
Cover	D23969 € 490	D23970 € 490	D23971 € 485	D23972 € 485

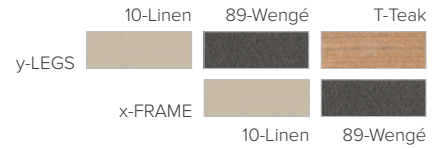

NEW

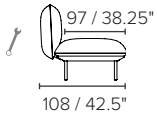

Powdercoated aluminium
Aluminium peint par poudrage
Gepoedercoat aluminium

Legs: powdercoated alu or teak (set of 4)
Pieds: aluminium ou teck (set de 4)
Poten: gepoedercoat alu of teak (set van 4)

Casual back cushions (C02300W) recommended for optimal comfort
Coussins de dos Casual (C02300W) recommandés pour un confort optimal
Casual rugkussens (C02300W) aanbevolen voor optimaal comfort

	Pouf module	Single module*	Double module
Frame	023500-x-y € 1.180	023501-x-y € 1.480	023502-x-y € 1.780
Cushion	C023500W D € 1.370 E € 1.580 F € 1.790	C023501W D € 2.030 E € 2.375 F € 2.710	C023502W D € 2.690 E € 3.170 F € 3.630
Cover	D23500 € 310	D23501 € 325	D23502 € 350

*This module can also be mirrored.
*Ce module peut également être mis en miroir.
*Deze module kan ook gespiegeld worden.

	Right corner arm high	Left corner arm high	Right corner arm low	Left corner arm low
Frame	023503-x-y € 2.075	023504-x-y € 2.075	023505-x-y € 2.055	023506-x-y € 2.055
Cushion	C023503W D € 3.260 E € 3.855 F € 4.425	C023504W D € 3.260 E € 3.855 F € 4.425	C023505W D € 3.175 E € 3.730 F € 4.260	C023506W D € 3.175 E € 3.730 F € 4.260
Cover	D23503 € 390	D23504 € 390	D23505 € 375	D23506 € 375

	2-Arm - arm high	2-Arm - arm low
Frame	023507-x-y € 2.370	023508-x-y € 2.330
Cushion	C023507W D € 3.830 E € 4.540 F € 5.220	C023508W D € 3.660 E € 4.290 F € 4.890
Cover	D23507 € 410	D23508 € 405

SENJA SOFA MERIDIENNE STUDIO SEGERS

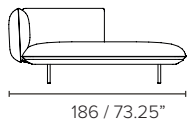
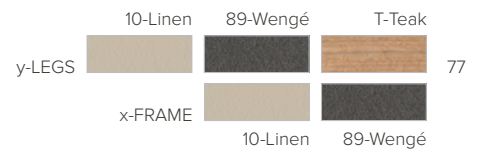

Powdercoated aluminium / Aluminium peint par poudre / Gepoedercoat aluminium
 Legs: powdercoated alu or teak (set of 4) / Pieds: aluminium ou teck (set de 4) / Poten: gepoedercoat alu of teak (set van 4)
 Casual back cushions (C02300W) recommended for optimal comfort / Coussins de dos Casual (C02300W) recommandés pour un confort optimal / Casual rugkussens (C02300W) aanbevolen voor optimaal comfort

	Meridienne left arm high	Meridienne left arm low	Meridienne right arm high	Meridienne right arm low	Meridienne daybed
Frame	023301-x-y € 1.830	023302-x-y € 1.825	023401-x-y € 1.830	023402-x-y € 1.825	023403-x-y € 1.530
Cushion	C023301W D € 3.135 E € 3.540 F € 3.890	C023302W D € 3.025 E € 3.380 F € 3.700	C023401W D € 3.135 E € 3.540 F € 3.890	C023402W D € 3.025 E € 3.380 F € 3.700	C023403W D € 2.355 E € 2.655 F € 2.925
Cover	D23301 € 340	D23302 € 350	D23401 € 340	D23402 € 350	D23403 € 315

Casual back cushion
 Coussin dossier Casual
 Casual rugkussen
 68x45x15cm

C02300W



€ 350 Cat D
 € 430 Cat E
 € 480 Cat F

Separate Arm/Backrests
 Dossiers/Accoudoirs séparés
 Aparte Arm/Rugsteunen

Price on request
 Prix sur demande
 Prijs op aanvraag

Console table
 Table de console
 Console tafel

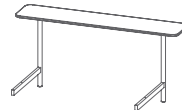
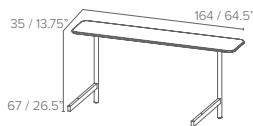
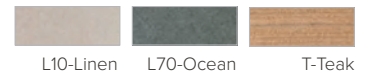

Table: glazed lava stone or teak
 Table: pierre de lave émaillée ou teck
 Tafel: geëmailleerde lavasteen of teak



€ 2.880 Lava stone

02387-10-Lx

02387-89-Lx

€ 1.260 Teak

02387-10-T

02387-89-T

D2387CONSOLE

Cover
 Housse
 Hoes
 € 135

Side table
 Table d'appoint
 Zijtafeltje

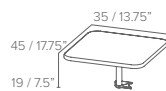

€ 1.445 Lava stone

02381-10-Lx

02381-89-Lx

€ 525 teak

02381-10-T

02381-89-T

D2381SIDE

Cover
 Housse
 Hoes
 € 135

Table top regular
 Dessus de table standard
 Tafelblad standaard



Table: glazed lava stone or teak
 Table: pierre de lave émaillée ou teck
 Tafel: geëmailleerde lavasteen of teak

+€ 2.065 Lava stone

02370S-10-Lx

02370S-89-Lx



Table top deep
 Dessus de table profonde
 Tafelblad diep

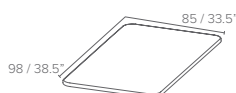

+€ 2.195 Lava stone

02370D-10-Lx

02370D-89-Lx

This is an additional cost versus the price for teak (regular p72-73 & deep p74-75)
 Ceci est un coût supplémentaire vs le prix pour teck (standard p72-73 & profonde p74-75)
 Dit is een bijkomende kost tov de prijs voor teak (regular p72-73 & deep p74-75)

The specified table tops are in teak. For lava stone there is an additional cost.
 Les dessus de table mentionnés sont en teck. Pour la pierre de lave, il y a un supplément.
 De vermelde tafeltops zijn in teak. Voor lavasteen is er een meerkost.

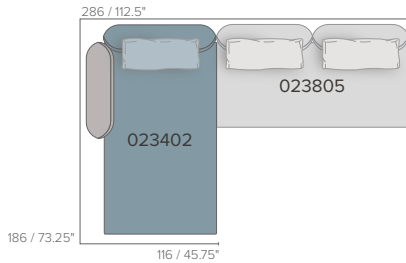
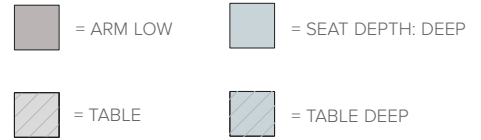

SET 1
 Frame: 023402 + 023805
 Cushions: C023402W + C023805W
 Casual back cushions: 3x C02300W

Total price: Cat. D **€ 10.400** E **€ 11.390** F **€ 12.200**
 Total price without casual back: Cat. D **€ 9.350** E **€ 10.100** F **€ 10.760**
 Cover: D2301 **€ 655**

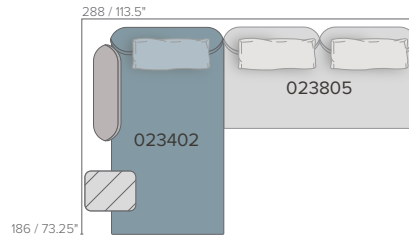

SET 2
 Frame: 023402 + 023805
 Cushions: C023402W + C023805W
 Sidetable: 02381-T
 Casual back cushions: 3x C02300W

Total price: Cat. D **€ 10.925** E **€ 11.915** F **€ 12.725**
 Total price without casual back: Cat. D **€ 9.875** E **€ 10.625** F **€ 11.285**
 Lava stone top **+€ 920**
 Cover: D2302 **€ 655**

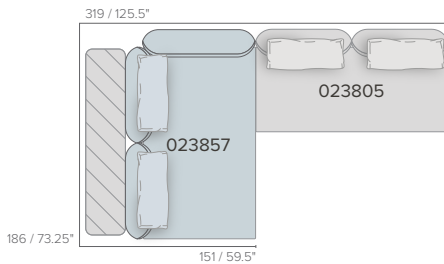

SET 3
 Frame: 023857 + 023805
 Cushions: C023857W + C023805
 Table: 02387-T
 Casual back cushions: 4x C02300W

Total price: Cat. D **€ 13.175** E **€ 14.390** F **€ 15.365**
 Total price without casual back: Cat. D **€ 11.775** E **€ 12.670** F **€ 13.445**
 Lava stone top **+€ 1.620**
 Cover: D2303 **€ 655**

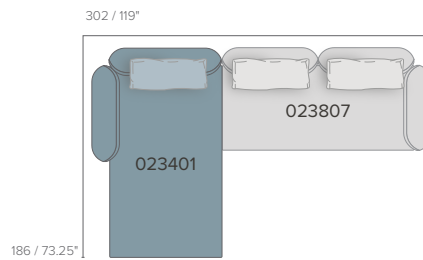

SET 4
 Frame: 023401 + 023807
 Cushions: C023401W + C023807W
 Casual back cushions: 3x C02300W

Total price: Cat. D **€ 11.470** E **€ 12.590** F **€ 13.495**
 Total price without casual back: Cat. D **€ 10.420** E **€ 11.300** F **€ 12.055**
 Cover: D2304 **€ 655**

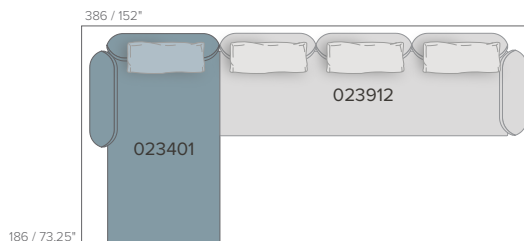

SET 5
 Frame: 023401 + 023912
 Cushions: C023401W + C023912W
 Casual back cushions: 4x C02300W

Total price: Cat. D **€ 13.745** E **€ 15.120** F **€ 16.225**
 Total price without casual back: Cat. D **€ 12.345** E **€ 13.400** F **€ 14.305**
 Cover: D2305 **€ 820**

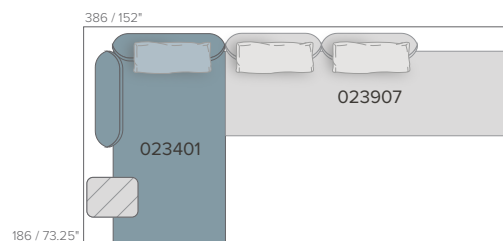

SET 6
 Frame: 023401 + 023907
 Cushions: C023401W + C023907W
 Sidetable: 02381-T
 Casual back cushions: 3x C02300W

Total price: Cat. D **€ 11.910** E **€ 13.030** F **€ 13.950**
 Total price without casual back: Cat. D **€ 10.860** E **€ 11.740** F **€ 12.510**
 Lava stone top **+€ 920**
 Cover: D2306 **€ 820**

Custom covers = 165€ per single seat/table and 330€ for meridienne and daybed modules
 Housses sur mesure = 165€ par siège simple/table et 330€ pour les modules méridienne et daybed
 Covers op maat = 165€ per enkele zitplaats/tafel en 330€ voor meridienne en daybed modules

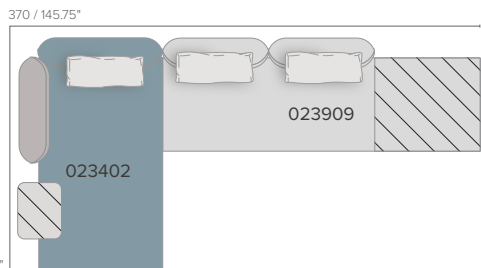
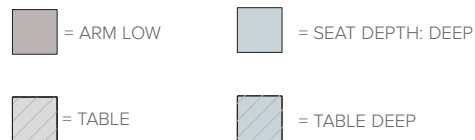

SET 7A
 Frame: 023402 + 023909
 Cushions: C023402W + C023909W
 Sidetable: 02381-T
 Casual back cushions: 3x C02300W

Total price: Cat. D **€ 12.220** E **€ 13.210** F **€ 14.020**
 Total price without casual back: Cat. D **€ 11.170** E **€ 11.920** F **€ 12.580**
 Lava stone top **+€ 2.985**
 Cover: D2323 **€ 820**

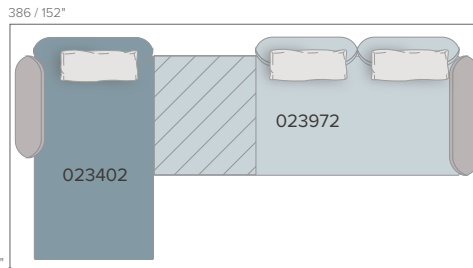

SET 8A
 Frame: 023402 + 023972
 Cushions: C023402W + C023972W
 Casual back cushions: 3x C02300W

Total price: Cat. D **€ 13.400** E **€ 14.435** F **€ 15.305**
 Total price without casual back: Cat. D **€ 12.350** E **€ 13.145** F **€ 13.865**
 Lava stone top **+€ 2.195**
 Cover: D2324 **€ 820**

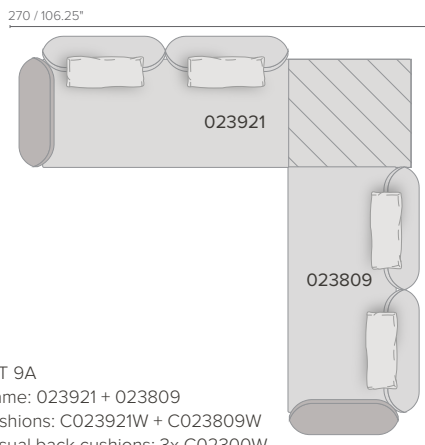

SET 9A
 Frame: 023921 + 023809
 Cushions: C023921W + C023809W
 Casual back cushions: 3x C02300W

Total price: Cat. D **€ 13.385** E **€ 14.585** F **€ 15.545**
 Total price without casual back: Cat. D **€ 11.985** E **€ 12.865** F **€ 13.625**
 Lava stone top **+€ 2.065**
 Cover: D2325 **€ 820**

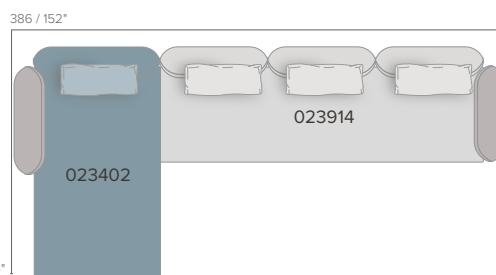

SET 10A
 Frame: 023402 + 023914
 Cushions: C023402W + C023914W
 Casual back cushions: 4x C02300W

Total price: Cat. D **€ 13.520** E **€ 14.810** F **€ 15.860**
 Total price without casual back: Cat. D **€ 12.120** E **€ 13.090** F **€ 13.940**
 Cover: D2326 **€ 820**

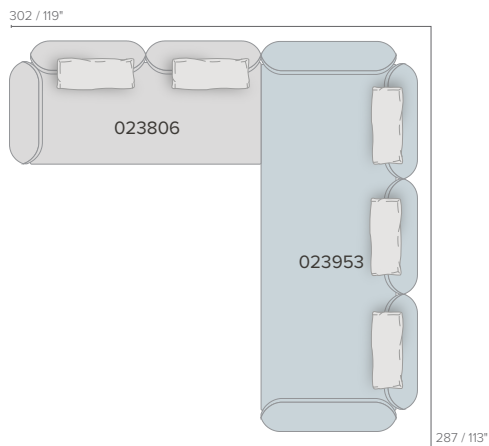

SET 11A
 Frame: 023806 + 023953
 Cushions: C023806W + C023953W
 Casual back cushions: 5x C02300W

Total price: Cat. D **€ 16.385** E **€ 18.040** F **€ 19.390**
 Total price without casual back: Cat. D **€ 14.635** E **€ 15.890** F **€ 16.990**
 Cover: D2327 **€ 820**

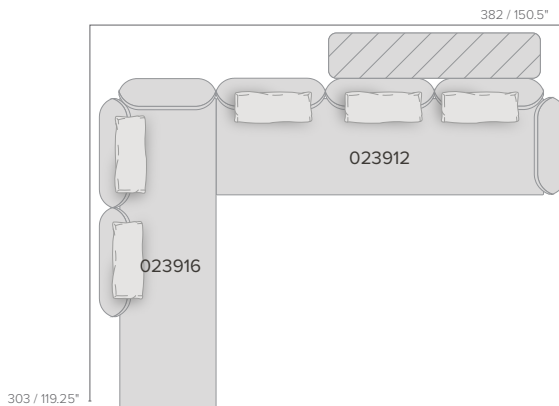

SET 12
 Frame: 023916 + 023912
 Cushions: C023916W + C023912W
 Table: 02387-T
 Casual back cushions: 5x C02300W

Total price: Cat. D **€ 16.715** E **€ 18.320** F **€ 19.610**
 Total price without casual back: Cat. D **€ 14.965** E **€ 16.170** F **€ 17.210**
 Lava stone top **+€ 1.620**
 Cover: D2312 **€ 980**

The table tops mentioned are in teak. For lava stone there is an additional cost.

Les dessus de table mentionnés sont en teck. Pour la pierre de lave, il y a un supplément.

De vermelde tafeltops zijn in teak. Voor lavasteen is er een meerkost.

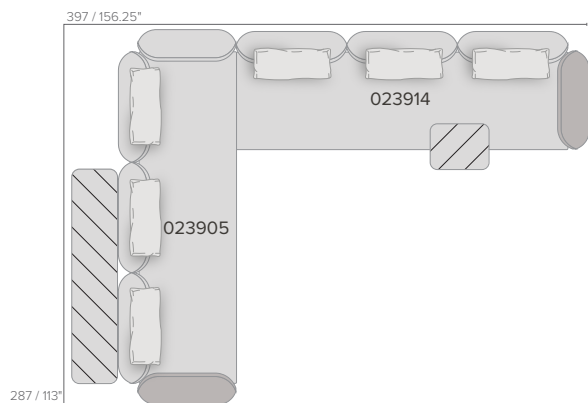
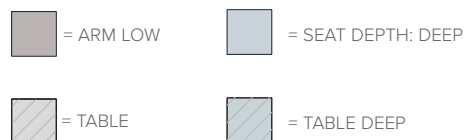

SET 13a

Frame: 023905 + 023914
Cushions: C023905W + C023914W
Sidetables: 02381-T + 02387-T
Casual back cushions: 6x C02300W

Total price: Cat. D € 19.380 E € 21.170 F € 22.595

Total price without casual back: Cat. D € 17.280 E € 18.590 F € 19.715

Lava stone top (2 tables) +€ 2.540

Cover: D2328 € 980

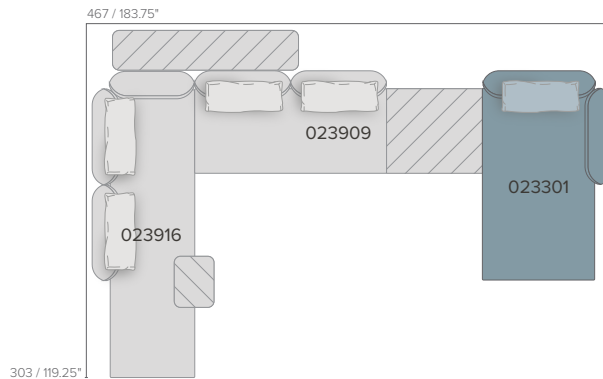

SET 14

Frame: 023916 + 023909 + 023301
Cushions: C023916W + C023909W + C023301W
Tables: 02381-T + 02387-T
Casual back cushions: 5x C02300W

Total price: Cat. D € 20.620 E € 22.375 F € 23.800

Total price without casual back: Cat. D € 18.870 E € 20.225 F € 21.400

Lava stone top (3 tables) +€ 4.605

Cover: D2314 € 1.310

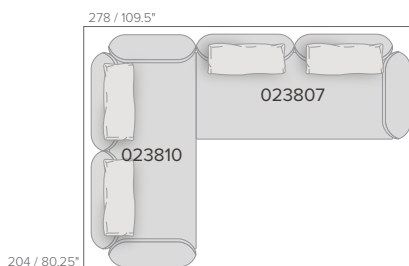

SET 15

Frame: 023810 + 023807
Cushions: C023810W + C023807W
Casual back cushions: 4x C02300W

Total price: Cat. D € 13.265 E € 14.615 F € 15.690

Total price without casual back: Cat. D € 11.865 E € 12.895 F € 13.770

Cover: D2315 € 655

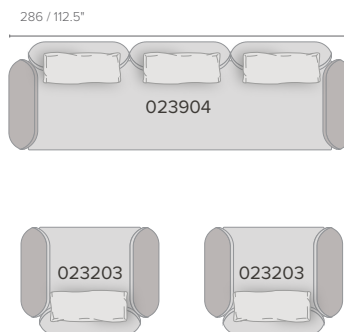

SET 16a

Frame: 023904 + 2x 023203
Cushions: C023904W + 2x C023203W
Casual back cushions: 5x C02300W

Total price: Cat. D € 18.575 E € 20.205 F € 21.555

Total price without casual back: Cat. D € 16.825 E € 18.055 F € 19.155

Cover: D23904 + 2x D23203 € 490 + 2x € 275 = 1.040 €

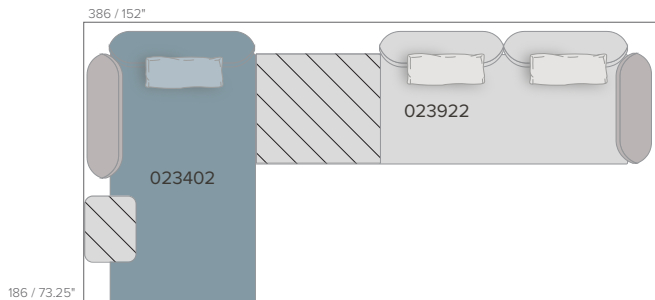

SET 17a

Frame: 023402 + 023922
Cushions: C023402W + C023922W
Sidetables: 02381-T
Casual back cushions: 3x C02300W

Total price: Cat. D € 13.065 E € 14.100 F € 14.950

Total price without casual back: Cat. D € 12.015 E € 12.810 F € 13.510

Lava stone top (2 tables) +€ 2.985

Cover: D2329 € 825

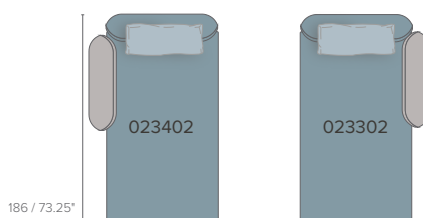

SET 18

Frame: 023402 + 023302
Cushions: C023402W + C023302W
Casual back cushions: 2x C02300W

Total price: Cat. D € 10.400 E € 11.270 F € 12.010

Total price without casual back: Cat. D € 9.700 E € 10.410 F € 11.050

Cover: D23402 + D23302 € 350 + € 350 = 700 €

The table tops mentioned are in teak. For lava stone there is an additional cost.
 Les dessus de table mentionnés sont en teck. Pour la pierre de lave, il y a un supplément.
 De vermelde tafeltops zijn in teak. Voor lavasteen is er een meerkost.

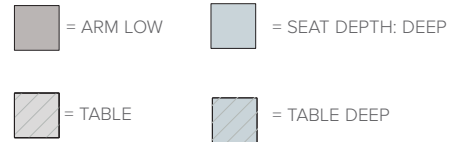

374 / 147.25"

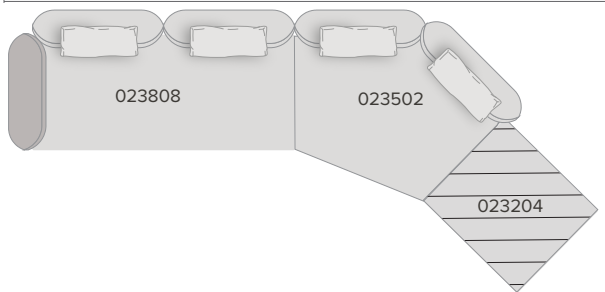

SET 19a
 Frame: 023808 + 023502 + 023204
 Cushions: C023808W + C023502W
 Top options: Teak 023204 | Lavastone 023205
 Casual back cushions: 4x C02300W

Total price Teak top: Cat. D € 12.995 E € 14.235 F € 15.275
 Total price Teak top without casual back: Cat. D € 11.595 E € 12.515 F € 13.355
 Total price Lavastone top: Cat. D € 15.060 E € 16.300 F € 17.340
 Cover: D2330 € 855

462 / 182"

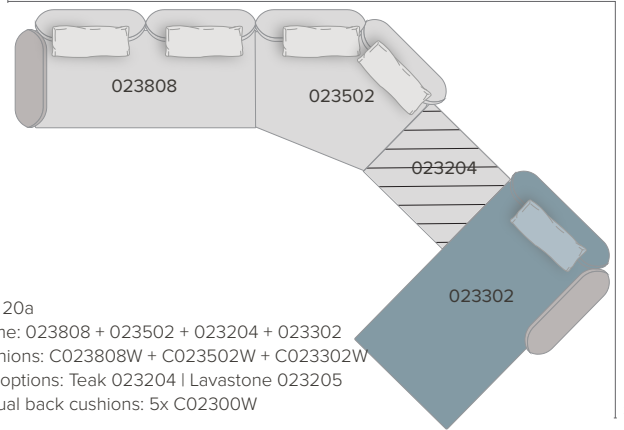

SET 20a
 Frame: 023808 + 023502 + 023204 + 023302
 Cushions: C023808W + C023502W + C023302W
 Top options: Teak 023204 | Lavastone 023205
 Casual back cushions: 5x C02300W

Total price Teak top: Cat. D € 18.195 E € 19.870 F € 21.280
 Total price Teak top without casual back: Cat. D € 16.445 E € 17.720 F € 18.880
 Total price Lavastone top: Cat. D € 20.260 E € 21.935 F € 23.345
 Cover: D2331 € 1.185

318 / 125.25"

403 / 158.75"

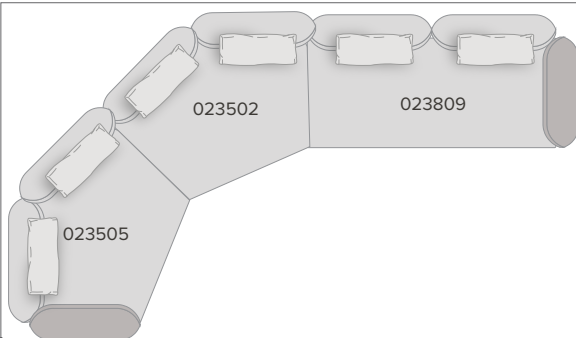

SET 21a
 Frame: 023505 + 023502 + 023809
 Cushions: C023505W + C023502W + C023809W
 Casual back cushions: 6x C02300W

Total price: Cat. D € 17.145 E € 19.100 F € 20.770
 Total price without casual back: Cat. D € 15.045 E € 16.520 F € 17.890
 Cover: D2332 € 1.250

360 / 141.75"

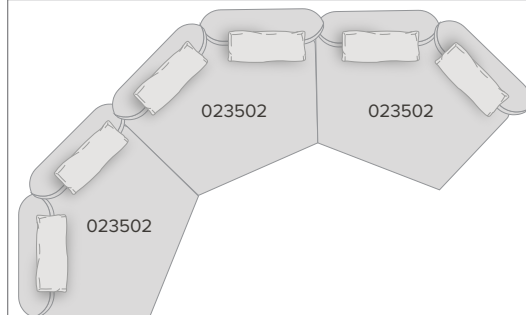

SET 22a
 Frame: 023502 + 023502 + 023502
 Cushions: 3x C023502W
 Casual back cushions: 6x C02300W

Total price: Cat. D € 15.510 E € 17.430 F € 19.110
 Total price without casual back: Cat. D € 13.410 E € 14.850 F € 16.230
 Cover: D2333 € 1.080

214 / 84.25"

458 / 180.25"

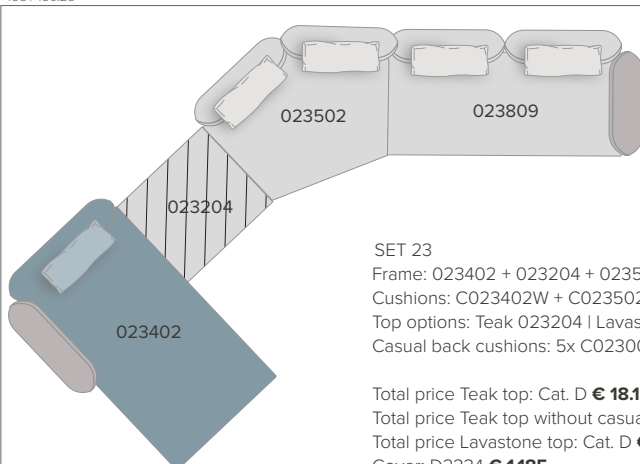

SET 23
 Frame: 023402 + 023204 + 023502 + 023809
 Cushions: C023402W + C023502W + C023809W
 Top options: Teak 023204 | Lavastone 023205
 Casual back cushions: 5x C02300W

Total price Teak top: Cat. D € 18.195 E € 19.870 F € 21.280
 Total price Teak top without casual back: Cat. D € 16.445 E € 17.720 F € 18.880
 Total price Lavastone top: Cat. D € 20.260 E € 21.935 F € 23.345
 Cover: D2334 € 1.185

322 / 126.75"

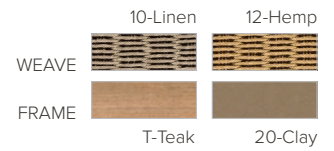

Aluminium, high pressure injected
Aluminium, moulé sous pression
Spuitgegoten aluminium

Plantation teak from Java
Teck de plantation de Java
Plantageteak uit Java

Trizo Rope
Trizo Rope
Trizo Rope

Armchair
Fauteuil repas
Armstoel

€ 1.180 Clay



02718-20-12



02718-T-10



02718-T-12



€ 1.595 Teak

D2718
Cover
Housse
Hoes
€ 215

C02718BW
Back cushion
Coussin dossier
Rugkussen
D € 210
E € 245
F € 290

C02718SW
Seat cushion
Coussin d'assise
Zitkussen
D € 295
E € 340
F € 400



Lounge chair
Fauteuil lounge
Lage zetel

€ 1.780 Clay



02712-20-12



02712-T-10



02712-T-12



€ 2.380 Teak

D2712
Cover
Housse
Hoes
€ 230

C02712BW
Back cushion
Coussin dossier
Rugkussen
D € 280
E € 330
F € 390

C02712SW
Seat cushion
Coussin d'assise
Zitkussen
D € 405
E € 450
F € 535



Aluminium, high pressure injected
Aluminium, moulé sous pression
Spuitgegoten aluminium

Plantation teak from Java
Teck de plantation de Java
Plantageteak uit Java

Trizo Rope
Trizo Rope
Trizo Rope

Banquette

02708-20-10

02708-20-12

€ 3.895

Clay



02708-T-10

02708-T-12

€ 4.995

Teak



D2708

Cover
Housse
Hoes
€ 385

C02708BSETW

Back cushion Set D € 840
Coussin dossier Set E € 990
Rugkussen Set F € 1.170

C02708SW

Seat cushion D € 760
Coussin d'assise E € 895
Zitkussen F € 1.055



44 / 17.25"



Dining table
Table à manger
Eettafel



T-Teak

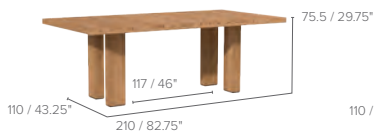

02752-T

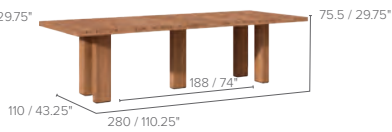

02753-T



02754-T
02755-T
02756-T
02757-T

€ 10.360 210x110cm
€ 12.950 280x110cm
€ 21.205 420x110cm
€ 23.795 490x110cm
€ 26.385 560x110cm
€ 31.565 630x110cm

T-TABLE DINING

TRIBU STUDIO

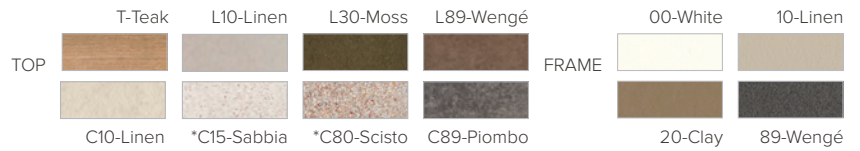

75 / 29.5"  Powdercoated stainless steel
Inox laqué par poudrage
Gepoedercoat inox

Table top: glazed lava stone (L), ceramic (C) or teak (T)
Dessus de table: pierre de lave émaillée (L), céramique (C) ou teck (T)
Tafelblad: geglazuurde lavasteen (L), keramiek (C) of teak (T)

*This colour may possibly show veins
*Des veines peuvent éventuellement figurer sur cette couleur
*Deze kleur kan mogelijk anders vertonen

 Dining table
Table à manger
Eettafel

75 / 29.5"



€ 1.790 Ø 80cm
€ 2.730 Ø 90cm
€ 3.560 Ø 125cm

D2166-00-T
D2160-00-T
D2162-00-T

D2166-10-T
D2160-10-T
D2162-10-T

D2166-20-T
D2160-20-T
D2162-20-T

D2166-89-T
D2160-89-T
D2162-89-T

€ 2.465 Ø 80cm
€ 3.130 Ø 90cm
€ 4.850 Ø 125cm

D2166-00-Cx
D2160-00-Cx
D2162-00-Cx

D2166-10-Cx
D2160-10-Cx
D2162-10-Cx

D2166-20-Cx
D2160-20-Cx
D2162-20-Cx

D2166-89-Cx
D2160-89-Cx
D2162-89-Cx

€ 3.830 Ø 80cm
€ 4.850 Ø 90cm
€ 7.535 Ø 125cm

D2166-00-Lx
D2160-00-Lx
D2162-00-Lx

D2166-10-Lx
D2160-10-Lx
D2162-10-Lx

D2166-20-Lx
D2160-20-Lx
D2162-20-Lx

D2166-89-Lx
D2160-89-Lx
D2162-89-Lx

 Dining table
Table à manger
Eettafel

76.2 / 30"



€ 3.030 90x90cm
€ 3.255 90x90cm
€ 4.980 90x90cm

D2170-00-T
D2170-00-Cx
D2170-00-Lx

D2170-10-T
D2170-10-Cx
D2170-10-Lx

D2170-20-T
D2170-20-Cx
D2170-20-Lx

D2170-89-T
D2170-89-Cx
D2170-89-Lx

 Dining table
Table à manger
Eettafel

75 / 29.5"



€ 3.495 Elipse - 136 x 80cm
€ 3.595 Elipse - 136 x 80cm
€ 5.950 Elipse - 136 x 80cm

D2183-00-T
D2183-00-Cx
D2183-00-Lx

D2183-10-T
D2183-10-Cx
D2183-10-Lx

D2183-20-T
D2183-20-Cx
D2183-20-Lx

D2183-89-T
D2183-89-Cx
D2183-89-Lx

 *Dining table
*Table à manger
*Eettafel

75.2 / 29.5"



€ 6.855 240x98cm
€ 7.685 298x98cm

D2175-00-T
D2176-00-T

D2175-10-T
D2176-10-T

D2175-20-T
D2176-20-T

D2175-89-T
D2176-89-T

€ 6.990 240x98cm
€ 7.950 298x98cm

D2175-00-Cx
D2176-00-Cx

D2175-10-Cx
D2176-10-Cx

D2175-20-Cx
D2176-20-Cx

D2175-89-Cx
D2176-89-Cx

* No lavastone top

Note: the height and clearance under the table may differ according to the type of table top. Please consult the product sheet on our website.

Remarque: la hauteur et le dégagement sous la table peuvent différer selon le type de dessus de table. Pour plus de détails, consultez la fiche produit sur notre site internet.

Opmerking: afhankelijk van het type tafelblad kunnen de hoogte en de vrije ruimte onder de tafel verschillen. Details vindt u op de productfiche op onze website.

T-TABLE LOW DINING

TRIBU STUDIO

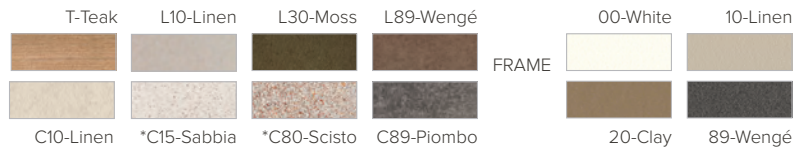

85

67 / 26.5" Powdercoated stainless steel
Inox laqué par poudrage
Gepoedercoat inox

Table top: glazed lava stone (L), ceramic (C) or teak (T)
Dessus de table: pierre de lave émaillée (L), céramique (C) ou teak (T)
Tafelblad: geglazuurde lavasteen (L), keramiek (C) of teak (T)

*This colour may possibly show veins.
*Des veines peuvent éventuellement figurer sur cette couleur
*Deze kleur kan mogelijk anders vertonen.

Low dining table
Table à manger basse
Lage eettafel

68 / 26.75"



€ 1.790 Ø 80cm
€ 2.730 Ø 90cm
€ 3.560 Ø 125cm

D2167-00-T
D2161-00-T
D2163-00-T

D2167-10-T
D2161-10-T
D2163-10-T

D2167-20-T
D2161-20-T
D2163-20-T

D2167-89-T
D2161-89-T
D2163-89-T

€ 2.465 Ø 80cm
€ 3.130 Ø 90cm
€ 4.850 Ø 125cm

D2167-00-Cx
D2161-00-Cx
D2163-00-Cx

D2167-10-Cx
D2161-10-Cx
D2163-10-Cx

D2167-20-Cx
D2161-20-Cx
D2163-20-Cx

D2167-89-Cx
D2161-89-Cx
D2163-89-Cx

€ 3.830 Ø 80cm
€ 4.850 Ø 90cm
€ 7.535 Ø 125cm

D2167-00-Lx
D2161-00-Lx
D2163-00-Lx

D2167-10-Lx
D2161-10-Lx
D2163-10-Lx

D2167-20-Lx
D2161-20-Lx
D2163-20-Lx

D2167-89-Lx
D2161-89-Lx
D2163-89-Lx

Low dining table
Table à manger basse
Lage eettafel

68.2 / 26.75"



€ 3.030 90x90cm
€ 3.255 90x90cm
€ 4.980 90x90cm

D2172-00-T
D2172-00-Cx
D2172-00-Lx

D2172-10-T
D2172-10-Cx
D2172-10-Lx

D2172-20-T
D2172-20-Cx
D2172-20-Lx

D2172-89-T
D2172-89-Cx
D2172-89-Lx

Low Dining table
Table à manger basse
Lage eettafel

68 / 26.75"



€ 3.495 Elipse - 136 x 80cm
€ 3.595 Elipse - 136 x 80cm
€ 5.950 Elipse - 136 x 80cm

D2184-00-T
D2184-00-Cx
D2184-00-Lx

D2184-10-T
D2184-10-Cx
D2184-10-Lx

D2184-20-T
D2184-20-Cx
D2184-20-Lx

D2184-89-T
D2184-89-Cx
D2184-89-Lx

*Low dining table
*Table à manger basse
*Lage eettafel

67.2 / 26.5"



€ 6.855 240x98cm
€ 7.685 298x98cm

D2177-00-T
D2178-00-T

D2177-10-T
D2178-10-T

D2177-20-T
D2178-20-T

D2177-89-T
D2178-89-T

€ 6.990 240x98cm
€ 7.950 298x98cm

D2177-00-Cx
D2178-00-Cx

D2177-10-Cx
D2178-10-Cx

D2177-20-Cx
D2178-20-Cx

D2177-89-Cx
D2178-89-Cx

* No lavastone top

Note: the height and clearance under the table may differ according to the type of table top. Please consult the product sheet on our website.

Remarque: la hauteur et le dégagement sous la table peuvent différer selon le type de dessus de table. Pour plus de détails, consultez la fiche produit sur notre site internet.

Opmerking: afhankelijk van het type tafelblad kunnen de hoogte en de vrije ruimte onder de tafel verschillen. Details vindt u op de productfiche op onze website.

Covers for tables see p.124-127
Des housses pour les tables voir p.124-127
Hoezen voor tafels zie p.124-127

T-TABLE LOW DINING

TRIBU STUDIO

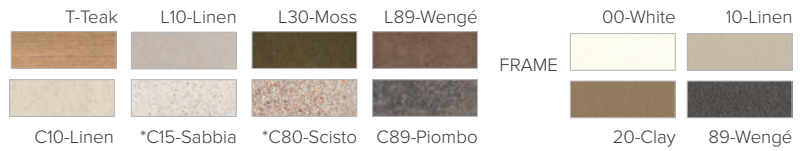

Powdercoated stainless steel
Inox laqué par poudrage
Gepoedercoat inox

Table top: glazed lava stone (L), ceramic (C) or teak (T)
Dessus de table: pierre de lave émaillée (L), céramique (C) ou teak (T)
Tafelblad: geglazuurde lavasteen (L), keramiek (C) of teak (T)

*This colour may possibly show veins.
*Des veines peuvent éventuellement figurer sur cette couleur
*Deze kleur kan mogelijk anders vertonen.



Low dining table
Table à manger basse
Lage eettafel

64 / 25.25"



€ 1.790 Ø 80cm
€ 2.730 Ø 90cm
€ 3.560 Ø 125cm

D2190-00-T
D2191-00-T
D2192-00-T

D2190-10-T
D2191-10-T
D2192-10-T

D2190-20-T
D2191-20-T
D2192-20-T

D2190-89-T
D2191-89-T
D2192-89-T

€ 2.465 Ø 80cm
€ 3.130 Ø 90cm
€ 4.850 Ø 125cm

D2190-00-Cx
D2191-00-Cx
D2192-00-Cx

D2190-10-Cx
D2191-10-Cx
D2192-10-Cx

D2190-20-Cx
D2191-20-Cx
D2192-20-Cx

D2190-89-Cx
D2191-89-Cx
D2192-89-Cx

€ 3.830 Ø 80cm
€ 4.850 Ø 90cm
€ 7.535 Ø 125cm

D2190-00-Lx
D2191-00-Lx
D2192-00-Lx

D2190-10-Lx
D2191-10-Lx
D2192-10-Lx

D2190-20-Lx
D2191-20-Lx
D2192-20-Lx

D2190-89-Lx
D2191-89-Lx
D2192-89-Lx



Low dining table
Table à manger basse
Lage eettafel

64 / 25.25"



€ 3.030 90x90cm
€ 3.255 90x90cm
€ 4.980 90x90cm

D2193-00-T
D2193-00-Cx
D2193-00-Lx

D2193-10-T
D2193-10-Cx
D2193-10-Lx

D2193-20-T
D2193-20-Cx
D2193-20-Lx

D2193-89-T
D2193-89-Cx
D2193-89-Lx



Low Dining table
Table à manger basse
Lage eettafel

64 / 25.25"



€ 3.495 Elipse - 136 x 80cm
€ 3.595 Elipse - 136 x 80cm
€ 5.950 Elipse - 136 x 80cm

D2194-00-T
D2194-00-Cx
D2194-00-Lx

D2194-10-T
D2194-10-Cx
D2194-10-Lx

D2194-20-T
D2194-20-Cx
D2194-20-Lx

D2194-89-T
D2194-89-Cx
D2194-89-Lx



*Low dining table
*Table à manger basse
*Lage eettafel

64 / 25.25"



€ 6.855 240x98cm
€ 7.685 298x98cm

D2195-00-T
D2196-00-T

D2195-10-T
D2196-10-T

D2195-20-T
D2196-20-T

D2195-89-T
D2196-89-T

€ 6.990 240x98cm
€ 7.950 298x98cm

D2195-00-Cx
D2196-00-Cx

D2195-10-Cx
D2196-10-Cx

D2195-20-Cx
D2196-20-Cx

D2195-89-Cx
D2196-89-Cx

* No lavastone top

Note: the height and clearance under the table may differ according to the type of table top. Please consult the product sheet on our website.

Remarque: la hauteur et le dégagement sous la table peuvent différer selon le type de dessus de table. Pour plus de détails, consultez la fiche produit sur notre site internet.

Opmerking: afhankelijk van het type tafelblad kunnen de hoogte en de vrije ruimte onder de tafel verschillen. Details vindt u op de productfiche op onze website.

T-TABLE COFFEE

TRIBU STUDIO

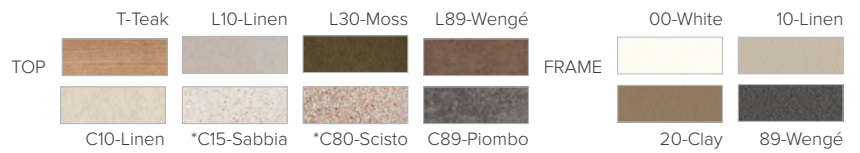

87

35 / 13,75  Powdercoated stainless steel
Inox laqué par poudrage
Gepoedercoat inox

Table top: glazed lava stone (L), ceramic (C) or teak (T)
Dessus de table: pierre de lave émaillée (L), céramique (C) ou teck (T)
Tafelblad: geglazuurde lavasteen (L), keramiek (C) of teak (T)

*This colour may possibly show veins.
*Des veines peuvent éventuellement figurer sur cette couleur

*Deze kleur kan mogelijk anders vertonen.

 Coffee table
Table de salon
Koffietafel

35 / 13,75



€ 1.790 Ø 80cm
€ 2.730 Ø 90cm
€ 3.560 Ø 125cm

D2168-00-T
D2164-00-T
D2165-00-T

D2168-10-T
D2164-10-T
D2165-10-T

D2168-20-T
D2164-20-T
D2165-20-T

D2168-89-T
D2164-89-T
D2165-89-T

€ 2.465 Ø 80cm
€ 3.130 Ø 90cm
€ 4.850 Ø 125cm

D2168-00-Cx
D2164-00-Cx
D2165-00-Cx

D2168-10-Cx
D2164-10-Cx
D2165-10-Cx

D2168-20-Cx
D2164-20-Cx
D2165-20-Cx

D2168-89-Cx
D2164-89-Cx
D2165-89-Cx

€ 3.830 Ø 80cm
€ 4.850 Ø 90cm
€ 7.250 Ø 125cm

D2168-00-Lx
D2164-00-Lx
D2165-00-Lx

D2168-10-Lx
D2164-10-Lx
D2165-10-Lx

D2168-20-Lx
D2164-20-Lx
D2165-20-Lx

D2168-89-Lx
D2164-89-Lx
D2165-89-Lx

 Coffee table
Table de salon
Koffietafel

35 / 13,75



€ 3.030 90x90cm
€ 3.255 90x90cm
€ 4.980 90x90cm

D2174-00-T
D2174-00-Cx
D2174-00-Lx

D2174-10-T
D2174-10-Cx
D2174-10-Lx

D2174-20-T
D2174-20-Cx
D2174-20-Lx

D2174-89-T
D2174-89-Cx
D2174-89-Lx

 Coffee table
Table de salon
Koffietafel

35 / 13,75*



€ 3.495 Elipse - 136 x 80cm
€ 3.595 Elipse - 136 x 80cm
€ 5.950 Elipse - 136 x 80cm

D2185-00-T
D2185-00-Cx
D2185-00-Lx

D2185-10-T
D2185-10-Cx
D2185-10-Lx

D2185-20-T
D2185-20-Cx
D2185-20-Lx

D2185-89-T
D2185-89-Cx
D2185-89-Lx

 *Coffee table
*Table de salon
*Koffietafel

35 / 13,75



€ 6.855 240x98cm
€ 7.685 298x98cm

D2179-00-T
D2180-00-T

D2179-10-T
D2180-10-T

D2179-20-T
D2180-20-T

D2179-89-T
D2180-89-T

€ 6.990 240x98cm
€ 7.950 298x98cm

D2179-00-Cx
D2180-00-Cx

D2179-10-Cx
D2180-10-Cx

D2179-20-Cx
D2180-20-Cx

D2179-89-Cx
D2180-89-Cx

* No lavastone top

Note: the height and clearance under the table may differ according to the type of table top. Please consult the product sheet on our website.

Remarque: la hauteur et le dégagement sous la table peuvent différer selon le type de dessus de table. Pour plus de détails, consultez la fiche produit sur notre site internet.

Opmerking: afhankelijk van het type tafelblad kunnen de hoogte en de vrije ruimte onder de tafel verschillen. Details vindt u op de productfiche op onze website.

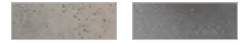

Lightened concrete
Béton allégé
Verlicht beton

This material is sensitive to stains
Ce matériau est sensible aux taches
Dit materiaal is vlekgevoelig

Dining Table
Table à manger
Eettafel



€ 6.450
€ 7.750

Ø 160cm
Ø 180cm

01666-10
01668-10

01666-89
01668-89

Dining Table
Table à manger
Eettafel



€ 8.350

Oval

01670-10

01670-89

Weight filling bag included
Sac de remplissage inclus
Verzwarende zak voor stabiliteit inclusief

Coffee Table
Table de salon
Koffietafel

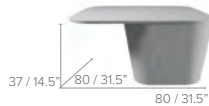

€ 2.495

01682-10

01682-89

Powdercoated stainless steel
Inox laqué par poudrage
Gepoedercoat inox

Braiding: foam in a knitted sheath of Tricord® (polyofin) and textile
Tressage: mousse dans une housse tricotée de Tricord® (polyoléfine) et textile
Vlechtwerk: schuim in een gebreide hoes van Tricord® (polyolefine) en textiel

Seat support: Batyline
Support d'assise: Batyline
Zitvlak: Batyline

Armchair
Fauteuil repas
Armstoel

€ 1.460

05318-10



05318-89



D5318
Cover
Housse
Hoes
€ 180

C05318BW
Back cushion
Coussin dossier
Rugkussen
D € 140
E € 160
F € 210

C05318SW
Seat cushion
Coussin d'assise
Zitkussen
D € 175
E € 230
F € 320



Counter height chair
Fauteuil à hauteur de comptoir
Stoel aanrechthoogte

€ 1.690

05315-10



05315-89



D5315
Cover
Housse
Hoes
€ 215

C05318BW
Back cushion
Coussin dossier
Rugkussen
D € 140
E € 160
F € 210

C05315SW
Seat cushion
Coussin d'assise
Zitkussen
D € 180
E € 235
F € 330



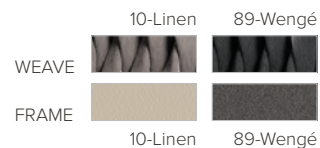

Powdercoated stainless steel
Inox laqué par poudrage
Gepoedercoat inox

Braiding: foam in a knitted sheath of Tricord® (polyofin) and textilene
Tressage: mousse dans une housse tricotée de Tricord® (polyoléfine) et textilène
Vlechtwerk: schuim in een gebreide hoos van Tricord® (polyolefine) en textileen

Seat support: Batyline
Support d'assise: Batyline
Zitvlak: Batyline

Low dining chair
Fauteuil low dining
Stoel low dining

05317-10

05317-89

€ 2.490

**D5317**

Cover
Housse
Hoes
€ 240

C05317BW

Back cushion D € 270
Coussin dossier E € 310
Rugkussen F € 360

C05317SW

Seat cushion D € 435
Coussin d'assise E € 480
Zitkussen F € 555



Lounge chair
Fauteuil Lounge
Lage zetel

05302-10

05302-89

€ 3.540

**D5302**

Cover
Housse
Hoes
€ 230

C05302BW

Back cushion D € 295
Coussin dossier E € 335
Rugkussen F € 385

C05302SW

Seat cushion D € 690
Coussin d'assise E € 725
Zitkussen F € 795

**C0013W**

Option lumbar cushion D € 100
Option coussin lombaire E € 120
Optie lendenkussen F € 140



Powdercoated stainless steel
Inox laqué par poudrage
Gepoedercoat inox

Braiding: foam in a knitted sleeve of Tricord® (polyofin) and textile
Tressage: mousse dans une housse tricotée de Tricord® (polyoléfine) et textile
Vlechtwerk: schuim in een gebreide hoes van Tricord® (polyolefine) en textiel

Seat support: Batyline
Support d'assise: Batyline
Zitvlak: Batyline

2-Seater sofa
Canapé 2 places
Sofa 2-zit

05308-10

05308-89

€ 5.095

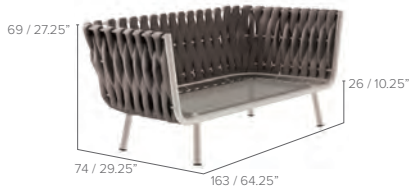

D5308

Cover
Housse
Hoes
€ 305

C05308BW

Back cushion
Coussin dossier
Rugkussen
(order 2x!)

D € 295
E € 335
F € 385

C05308SW

Seat cushion
Coussin d'assise
Zitkussen

D € 1.090
E € 1.165
F € 1.250



C0013W

Option lumbar cushion
Option coussin lombaire
Optie lendenkussen

D € 100
E € 120
F € 140



3-Seater sofa
Canapé 3 places
Sofa 3-zit

05309-10

05309-89

€ 6.845



D5309

Cover
Housse
Hoes
€ 375

C05309BW

Back cushion
Coussin dossier
Rugkussen
(order 3x!)

D € 295
E € 335
F € 385

C05309SW

Seat cushion
Coussin d'assise
Zitkussen

D € 1.475
E € 1.590
F € 1.705



C0013W

Option lumbar cushion
Option coussin lombaire
Optie lendenkussen

D € 100
E € 120
F € 140



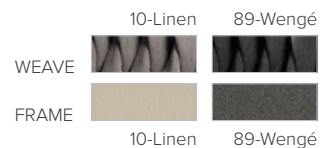

Powdercoated stainless steel
Inox laqué par poudrage
Gepoedercoat inox

Braiding: foam in a knitted sleeve of Tricord® (polyofin) and textilene
Tressage: mousse dans une housse tricotée de Tricord® (polyoléfine) et textilène
Vlechtwerk: schuim in een gebreide hoos van Tricord® (polyolefine) en textileen

Seat support: Batyline
Support d'assise: Batyline
Zitvlak: Batyline

Adjustable lounger
Chaise longue réglable
Ligbed, verstelbaar

€ 4.840

05340-10



05340-89



D5340

Cover
Housse
Hoes
€ 325

C05340W

Cushion
Coussin
Kussen
D € 885
E € 940
F € 1.010



Daybed
Daybed
Daybed

€ 10.590

05349-10

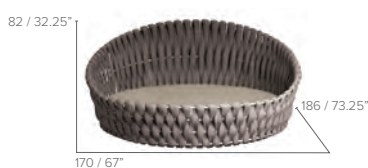

05349-89



D5349

Cover
Housse
Hoes
€ 385

C05349BW

Back cushion
Coussin dossier
Rugkussen
70x60cm, order 3x!
D € 260
E € 305
F € 345

C05349SW

Seat cushion
Coussin d'assise
Zitkussen
D € 1.840
E € 2.030
F € 2.195



For optimal comfort, we recommend completing the Daybed with 3 backs and several deco cushions (p. 115)

Pour une ambiance confortable, nous recommandons de compléter le Daybed avec 3 coussins dossier et plusieurs coussins déco (page 115)

Voor een gezellig gevoel, raden wij aan het Daybed te vullen met 3 rugkussens en verschillende decokussens (pag. 115)

Powdercoated stainless steel
Inox laqué par poudrage
Gepoedercoat inox

Table top: ceramic
Dessus de table: céramique
Tafelblad: keramiek

*This colour may possibly show veins
*Des veines peuvent éventuellement figurer sur cette couleur
*Deze kleur kan mogelijk anders vertonen

Dining table
Table à manger
Eettafel



€ 5.780 240cm
€ 7.175 298cm

05355-10-xx
05354-10-xx

05355-89-xx
05354-89-xx

Low Dining table
Table low dining
Tafel low dining



€ 5.660 240cm
€ 7.055 298cm

05335-10-xx
05334-10-xx

05335-89-xx
05334-89-xx

Side table
Table d'appoint
Bijzettafel

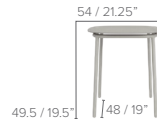

€ 1.480

05381-10-xx

05381-89-xx

Coffee Table
Table de salon
Koffietafel

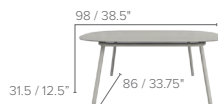

€ 2.485

05386-10-xx

05386-89-xx

Plantation teak from Java
Teck de plantation de Java
Plantageteak uit Java

3 Armchair
Fauteuil repas
Armstoel

€ 1.225



D7518
Cover
Housse
Hoes
€ 200

C07518W
Seat & back cushion D € 375
Coussin d'assise et de dossier E € 485
Zit- en rugkussen F € 615

C07518SW
Seat cushion D € 155
Coussin d'assise E € 215
Zitkussen F € 285



3 Lounge chair
Fauteuil Lounge
Lage zetel

€ 1.475



D7512
Cover
Housse
Hoes
€ 220

C07512BW
Back cushion D € 320
Coussin dossier E € 350
Rugkussen F € 370

C07512SW
Seat cushion D € 280
Coussin d'assise E € 355
Zitkussen F € 450



3 Adjustable lounger
Chaise longue réglable
Ligbed, verstelbaar

€ 2.240



D7540
Cover
Housse
Hoes
€ 300

***C07540W**
Cushion D € 605
Coussin E € 865
Kussen F € 1.165
*Head support not included

C0005W
Head support lounger for Ukiyo D € 200
Repose tête chaise longue pour Ukiyo E € 240
Hoofdsteun ligbed voor Ukiyo F € 280



Plantation teak from Java
Teck de plantation de Java
Plantageteak uit Java

Table top: ceramic
Dessus de table: céramique
Tafelblad: keramiek

*This colour may possibly show veins.
*Des veines peuvent éventuellement figurer sur cette couleur
*Deze kleur kan mogelijk anders vertonen.

Dining table
Table à manger
Eettafel



€ 6.995

07553-xx

Coffee table
Table de salon
Koffietafel



€ 2.495

07586-xx

Low table
Table de salon
Lage tafel



€ 2.995

07588-xx

Plantation teak from Java
Teck de plantation de Java
Plantageteak uit Java

Lounger, adjustable
Chaise longue, réglable
Ligbed, verstelbaar

01740
01740W***

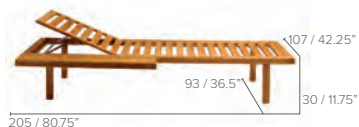

€ 2.605
€ 345

***Set of wheels ***Set de roues ***Set wielen

D6130
Cover
Housse
Hoes
€ 305

C01740W
Cushion
Coussin
Kussen

D € 1.195
E € 1.440
F € 1.685

C01741W

Project cushion*
Coussin de projet*
Projectkussen*

D € 835
E € 1.040
F € 1.205



* 2 compartment cushion without headrest
* Coussin deux compartiments sans repose-tête
* 2-delig kussen zonder hoofdsteun

Lounger, adjustable, wheels
Chaise longue, réglable, roues
Ligbed, verstelbaar, wielen

01741

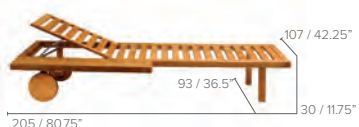

€ 2.890

D6130
Cover
Housse
Hoes
€ 305

C01740W
Cushion
Coussin
Kussen

D € 1.195
E € 1.440
F € 1.685

C01741W

Project cushion*
Coussin de projet*
Projectkussen*

D € 835
E € 1.040
F € 1.205



* 2 compartment cushion without headrest
* Coussin deux compartiments sans repose-tête
* 2-delig kussen zonder hoofdsteun

Dining table
Table à manger
Eettafel



€ 2.815 99x99cm
€ 8.395 300x99cm
€ 10.725 400x99cm
€ 13.905 500x99cm**
€ 16.240 600x99cm**
€ 18.565 700x99cm**

01773

01753
01754
01755
01756
01757

** From a length of 5 m or more, a third set of legs is added

** A partir d'une longueur de 5 m ou plus, un troisième set de pattes est ajouté

** Vanaf een lengte van 5 m of meer wordt een derde set poten toegevoegd

Covers for tables see p.124-127
Des housses pour les tables voir p.124-127
Hoezen voor tafels zie p.124-127

VIS À VIS SOFA

PIERGIORGIO CAZZANIGA

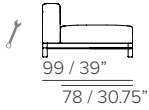

Plantation teak from Java
Teck de plantation de Java
Plantageteak uit Java

Brackets for cushions in stainless steel
Arcs pour les coussins en acier inoxydable
Beugels voor kussens in inox

Casual back cushions **not included***
Coussins dossier Casual **non inclus***
Casual rugkussens **niet inbegrepen***

Pouf module

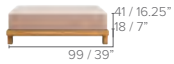

Frame
01792
€ 1.200

Cushion
C01792W
D € 1.295
E € 1.390
F € 1.600

Cover D1792 € 195

Extension module single



Frame
01700
€ 1.200

Cushion
C01700W
D € 1.890
E € 2.030
F € 2.335

Cover D1700 € 240

Corner module right arm

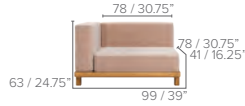

Frame
01701R
€ 1.200

Cushion
C01701W
D € 2.535
E € 2.725
F € 3.130

Cover D1731R € 285

Corner module left arm



Frame
01701L
€ 1.200

Cushion
C01701W
D € 2.535
E € 2.725
F € 3.130

Cover D1731L € 285

Center module



Frame
01708
€ 2.090

Cushion
C01708W
D € 2.590
E € 2.780
F € 3.200

Cover D1732 € 330

Extension pouf left



Frame
01706L
€ 2.090

Cushion
C01706W
D € 3.185
E € 3.420
F € 3.935

Cover D1730L € 365

Extension pouf right



Frame
01706R
€ 2.090

Cushion
C01706W
D € 3.185
E € 3.420
F € 3.935

Cover D1730R € 365

Extension module double



Frame
01728
€ 2.090

Cushion
C01728W
D € 3.780
E € 4.060
F € 4.670

Cover D1728 € 365

Right arm module



Frame
01738R
€ 2.090

Cushion
C01738W
D € 4.430
E € 4.755
F € 5.465

Cover D1738R € 385

Left arm module



Frame
01738L
€ 2.090

Cushion
C01738W
D € 4.430
E € 4.755
F € 5.465

Cover D1738L € 385

2-Seater sofa



Frame
01709
€ 2.090

Cushion
C01709W
D € 5.070
E € 5.450
F € 6.260

Cover D1733 € 385

Meridienne right short arm



Frame
01704S
€ 2.090

Cushion
C01704SW
D € 3.830
E € 4.115
F € 4.730

Cover D1704S € 385

Meridienne left short arm



Frame
01703S
€ 2.090

Cushion
C01703SW
D € 3.830
E € 4.115
F € 4.730

Cover D1703S € 385

Meridienne right long arm



Frame
01704
€ 2.090

Cushion
C01704W
D € 3.830
E € 4.115
F € 4.730

Cover D1720R € 385

Meridienne left long arm



Frame
01703
€ 2.090

Cushion
C01703W
D € 3.830
E € 4.115
F € 4.730

Cover D1720L € 385

Daybed module



Frame
01742
€ 2.090

Cushion
C01742W
D € 3.185
E € 3.420
F € 3.935

Cover D1742 € 385



Plantation teak from Java
Teck de plantation de Java
Plantageteak uit Java

Casual back cushion
Coussin dossier Casual
Casual rugkussen
63x45x15cm

C0012W



To order separately!
A commander séparément!
Apart te bestellen!

€ 345 Cat D
€ 430 Cat E
€ 480 Cat F

High backrest cushion*
Coussin dossier élevé*
Hoog rugkussen*
76x60x15cm

C0012BHW



To order separately!
A commander séparément!
Apart te bestellen!

*Support bracket in stainless steel with cover in fabric included
*Arc de support en acier inoxydable avec housse en tissu inclus
*Steunbeugel in inox met stoffen hoese inbegrepen

€ 695 Cat D
€ 840 Cat E
€ 965 Cat F

Coffee table
Table de salon
Koffietafel



Cover
Housse
Hoes

€ 2.115 99x99cm
€ 2.700 121x99cm
€ 3.300 121x121cm
€ 1.945 159x44cm

01781
01784
01786

01732

D1781 € 140
D1784 € 165
D1786 € 220
D1735 € 245

Bench
Banc
Bank

01734



€ 1.995 H44cm

C01734W

Cushion D € 545
Coussin E € 675
Kussen F € 825

D1734

Cover
Housse
Hoes
€ 245

Options borders H 18cm
Options modules bord H 18cm
Optie boorden H 18cm

01700B
€ 1.950

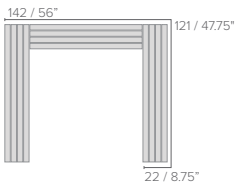

01701B
€ 1.255

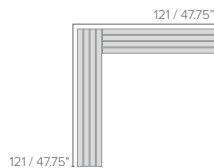

01704B
€ 1.390

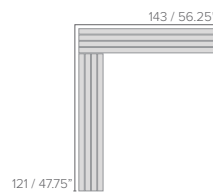

01706B
€ 1.120



01709B
€ 2.510

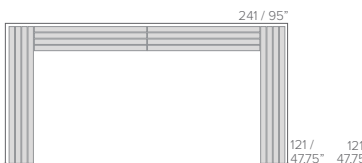

01738B
€ 1.815

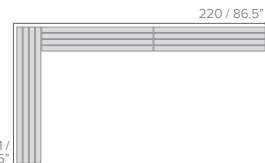

01796B
€ 560

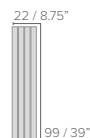

01797B
€ 695

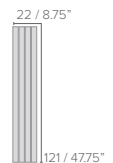

VIS À VIS SOFA SETS

PIERGIORGIO CAZZANIGA

Custom covers = €165 per single seat and €330 for meridienne and daybed modules
 Housses sur mesure = €165 par siège simple et €330 pour les modules méridienne et daybed
 Covers op maat = €165 per enkele zitplaats en €330 voor meridienne en daybed modules

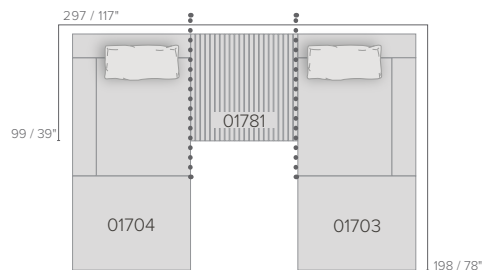

SET 1b
 frame: 01704 + 01703 + 01781
 cushions: C01704W + C01703W
 back cushions: 2x C0012W

total price: Cat. D **€ 14.645 E € 15.385 F € 16.715**
 price without table: Cat. D **€ 12.530 E € 13.270 F € 14.600**
 cover: D1720L + D1720R **2x € 385 = 770 €**

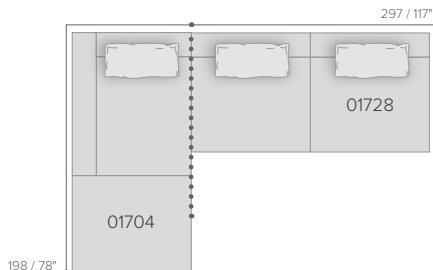

SET 2a
 frame: 01704 + 01728
 cushions: C01704W + C01728W
 back cushions: 3x C0012W

total price: Cat. D **€ 12.825 E € 13.645 F € 15.020**
 cover: D1905 **€ 655**

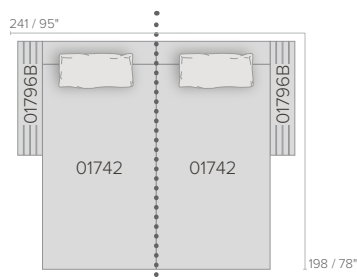

SET 3b
 frame: 2x 01742 + 2x 01796B
 cushions: 2x C01742W
 back cushions: 2x C0012W

total price: Cat. D **€ 12.360 E € 13.000 F € 14.130**
 price without borders: Cat. D **€ 11.240 E € 11.880 F € 13.010**
 cover: D1721 **€ 655**

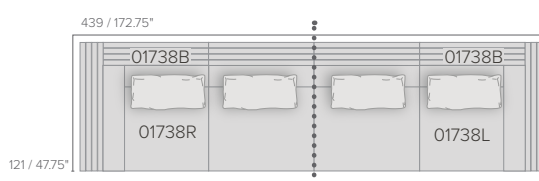

SET 4
 frame: 01738R + 01738L + 2x 01738B
 cushions: 2x C01738W
 back cushions: 4x C0012W

total price: Cat. D **€ 18.050 E € 19.040 F € 20.660**
 price without borders: Cat. D **€ 14.420 E € 15.410 F € 17.030**
 cover: D1704 **€ 655**

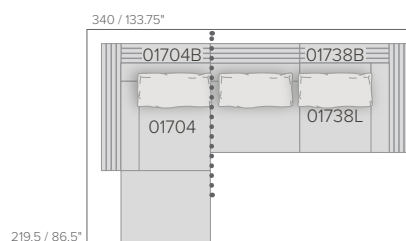

SET 5
 frame: 01704 + 01738L + 01738B + 01704B
 cushions: C01704W + C01738W
 back cushions: 3x C0012W

total price: Cat. D **€ 16.680 E € 17.545 F € 19.020**
 price without borders: Cat. D **€ 13.475 E € 14.340 F € 15.815**
 cover: D1705 **€ 655**

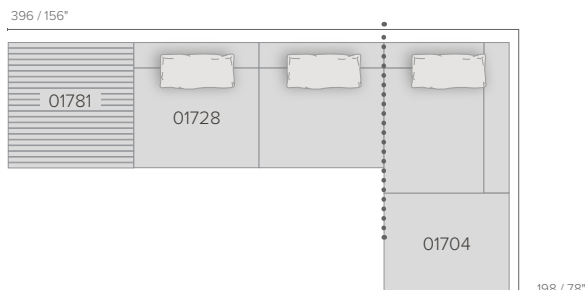

SET 6c
 frame: 01781 + 01728 + 01704
 cushions: C01728W + C01704W
 back cushions: 3x C0012W

total price: Cat. D **€ 14.940 E € 15.760 F € 17.135**
 price without table: Cat. D **€ 12.825 E € 13.645 F € 15.020**
 cover: D1906 **€ 655**



Covers cover only the cushions, not the borders or tables. In case you order a high back cushion, please indicate the position on your set.

Les housses couvrent uniquement les coussins, pas les bords ou les tables. Si vous commandez un coussin de dossier élevé, veuillez indiquer sa position sur votre set.

De hoezen bedekken enkel de kussens, niet de boorden of tafels. Indien u een high back kussen bestelt, gelieve de positie ervan aan te duiden op uw set.

439.5 / 173"

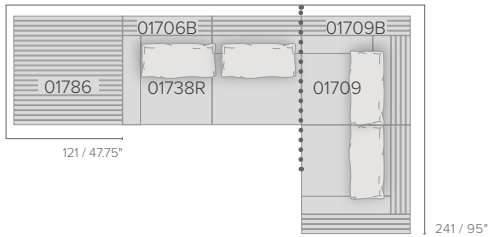
**SET 7**

frame: 01738R + 01709 + 01786 + 01706B + 01709B

cushions: C01738W + C01709W

back cushions: 4x C0012W

total price: Cat. D € 21.990 E € 23.035 F € 24.755

price without borders & table: Cat. D € 15.060 E € 16.105 F € 17.825

cover: D1707 € 655

495 / 195"

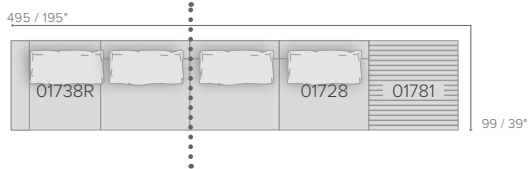
**SET 8**

frame: 01738R + 01728 + 01781

cushions: C01738W + C01728W

back cushions: 4x C0012W

total price: Cat. D € 15.885 E € 16.830 F € 18.350

price without table: Cat. D € 13.770 E € 14.715 F € 16.235

cover: D1716 € 655

417 / 164.25"

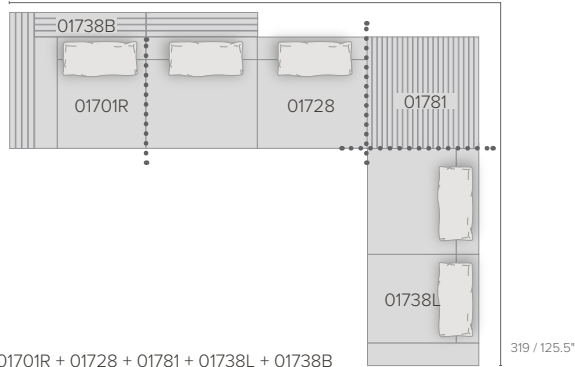
**SET 9a**

frame: 01701R + 01728 + 01781 + 01738L + 01738B

cushions: C01701W + C01728W + C01738W

back cushions: 5x C0012W

total price: Cat. D € 21.780 E € 23.000 F € 24.975

price without borders & table: Cat. D € 17.850 E € 19.070 F € 21.045

cover: D1907 + D1738L € 495 + € 385 = € 880

516 / 203.25"

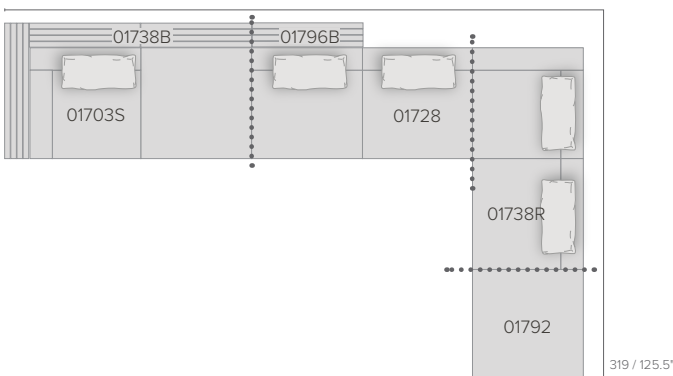
**SET 11a**

frame: 01703S + 01728 + 01738R + 01792 + 01738B + 01796B

cushions: C01703SW + C01728W + C01738W + C01792W

back cushions: 5x C0012W

total price: Cat. D € 24.905 E € 26.315 F € 28.710

price without borders & table: Cat. D € 22.530 E € 23.940 F € 26.335

cover: D1909 € 1.150

396 / 156"

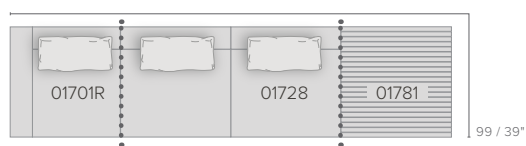
**SET 10a**

frame: 01701R + 01728 + 01781

cushions: C01701W + C01728W

back cushions: 3x C0012W

total price: Cat. D € 12.755 E € 13.480 F € 14.645

price without table: Cat. D € 10.640 E € 11.365 F € 12.530

cover: D1908 € 495

516 / 203.25"

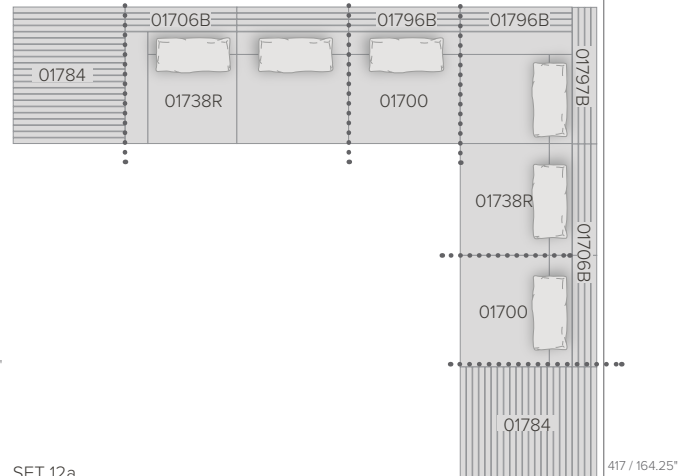
**SET 12a**

frame: 2x 01784 + 2x 01738R + 2x 01700 + 2x 01796B + 2x 01706B + 01797B

cushions: 2x C01738W + 2x C01700W

back cushions: 5x C0012W

total price: Cat. D € 30.745 E € 32.185 F € 34.515

price without borders & table: Cat. D € 21.290 E € 22.730 F € 25.060

cover: D1910 € 985

VIS À VIS SOFA SETS

PIERGIORGIO CAZZANIGA

Covers cover only the cushions, not the borders or tables. In case you order a high back cushion, please indicate the position on your set.

Les housses couvrent uniquement les coussins, pas les bords ou les tables. Si vous commandez un coussin de dossier élevé, veuillez indiquer sa position sur votre set.

De hoezen bedekken enkel de kussens, niet de boorden of tafels. Indien u een high back kussen bestelt, gelieve de positie ervan aan te duiden op uw set.

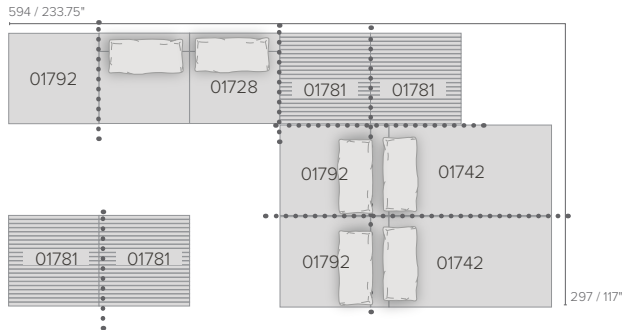

SET 13a

frame: 3x 01792 + 01728 + 2x 01742 + 4x 01781
 cushions: 3x C01792W + C01728W + 2x C01742W
 back cushions: 6x C0012W

total price: Cat. D € 34.435 E € 35.980 F € 38.550
 price without tables: Cat. D € 25.975 E € 27.520 F € 30.090
 cover: D1911 € 1.470

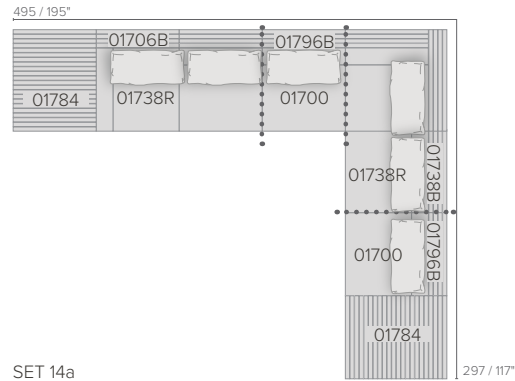

SET 14a

frame: 2x 01784 + 2x 01738R + 2x 01700 + 2x 01796B + 01706B + 01738B
 cushions: 2x C01738W + 2x C01700W
 back cushions: 6x C0012W

total price: Cat. D € 30.745 E € 32.185 F € 34.515
 price without tables: Cat. D € 21.290 E € 22.730 F € 25.060
 cover: D1913 € 980

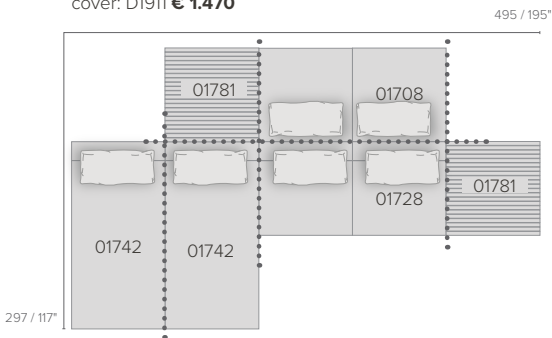

SET 15a

frame: 01708 + 2x 01742 + 01728 + 2x 01781
 cushions: C01708W + C01728W + 2x C01742W
 back cushions: 6x C0012W

total price: Cat. D € 27.400 E € 28.850 F € 31.210
 price without tables: Cat. D € 23.170 E € 24.620 F € 26.980
 cover: D1724 € 1.310

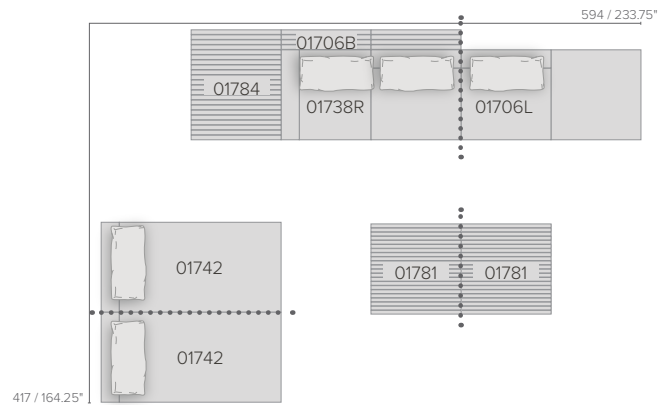

SET 16a

frame: 2x 01742 + 2x 01781 + 01784 + 01738R + 01706L + 01706B
 cushions: 2x C01742W + C01738W + C01706W
 back cushions: 5x C0012W

total price: Cat. D € 32.120 E € 33.575 F € 36.080
 price without tables: Cat. D € 24.070 E € 25.525 F € 28.030
 cover: D1914 + D1721 € 655 + € 655 = € 1.310

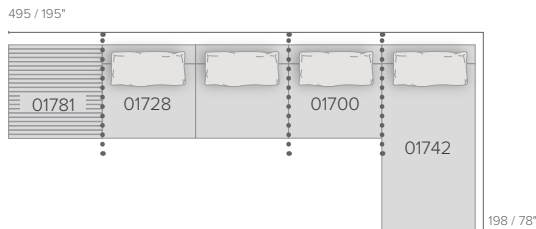

SET 17a

frame: 01781 + 01728 + 01700 + 01742
 cushions: C01728W + C01700W + C01742W
 back cushions: 4x C0012W

total price: Cat. D € 17.730 E € 18.725 F € 20.355
 price without tables: Cat. D € 15.615 E € 16.610 F € 18.240
 cover: D1915 € 820

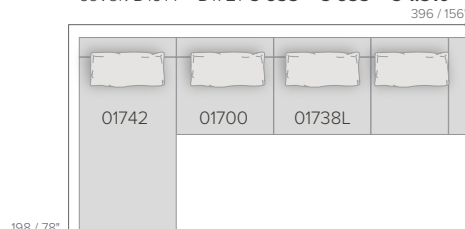

SET 18

frame: 01742 + 01700 + 01738L
 cushions: C01742 + C01700W + C01738W
 back cushions: 4x C0012W

total price: Cat. D € 16.265 E € 17.305 F € 19.035
 cover: D1729 € 820

UMBRELLAS

PARASOL

☉ = solution-dyed / teinté dans la masse / in de massa geverfd

Eucalyptus wood
Bois d'eucalyptus
Eucalyptushout

Base not included
Pied non inclus
Voet niet inbegrepen

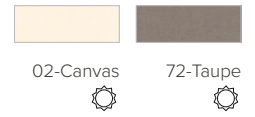

Eclipse (round)
Eclipse (ronde)
Eclipse (rond)



Cover
Housse
Hoes

€ 2.035 dia 350 cm
Mast Ø 63 mm

UW315-02

UW315-72

D6003-X

€ 140

Eclipse (square)
Eclipse (carré)
Eclipse (vierkant)



Cover
Housse
Hoes

€ 2.165 300x300 cm
€ 2.435 350x350 cm
Mast Ø 63 mm

UW322-02
UW323-02

UW322-72
UW323-72

D6003-X
D6004-X

€ 140
€ 160



Granite base
Base en granite
Graniet voet

€ 435

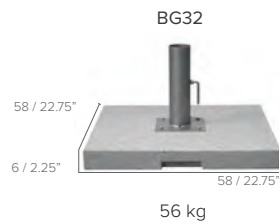

LOW TABLES ALUMINIUM

TABLES BASSES - BIJZETTAFELS

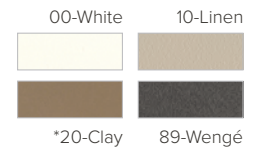

103

Powdercoated aluminium
Aluminium laqué par poudrage
Gepoedercoat aluminium

* Only for Natal Alu X

Drops

D5026-00

40 / 15.75"



D5026-10



D5026-89



€ 500

Dia 40cm

Drops

D5027-00

60 / 23.5"



D5027-10



D5027-89



€ 900

Dia 60cm

Each packaging contains 3 tubes of 30, 40 and 50cm height. One of the 3 can be assembled as table leg, according to your liking.
Chaque emballage contient 3 tubes d'une hauteur de 30, 40 et 50cm. Au choix un des 3 peut être monté comme pied de table.
Elke verpakking bevat 3 tubes met een hoogte van 30, 40 en 50cm. Naar keuze kan één van de 3 gemonteerd worden als tafelpoot.

Natal Alu X high round
Natal Alu X haute ronde
Natal Alu X hoog rond

€ 575

06176-00



06176-10



06176-20



06176-89



Natal Alu X low 40x40cm
Natal Alu X basse 40x40cm
Natal Alu X laag 40x40cm

€ 645

06180-00

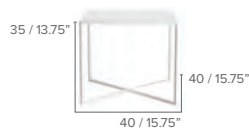

06180-10



06180-20



06180-89



Natal Alu X low 60x60cm
Natal Alu X basse 60x60cm
Natal Alu X laag 60x60cm

€ 1.050

06182-00



06182-10



06182-20



06182-89



Covers for tables see p.124-127
Des housses pour les tables voir p.124-127
Hoezen voor tafels zie p.124-127

LOW TABLES MARE

TABLES BASSES - BIJZETTAFELS

NEW

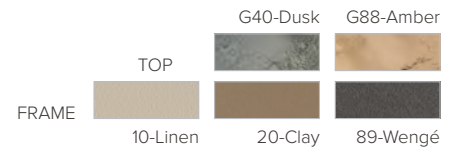

Mare Side Table

04560-10-Gx

32 / 12.5"



26 / 10.25"

04560-20-Gx



04560-89-Gx



€ 750

Dia 32 cm - H40/50cm

Mare Side Table

04580-10-Gx

48 / 19"



39 / 15.25"

04580-20-Gx



04580-89-Gx



€ 1.100

Dia 48 cm - H40/50cm

Each packaging contains 2 tubes of 40 and 50cm height. One of the 2 can be assembled as table leg, according to your liking.
 Chaque emballage contient 2 tubes d'une hauteur de 40 et 50cm. Au choix un des 2 peut être monté comme pied de table.
 Elke verpakking bevat 3 tubes met een hoogte van 40 en 50cm. Naar keuze kan één van de 2 gemonteerd worden als tafelpoot.

LOW TABLES SEREN NEW

TABLES BASSES - BIJZETTAFELS

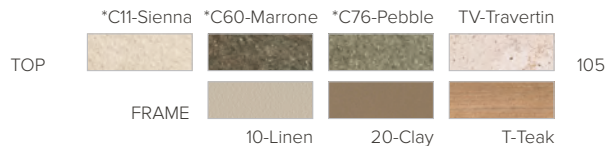

*This colour may possibly show veins
 *Des veines peuvent éventuellement figurer sur cette couleur
 *Deze kleur kan mogelijk anders vertonen

Seren Side Table - 58x58 - H39cm

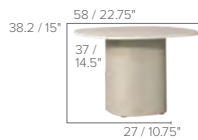

02882-x-Cx



02882-x-TV



02882-T-Cx



02882-T-TV

€ 1.350 Alu - Ceramic
 € 1.880 Alu - Travertin

€ 1.450 Teak - Ceramic
 € 1.980 Teak - Travertin

Seren Side Table - 58x58 - H46cm



02884-x-Cx



02884-x-TV



02884-T-Cx



02884-T-TV

€ 1.390 Alu - Ceramic
 € 1.945 Alu - Travertin

€ 1.490 Teak - Ceramic
 € 2.045 Teak - Travertin

Seren Coffee Table - 150x100 - H32cm

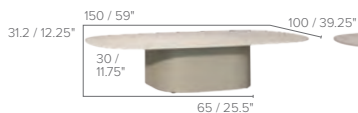

02886-x-Cx



02886-x-TV



02886-T-Cx



02886-T-TV

€ 2.800 Alu - Ceramic
 € 5.165 Alu - Travertin

€ 2.950 Teak - Ceramic
 € 5.315 Teak - Travertin

TABLES BASSES - BIJZETTAFELS

Plantation teak from Java
Teck de plantation de Java
Plantageteak uit Java

 Dunes Side table
Dunes Table d'appoint
Dunes Bijzettafel



€ 2.275

 Dunes Coffee table
Dunes Table de salon
Dunes Koffietafel



€ 2.085

 **NEW** Dunes Side table - small
Dunes Table d'appoint - petit
Dunes Bijzettafel - klein



€ 3.000

 **NEW** Dunes Side table - Large
Dunes Table d'appoint - grand
Dunes Bijzettafel - groot



€ 4.000

 Dunes Low Dining table
Dunes Table low dining
Dunes Tafel low dining

Limited availability



€ 16.900

Roots

€ 1.590



C-table
Table C
C-tafel



€ 900

Pure - H48cm - H19"

02685



44 / 17.25"

44 / 17.25"

NEW € 1.150 Amanu - H50cm - H19.75"

The Dunes and Roots collections are defined by the elegant pattern of the wood grain. Chiseled out of Tribù's plantation-grown teak, every detail, every knot, every crack is proudly on display.

La forme de Dunes and Roots est déterminée par les sinuosités élégantes du grain du bois. Trouvant leur origine dans les plantations de teck de Tribù, chaque détail, chaque nœud, chaque fissure du bois sont superbement mis en valeur.

De Dunes and Roots collecties hebben hun vorm te danken aan de elegante houtnerven. De meubels zijn gemaakt van Tribù's plantage-teak, en dragen elk detail, elke knoop, elke scheur met trots.

LOW TABLES TEAK

TABLES BASSES - BIJZETTAFELS

The teak base is not made of solid teak
La base en teck n'est pas en teck massif
De basis in teak is niet gemaakt uit massief teak

Tairu

D8103-Lx



Lx-Table top: glazed lava stone
Lx-Dessus de table: pierre de lave émaillée
Lx-Tafelblad: geglazuurde lavasteen

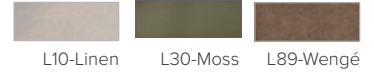

€ 1.240 Lavastone

Hexagon

Coffee Table

Side Table



D5040-Lx



D5041-Lx

€ 1.430 Lavastone

€ 1.340 Lavastone

Otto

Dia 48cm - H32cm

Dia 60cm - H32cm

Dia 90cm - H32cm



04281-Cx
04281-T
04281-TV



04283-Cx
04283-T
04283-TV

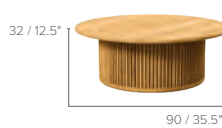

04284-Cx
04284-T
04284-TV

Table top: ceramic, travertine or teak
Dessus de table: céramique, travertin ou teak
Tafelblad: keramiek, travertin of teak

€ 1.495 Ceramic
€ 1.495 Teak
€ 2.100 Travertine

€ 1.695 Ceramic
€ 1.695 Teak
€ 2.600 Travertine

€ 2.145 Ceramic
€ 2.145 Teak
€ 4.600 Travertine

*C15-Sabbia *C80-Scisto
**TV-Travertine T-Teak

Dia 48cm - H45cm

Dia 60cm - H45cm



04280-Cx
04280-T
04280-TV



04282-Cx
04282-T
04282-TV

€ 1.595 Ceramic
€ 1.595 Teak
€ 2.200 Travertine

€ 1.795 Ceramic
€ 1.795 Teak
€ 2.600 Travertine

* This colour may possibly show veins - Des veines peuvent éventuellement figurer sur cette couleur - Deze kleur kan mogelijk anders vertonen

** This material is sensitive to stains - Ce matériau est sensible aux taches - Dit materiaal is vlekgevoelig

Covers for tables see p.124-127
Des housses pour les tables voir p.124-127
Hoezen voor tafels zie p.124-127

ACCESSORIES

ACCESSOIRES

Lanterns
Lanternes
Lantaarns

Lantern low

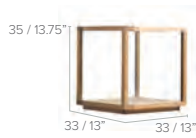

D5015

Lantern high



D5016

Lantern support



D5017

Teak frame



Chemically tempered glass
Verre trempé chimiquement
Chemisch versterkt glas

€ 390
€ 450
€ 460

Luna
incl adapter



D09010-89

Powdercoated Aluminium
89-Wengé



Handblown glass
Verre soufflé à la bouche
Handgeblazen glas

€ 995

Gobi

Small



D3020-x

Large



D3010-x

Recycled Acrylic
Acrylique recyclé
Gerecycleerd Acryl



10-Linen

30-Moss

€ 895
€ 1.250

Gobi baskets dry very slowly, so we advise you not to leave this product out in the rain. We do not have any covers in our range.
Comme les paniers Gobi sèchent très lentement, nous vous recommandons de ne pas les laisser sous la pluie. Notre assortiment ne comprend pas de protections.
Gobi-manden drogen erg traag. We raden je aan om ze niet buiten in de regen te laten staan. We bieden geen covers aan voor dit product.

LOFT RUGS

TAPIS EXTÉRIEURS - BUITENTAPIJTEN

PVC coated polyester
Polyester enduit de PVC
PVC gecoat polyester

*in stock
*en stock
*op stock

**on order - production time: 6 weeks
**sur commande - délai de production: 6 semaines
**op bestelling - productietijd: 6 weken

Rug Loft
Tapis Loft
Tapijt Loft

D2001-x

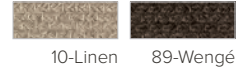

10-Linen 89-Wengé

€ 2.490	200x200cm**
€ 2.810	200x240cm**
€ 3.315	200x300cm**
€ 3.395	250x250cm**
€ 3.905	250x300cm**
€ 4.420	250x350cm**



SHINDI RUGS

TAPIS EXTÉRIEURS - BUITENTAPIJTEN

PVC coated polyester
Polyester enduit de PVC
PVC gecoat polyester

3D weaving
Tissage 3D
3D weaving

Rug Shindi
Tapis Shindi
Tapijt Shindi

D2003-x

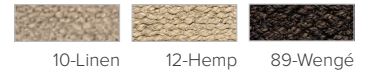

10-Linen 12-Hemp 89-Wengé

€ 2.935	200x200cm**
€ 3.450	200x250cm**
€ 3.955	200x300cm*
€ 5.425	200x350cm**
€ 5.550	200x450cm**
€ 5.550	300x300cm*
€ 7.530	300x400cm*



CUSTOMISED RUGS

TAPIS SUR MESURE - MAATWERK TAPIJTEN

670 €/M ²	Loft
790 €/M ²	Shindi

Maximum width 5m, unlimited length
Largeur maximale 5m, longueur illimitée
Maximale breedte 5m, lengte is onbeperkt

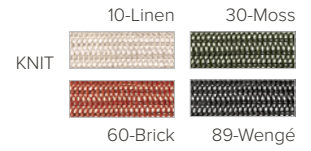

Removable knit in polyolefin rope
Tricot amovible en corde polyoléfine
Afnembaar breiwerk in polyolefine

LED lamp
Lampe LED
LED lamp

Monsieur Lebonnet



€ 1.040 Hanging 30cm
€ 1.175 Hanging 40cm
€ 1.655 Hanging 60cm

D080130H-xx

D080140H-xx

D080160H-xx

Madame Latoque



€ 1.040 Hanging 30cm
€ 1.175 Hanging 40cm

D080230H-xx

D080240H-xx

Madame Cachet



€ 1.040 Hanging 30cm
€ 1.175 Hanging 40cm
€ 1.310 Hanging 50cm

D080330H-xx

D080340H-xx

D080350H-xx

Monsieur Ellipse



€ 1.175 Hanging 40cm

D080440H-xx

Removable knit in polyolefin rope
Tricot amovible en corde polyoléfine
Afnembaar breiwerk in polyolefine

€ 445 PR80130-x Knit Monsieur Lebonnet 30cm/11.75"
€ 505 PR80140-x Knit Monsieur Lebonnet 40cm/15.75"
€ 700 PR80160-x Knit Monsieur Lebonnet 60cm/23.5"

€ 445 PR80230-x Knit Madame Latoque 30cm/11.75"
€ 505 PR80240-x Knit Madame Latoque 40cm/15.75"

€ 445 PR80330-x Knit Madame Cachet 30cm/11.75"
€ 505 PR80340-x Knit Madame Cachet 40cm/15.75"
€ 570 PR80350-x Knit Madame Cachet 50cm/19.75"

€ 445 PR80440-x Knit Monsieur Ellipse 40cm/15.75"

MONSIEUR TRICOT STANDING

ONTWERPSTUDIO MAISON TRICOT



111

Removable knit in polyolefin rope
Tricot amovible en corde polyoléfine
Afnembaar breiwerk in polyolefine

LED lamp
Lampe LED
LED lamp

On/Off switch
Bouton On/Off
Aan/Uit schakelaar

Rechargeable battery with USB slot
Batterie rechargeable avec port USB
Oplaadbare batterij met USB poort

Ceiling hook included
Crochet de plafond inclus
Plafondhaak inbegrepen

Monsieur Lebonnet
incl adapter



€ 1.040 Standing 30cm*
€ 1.175 Standing 40cm*
€ 1.655 Standing 60cm*

D080130S-xx

D080140S-xx

D080160S-xx

Madame Latoque
incl adapter



€ 1.040 Standing 30cm*
€ 1.175 Standing 40cm*

D080230S-xx

D080240S-xx

Madame Cachet
incl adapter



€ 1.040 Standing 30cm*
€ 1.175 Standing 40cm*
€ 1.310 Standing 50cm*

D080330S-xx

D080340S-xx

D080350S-xx

Removable knit in polyolefin rope
Tricot amovible en corde polyoléfine
Afnembaar breiwerk in polyolefine

€ 445 PR80130-x Knit Monsieur Lebonnet 30cm/11.75"
€ 505 PR80140-x Knit Monsieur Lebonnet 40cm/15.75"
€ 700 PR80160-x Knit Monsieur Lebonnet 60cm/23.5"

€ 445 PR80230-x Knit Madame Latoque 30cm/11.75"
€ 505 PR80240-x Knit Madame Latoque 40cm/15.75"

€ 445 PR80330-x Knit Madame Cachet 30cm/11.75"
€ 505 PR80340-x Knit Madame Cachet 40cm/15.75"
€ 570 PR80350-x Knit Madame Cachet 50cm/19.75"

€ 445 PR80440-x Knit Monsieur Ellipse 40cm/15.75"

MONSIEUR TRICOT STANDING WIRED

ONTWERPSTUDIO MAISON TRICOT

NEW

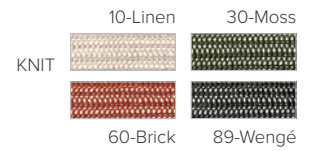

Removable knit in polyolefin rope
Tricot amovible en corde polyoléfine
Afneembaar breiwerk in polyolefine

LED lamp
Lampe LED
LED lamp

On/Off switch
Bouton On/Off
Aan/Uit schakelaar

Monsieur Lebonnet



€ 990 Standing 30cm*
€ 1.125 Standing 40cm*
€ 1.605 Standing 60cm*

D081130SW-xx

D081140SW-xx

D081160SW-xx

Madame Latoque



€ 990 Standing 30cm*
€ 1.125 Standing 40cm*

D081230SW-xx

D081240SW-xx

Madame Cachet



€ 990 Standing 30cm*
€ 1.125 Standing 40cm*
€ 1.260 Standing 50cm*

D081330SW-xx

D081340SW-xx

D081350SW-xx

Removable knit in polyolefin rope
Tricot amovible en corde polyoléfine
Afneembaar breiwerk in polyolefine

€ 445 PR80130-x Knit Monsieur Lebonnet 30cm/11.75"
€ 505 PR80140-x Knit Monsieur Lebonnet 40cm/15.75"
€ 700 PR80160-x Knit Monsieur Lebonnet 60cm/23.5"

€ 445 PR80230-x Knit Madame Latoque 30cm/11.75"
€ 505 PR80240-x Knit Madame Latoque 40cm/15.75"

€ 445 PR80330-x Knit Madame Cachet 30cm/11.75"
€ 505 PR80340-x Knit Madame Cachet 40cm/15.75"
€ 570 PR80350-x Knit Madame Cachet 50cm/19.75"

€ 445 PR80440-x Knit Monsieur Ellipse 40cm/15.75"

POUFS

Production time: 3 weeks
 Délai de production: 3 semaines
 Productietermijn: 3 weken



D € 550
 E € 655
 F € 775

Cover **D6021**
 Housse € 165
 Hoes



D € 675
 E € 775
 F € 895

Cover **D6022**
 Housse € 185
 Hoes

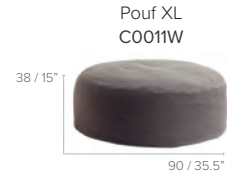

D € 910
 E € 1.015
 F € 1.140

Cover **D6023**
 Housse € 290
 Hoes

NOMAD POUFS

Production time: 3 weeks
 Délai de production: 3 semaines
 Productietermijn: 3 weken



D € 1.040
 E € 1.130
 F € 1.300

Cover **D5032**
 Housse € 185
 Hoes



D € 1.530
 E € 1.630
 F € 1.875

Cover **D5033**
 Housse € 290
 Hoes



D € 2.485
 E € 2.600
 F € 2.990

Cover **D5034**
 Housse € 355
 Hoes

MAI POUFS



12-Hemp



€ 2.795

Cover **D5582**
 Housse € 290
 Hoes



€ 1.945

Cover **D5584**
 Housse € 210
 Hoes

DECO CUSHIONS

COUSSINS DE DÉCORATION - DECOKUSSENS



Scatter cushions
Coussins de décoration
Decokussen



Scatter cushions with piping
Coussins de décoration avec passepoil
Decokussen met bies



Box cushions
Coussins plate-bande
Decokussen met boord

	ART. NR.	DIMENSIONS	COLLECTION	cat D	cat E	cat F
SCATTER CUSHIONS	C0001-x	40x40cm		€ 120	€ 150	€ 180
	C0002-x	50x50cm		€ 155	€ 185	€ 210
	C0003-x	60x60cm		€ 190	€ 215	€ 240
	C0013-x	50x30cm	Tosca	€ 100	€ 120	€ 140
	C0016-x	75x75cm		€ 255	€ 305	€ 375
	C01712B-x	49x30cm	Vis à Vis lounge chair	€ 115	€ 130	€ 140
	C01713B-x	42,5x31,5cm	Vis à Vis rocking chair	€ 115	€ 130	€ 140
	C01718B-x	56x43cm	Vis à Vis armchair	€ 115	€ 130	€ 140
DECO + PIPING	C0001P-x-y	40x40cm		€ 155	€ 185	€ 210
	C0002P-x-y	50x50cm		€ 185	€ 220	€ 255
	C0003P-x-y	60x60cm		€ 220	€ 265	€ 315
	C0013P-x-y	50x30cm	Tosca	€ 140	€ 155	€ 185
	C01712BP-x-y	49x30cm	Vis à Vis lounge chair	€ 145	€ 170	€ 200
	C01713BP-x-y	42,5x31,5cm	Vis à Vis rocking chair	€ 140	€ 165	€ 195
	C01718BP-x-y	56x43cm	Vis à Vis armchair	€ 140	€ 165	€ 200
BOX CUSHIONS	C0004-x	55x35x8cm		€ 160	€ 185	€ 205
	C0012-x	63x45x15cm	Vis à Vis sofa	€ 345	€ 430	€ 480
	C06218B-x	40x25x13cm	Mood lumbar	€ 95	€ 115	€ 135
	C06218BH-x	38x38x13cm	Mood high back	€ 135	€ 170	€ 190
	C02300-x	68x45x15cm	Senja casual back	€ 350	€ 430	€ 480

x = Color of the fabric, determines the price category
Couleur du tissu, détermine la catégorie de prix
Kleur van de stof, bepaalt de prijscategorie

y = Piping color, only available in the following colors:
Couleur de la passepoile, seulement disponible dans les couleurs suivantes:
Kleur van de piping, enkel beschikbaar in volgende kleuren:

y - Piping - Passepoil - Bies

01 Natté White	NEW	47 Natté Ochre	E103 Linen Mushroom	NEW
05 Natté Poivre	NEW	76 Granite	E107 Linen Dark Blue	NEW
42 Leaf		E81 Linen	E108 Linen Frost Blue	NEW
45 Natté Mist		E82 Linen White Sand	E111 Linen Verdant Grey	NEW

Head support lounger
Repose tête chaise longue
Hoofdsteun ligbed

C0006W



€ 245 cat D
€ 265 cat E
€ 295 cat F

Head support lounger round
Repose tête chaise longue ronde
Hoofdsteun ligbed rond

C0005W



€ 200 cat D
€ 240 cat E
€ 280 cat F

C0005 can be combined with Nodi, Kos, Forum and Ukiyo loungers.
C0005 peut être combiné avec les chaises longues Nodi, Kos, Forum et Ukiyo.
C0005 kan gecombineerd worden met de Nodi, Kos, Forum en Ukiyo ligbedden.

FABRIC

TISSU - STOF

130 €/m cat D
250 €/m cat E
310 €/m cat F

Fabric per running meter only as part of an existing order and limited to a maximum of 5 meters
Tissu par mètre linéaire uniquement dans le cadre d'une commande existante et limité à un maximum de 5 mètres
Stof per meter enkel als onderdeel van een bestaande bestelling en beperkt tot een maximum van 5 meter

Maintenance products teak
 Produits d'entretien teck
 Onderhoudsproducten teak

Teak Super Cleaner
 500 ml

€ 25

D9914



Teak Protector Grey Colour
 500 ml

€ 30

D9912



Teak Sealer Natural
 1000 ml

€ 160

D9959



Maintenance products stainless steel
 Produits d'entretien inox
 Onderhoudsproducten Inox

Stainless Steel Super Cleaner
 (CB & EP)
 250 ml

€ 40

D9918



Maintenance products aluminium & powdercoated stainless steel
 Produits d'entretien aluminium & inox laqué par poudrage
 Onderhoudsproducten aluminium & gepoederlakt aluminium

Coated aluminium & stainless steel Cleaner
 500 ml

€ 35

D9952



Coated aluminium &
 stainless steel Protector
 500ml

€ 45

D9931



Coated aluminium & stainless steel Protector
 500ml

€ 45

D9931



Maintenance products granite
 Produits d'entretien granit
 Onderhoudsproducten graniet

Granite Cleaner/Protector
 500 ml

€ 80

D9961



Maintenance products fabrics + CTR, Elio, Mood, Regista & Tosca
 Produits d'entretien tissus + CTR, Elio, Mood, Regista & Tosca
 Onderhoudsproducten stoffen + CTR, Elio, Mood, Regista & Tosca

Textile Protector
 500 ml

€ 45

D9924



Maintenance products synthetic material
 Produits d'entretien matière synthétique
 Onderhoudsproducten synthetisch materiaal
 (Batyline®, Canax®, Sunscape, CTR, Elio, Mood, Nodi & Tosca weave)

Synthetics Super Cleaner D9922
 500 ml

€ 35



Synthetics Protector D9921
 500 ml

€ 30



Maintenance products ceramic and glazed lava stone
 Produits d'entretien céramique et pierre de lave émaillée
 Onderhoudsproducten keramiek en geglazuurde lavasteen

Ceramic, Lava Stone & Glass Cleaner D9938
 500 ml

€ 35



Ceramic, Lava Stone & Glass Protector D9955
 100 ml

€ 35



Maintenance products travertine

Travertine Conditioner D9967
 250ml

€ 55

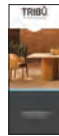

Maintenance products lightened concrete
 Produits d'entretien béton allégé
 Onderhoudsproducten verlicht beton

Lightened Concrete Conditioner D9962
 500 ml

€ 90



Oil, Wax & Grease remover D9963
 250 ml

€ 90



Sanding Disc HT013

€ 10



Lightened Concrete Care Set D9964
 Kit soins pour béton allégé
 Verlicht Beton Care set

€ 195

D9962 + D9963 + HT013 + Brush/Brosse/Borstel + Microfiber cloth/Chiffon en microfibre/Microvezeldoek

Correctors
 Correcteurs
 Correctors

D9933P	Paint pen aluminium white	8 ml	€ 30
D9943P	Paint pen aluminium wengé	8 ml	€ 30
D9955P	Paint pen aluminium linen	8 ml	€ 30
D9968P	Paint pen aluminium clay	8 ml	€ 30
D9956-xx	Aluminium corrector (00-white, 10-linen, 20-clay, 89-wengé)	12ml	€ 35

Microfiber cloth D9935
 Chiffon en microfibre
 Microvezeldoek

€ 6

40x40cm









LOW TABLES OVERVIEW

TABLES BASSES - LAGE TAFELS









ROUND TABLES

Tables basses rondes – Lage ronde tafels

			Ø 32 Ø 12.5"	Ø 35 Ø 13.75"	Ø 40 Ø 15.75"	Ø 48 Ø 19"	Ø 50 Ø 19.75"	Ø 60 Ø 23.5"	Ø 80 Ø 31.5"	Ø 85 Ø 33.5"	Ø 90 Ø 35.5"	Ø 125 Ø 49.25"
AMANU		H28 - H11"									02684L	02686L
		H35 - H13.75"									02684M	02686M
		H42 - H16.5"									02684H	02686H
DROPS		H30 - H11.75"			D5026			D5027				
		H40 - H15.75"										
		H50 - H19.75"										
DUNES		H50 - H19.75"				D8300						
		H40 - H15.75"						D8302				
MARE		H40 - H15.75"	04560			04580						
		H50 - H19.75"										
NATAL ALU X		H45 - H17.75"		06176								
OTTO		H45 - H17.75"				04280		04282				
		H32 - H12.5"				04281		04283			04284	
T-TABLE		H35 - H13.75"							D2168		D2164	D2165

SQUARE TABLES

Tables basses carrées – Lage vierkante tafels







			40x40 15.75x15.75"	42x45 16.5x17.75"	48x54 19x21.25"	58x58 22.75x22.75"	60x60 23.5x23.5"	66x66 26x26"	80x80 31.5"x31.5"	90x90 35.5"x35.5"	99x99 39x39"	102x102 40.25"	121x121 47.75x47.75"
KOS		H25 H9.75"		04090									
MOOD		H28 H11"						06282					
NATAL ALU X		H35 H13.75"	06180				06182						
SEREN		H39 H15.25"				02882							
		H46 H18"				02884							
TAO		H37 H14.5"							01682				
T-TABLE		H35 H13.75"								D2173			
TOSCA		H49,5 H19.5"			05381								
UKIYO		H36 14.25"										07586	
VIS A VIS		H18 H7"									01781		01786

LOW TABLES OVERVIEW

TABLES BASSES - LAGE TAFELS

RECTANGULAR TABLES

Tables basses rectangulaires – Lage rechthoekige tafels

			120x66 47,25x26"	98x86 38.5x33.75"	121x99 47.75x39"	150x100 59x39.25"	159x44 62,5x17,25	160x70 63x27.5"	240x98 94.5x38.5"	298x98 117.25x38.5"
MOOD		H28 H11"	06284							
SEREN		H32 H12.5"				02886				
T-TABLE		H35 H13.75"							D2178	D2179
TOSCA		H31,5 H12.5"		05386						
UKIYO		H36 14.25"						07588		
VIS A VIS		H18 H7"			01784		01732			

MISCELLANEOUS

Divers – Varia









			105x81cm 41.25x32"	140x107 55x42.25"	30x30 11.75x11.75"	35x40 13.75x15.75"	Ø 44 Ø 17.25"	Ø 50 Ø 19,75"	Ø 69 Ø 27.25"
AMANU C-TABLE TEAK		H50 H19.75"					02685		
PURE C-TABLE TEAK		H48 H19"				01285			
DUNES		H32 H12.5"	D8305	D8306					
ROOTS		H40 H15.75"			D8102				
TAIRU		H40 H15.75"			D8103				
HEXAGON		H31 H12.25"							D5040
		H49 H19.25"						D5041	

DINING TABLES - OVERVIEW BY SIZE

TABLES À MANGER - EETTAfels









BISTRO / BALCONY TABLES

Tables bistro/balcon - Bistro/Balcon tafels

		 2 SEATS	 2+2 SEATS
BRANCH		07671 80x80 31.5x31.5"	07670 90x90 35.5x35.5"
ILLUM			06573 100x100 39.5x39.5"
ILLUM TEAK			06573-T 100x100 39.5x39.5"
KOS			04073 98x98 38.5x38.5"
T-TABLE			D2170 90x90 35.5x35.5"
T-TABLE LOW DINING			D2172 90x90 35.5x35.5"
VIS A VIS			01773 99x99 39x39"

ROUND TABLES

Tables rondes - Ronde tafels

		 3 SEATS	 4 SEATS	 6 SEATS	 7 SEATS
BRANCH		07660 Ø80 Ø31.5"	07662 Ø 125 cm Ø 49.25"		
OTTO DINING + LOW DINING				04266 Ø 148 cm Ø58,25" 04267 Ø 148 cm Ø58,25"	
T-TABLE		D2166 Ø80 Ø31.5"	D2160 Ø90 Ø35.5" D2162 Ø 125 cm Ø 49.25"		
T-TABLE LOW DINING		D2167 Ø80 Ø31.5"	D2161 Ø90 Ø35.5" D2163 Ø 125 cm Ø 49.25"		
TAO				01666 Ø 160 cm Ø 63"	01668 Ø 180 cm Ø 71"

* This guide is based on an average chair width of 55cm/21.75".

* Ce guide est basé sur une largeur de chaise moyenne de 55cm/21.75".

















* Deze gids is gebaseerd op een gemiddelde stoelbreedte van 55cm/21.75".

DINING TABLES - OVERVIEW BY SIZE

TABLES À MANGER - EETTAfels

RECTANGULAR TABLES

Tables rectangulaires - Rechthoekige tafels







		 4 SEATS	 4+2 SEATS	 6+2 SEATS	 8+2 SEATS	 10+2 SEATS	 12+2 SEATS	 14+2 SEATS	 16+2 SEATS
AMANU					02652 290x98 114.25x38.5"	02654 350x98 137.75x38.5"			
BRANCH				07652 210x98 82.75x38.5"	07654 300x110 118x43.25"				
ILLUM			06550 152x100 60x39.5"	06552xs 212x71 83.5x28" 06552 212x100 83.5x39.5"	06554xs 267x71 105x28" 06554 267x100 105x39.5"				
ILLUM TEAK			06550-T 152x100 60x39.5"	06552xs-T 212x73 83.5x28.75" 06552-T 212x100 83.5x39.5"	06554-T 267x100 105x39.5"				
KOS				04052 224x100 88x39.5"	04053 266x100 104.75x39.5" 04054 308x110 121.25x39.5"				
LUCCA				03252 240x110 94.5x43.25"	03254 320x125 126x49.25"				
NOX					02252 264x99 104x39" 02254 352x99 138.5x39"				
OTTO					04254 320x110 126x43.25" 04253 290x110 114.25x43.25"				
SURO				02752 210x110 82.75x43.25"	02753 280x110 110.25x42.25"	02754 420x110 165.35x42.25"	02755 490x110 192.91x42.25"	02756 560x110 220.47x42.25"	02757 630x110 248.03x42.25"
T-TABLE		D2183 136x80 53.54x31.5"			D2175 240x98 94.5x38.5"	D2176 298x98 117.25x38.5"			
T-TABLE LOW DINING		D2184 136x80 53.54x31.5"			D2177 240x98 94.5x38.5"	D2178 298x98 117.25x38.5"			
TAO				01670 120x240cm 47.25x94.5"					
TOSCA				05355 240x98 94.5x38.5"	05354 298x98 117.25x38.5"				
UKIYO					07553 271x104 106.75x41"				
VIS A VIS					01753 300x99 118x39"	01754 400x99 157.5x39"	01755 500x99 197x39"	01756 600x99 236.25x39"	01757 700x99 275.5x39"

DINING TABLES - OVERVIEW BY MATERIALS

TABLES À MANGER - EETTAfels

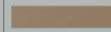
CHOOSE YOUR FRAME







Choisissez votre cadre - Kies uw frame

	POWDERCOATED METAL MÉTAL LAQUÉ PAR POWDRAGE GEPOEDERLAKT METAAL				TEAK TECK TEAK	CONCRETE BÉTON BETON	
	00-White	10-Linen	20-Clay	89-Wengé		10-Linen	89-Wengé
							
AMANU					X		
BRANCH	X	X		X			
ILLUM	X	X		X	X		
KOS					X		
LUCCA		X	X	X			
NOX	X	X		X			
OTTO					X		
SURO			X		X		
TAO						X	X
TOSCA		X		X			
T-TABLE	X	X	X	X			
UKIYO					X		
VIS-À-VIS					X		

CHOOSE YOUR TABLETOP

Choisissez votre dessus de table – Kies uw tafelblad

	ALUMINIUM			TEAK TECK TEAK	CERAMIC CÉRAMIQUE KERAMIEK						
	00-White	10-Linen	89-Wengé		10-Linen	11-Cienna	15-Sabbia	76-Pebble	80-Scisto	86-Pompei	89-Piombo
											
AMANU							X		X		
BRANCH	X	X	X	X							
ILLUM				X	X		X				X
ILLUM TEAK				X	X		X				X
KOS				X							
LUCCA						X		X		X	
NOX							X		X		
OTTO							X		X		
SURO				X							
TOSCA					X		X		X		X
T-TABLE				X	X		X		X		X
UKIYO				X	X		X		X		X
VIS-à-VIS				X							

	GLAZED LAVA STONE PIERRE DE LAVE ÉMAILLÉ GEËMAILLEERDE LAVASTEEN				CONCRETE BÉTON BETON		TRAVERTINE TRAVERTIN
	L10-Linen	L30-Moss	L70-Ocean	L89-Wengé	10-Linen	89-Wengé	TV-Travertine
							
NOX	X	X	X				
OTTO							X
T-TABLE	X	X		X			
TAO					X	X	

COVERS FOR SOFA'S

Custom covers = 165€ per single seat and 330€ for meridienne and daybed modules. You will receive 1 cover, that is made exactly to the size of your modular sofa.

Housses sur mesure = 165€ par siège simple et 330€ pour les modules méridienne et daybed. Vous recevrez 1 housse, qui est faite exactement à la taille de votre canapé modulaire.

Covers op maat = 165€ per enkele zitplaats en 330€ voor meridienne en daybed modules. U ontvangt 1 hoes, die precies op maat van uw modulaire Sofa wordt gemaakt.

NATAL ALU SOFA



NODI SOFA

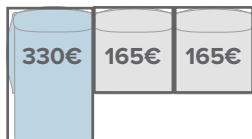

PURE SOFA



SENJA SOFA

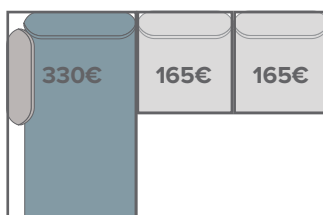

VIS À VIS SOFA

Covers cover only the cushions, not the borders or tables. In case you order a high back cushion, please indicate the position on your set.

Les housses couvrent uniquement les coussins, pas les bords ou les tables. Si vous commandez un coussin de dossier élevé, veuillez indiquer sa position sur votre set.

De hoezen bedekken enkel de kussens, niet de boorden of tafels. Indien u een high back kussen bestelt, gelieve de positie ervan aan te duiden op uw set.



HOUSES POUR TABLES À MANGER - HOEZEN VOOR EETTAfels

Covers in PU-breathable material. Colour grey.

Housses de protection en PU respirant. Couleur gris.

Beschermhoezen in ademend PU. Kleur grijs.

Protection against dirt, not 100% waterproof

Protection contre les saletés, n'est pas 100% imperméable à l'eau

Vuilwerend, niet 100% waterdicht

COLLECTIONS	ART. NR.	TABLE DIMENSIONS	A	B	C
AMANU	D7290-100-A/B/C D7350-100-A/B/C	290 x 98cm 114.25 x 38.5" 350 x 98cm 137.75 x 38.5"	€ 585 € 645	€ 690 € 765	€ 830 € 915
BRANCH	D7080-A/C	Dia80cm Dia31.5"	€ 315		€ 430
	D7125-A/C	Dia125cm Dia49.25"	€ 405		€ 520
	D7080-80-A/B/C	80 x 80cm 31.5 x 31.5"	€ 315	€ 375	€ 480
	D7090-90-A/B/C	90 x 90cm 35.5 x 35.5"	€ 340	€ 410	€ 490
	D7210-98-A/B/C	210 x 98cm 82.75 x 38.5"	€ 475	€ 570	€ 760
	D7300-110-A/B/C	300 x 110cm 118 x 43.25"	€ 655	€ 785	€ 875
ILLUM	D7210-71-A/B/C	212 x 71cm 83.5 x 28"	€ 450	€ 545	€ 760
	D7210-73-A/B/C	212 x 73cm 83.5 x 28.75"	€ 450	€ 545	€ 760
	D7265-71-A/B/C	267 x 71cm 105 x 28"	€ 610	€ 725	€ 850
	D7100-100-A/B/C	100 x 100cm 39.5 x 39.5"	€ 375	€ 450	€ 495
	D7152-100-A/B/C	152 x 100cm 60 x 39.5"	€ 385	€ 465	€ 580
	D7210-98-A/B/C D7265-98-A/B/C	212 x 100cm 83.5 x 39.5" 267 x 100cm 105 x 39.5"	€ 475 € 630	€ 570 € 760	€ 760 € 850
ILLUM COUNTERHEIGHT	D6560-100-A/B/C	152 x 100cm 60 x 39.5"	€ 480	€ 565	€ 705
	D6564-71-A/B/C	212 x 71cm 83.5 x 28"	€ 480	€ 565	€ 705
KOS	D7100-100-A/B/C	98 x 98cm 38.5 x 38.5"	€ 375	€ 450	€ 495
	D7223-100-A/B/C	224 x 100cm 88 x 39.5"	€ 485	€ 590	€ 785
	D7265-100-A/B/C	266 x 100cm 104.75 x 39.5"	€ 630	€ 760	€ 860
	D7300-110-A/B/C	308 x 110cm 121.25 x 43.25"	€ 655	€ 785	€ 875
LUCCA	D7240-110-A/B/C	240 x 110cm 94.5 x 43.25"	€ 500	€ 600	€ 790
	D7320-125-A/B/C	320 x 125cm 126 x 49.25"	€ 660	€ 790	€ 880
NOX	D7265-100-A/B/C	264 x 99cm 104 x 39"	€ 630	€ 760	€ 860
	D7360-100-A/B/C	352 x 99cm 138.5 x 39"	€ 725	€ 875	€ 1.100
OTTO DINING	D7148-A/C	Dia 148cm 58.25"	€ 395		€ 500
	D7290-110-A/B/C	290 x 110cm 114.25 x 43.25"	€ 585	€ 690	€ 830
	D7320-110-A/B/C	320 x 110cm 126 x 43.25"	€ 675	€ 805	€ 895
SURO	D7210-110-A/B/C	210 x 110cm 82.75 x 43.25"	€ 475	€ 570	€ 760
	D7280-110-A/B/C	280 x 110cm 110.25 x 43.25"	€ 650	€ 755	€ 855
	D7420-110-A/B/C	420 x 110cm 165.25 x 43.25"	€ 730	€ 880	€ 1.105
	D7490-110-A/B/C	490 x 110cm 193 x 43.25"	€ 915	€ 1.100	€ 1.465
	D7560-110-A/B/C	560 x 110cm 220.5 x 43.25"	€ 1.200	€ 1.445	€ 1.740
	D7630-110-A/B/C	630 x 110cm 248 x 43.25"	€ 1.320	€ 1.465	€ 1.860
T-TABLE	D7080-75-A/C	Dia80cm Dia31.5"	€ 315		€ 430
	D7090-75-A/C	Dia90cm Dia35.5"	€ 340		€ 360
	D7125-75-A/C	Dia125cm Dia49.25"	€ 355		€ 465
	D7090-90-A/B/C	90 x 90cm 35.5 x 35.5"	€ 340	€ 410	€ 490
	D7240-98-A/B/C	240 x 98cm 94.5 x 38.5"	€ 500	€ 600	€ 796
	D7298-98-A/B/C	298 x 98cm 117.25 x 38.5"	€ 655	€ 785	€ 875
	D7136-80-A/B/C	136 x 80cm 53.54 x 31.5"	€ 390	€ 400	€ 480
TAO	D1666-75-A/C	Dia160cm Dia63"	€ 545		€ 565
	D1668-75-A/C	Dia180cm Dia71"	€ 565		€ 595
	D1670-75-A/B/C	120x240cm 47.25x-94.5"	€ 500	€ 600	€ 796
TOSCA	D7240-98-A/B/C	240 x 98cm 94.5 x 38.5"	€ 500	€ 600	€ 796
	D7300-98-A/B/C	298 x 98cm 117.25 x 38.5"	€ 655	€ 785	€ 875
UKIYO	D7271-104-A/B/C	271 x 104cm 106.69 x 40.94"	€ 535	€ 635	€ 760
VIS-À-VIS	D7099-99-A/B/C	99 x 99cm 39 x 39"	€ 350	€ 415	€ 480
	D7300-99-A/B/C	300 x 99cm 118 x 39"	€ 655	€ 785	€ 875
	D7400-99-A/B/C	400 x 99cm 157.5 x 39"	€ 725	€ 875	€ 1.100
	D7500-99-A/B/C	500 x 99cm 197 x 39"	€ 915	€ 1.100	€ 1.465
	D7600-99-A/B/C	600 x 99cm 236.25 x 39"	€ 1.220	€ 1.465	€ 1.760
	D7700-99-A/B/C	700 x 99cm 275.5 x 39"	€ 1.470	€ 1.760	€ 1.890

A

A: Cover for table only.
Housse pour la table uniquement.
Hoes voor enkel tafel.

B: Cover for table with chairs. Please specify the type of chairs when ordering.
Housse pour table avec chaises. Veuillez spécifier quelles chaises lorsque vous passez à la commande.
B: Hoes voor tafel met stoelen. Gelieve het type stoel te vermelden bij uw order.

COVERS FOR LOW DINING TABLES

HOUSES POUR TABLES À MANGER BASSES - HOEZEN VOOR LAGE EETTAfels

COLLECTIONS	ART. NR.	TABLE DIMENSIONS	A	B	C
OTTO LOW DINING - H64cm	D7148-64-A/C	Dia 148cm H64cm	€ 395		€ 500
T-TABLE LOW DINING - H64cm	D7080-64-A/C	Dia80cm Dia31.5"	€ 315		€ 380
	D7090-64-A/C	Dia90cm Dia35.5"	€ 340		€ 410
	D7125-64-A/C	Dia125cm Dia49.25"	€ 315		€ 480
	D7090-90-64-A/B/C	90 x 90cm 35.5 x 35.5"	€ 340	€ 410	€ 490
	D7240-98-64-A/B/C	240 x 98cm 94.5 x 38.5"	€ 500	€ 600	€ 796
	D7298-98-64-A/B/C	298 x 98cm 117.25 x 38.5"	€ 655	€ 785	€ 875
T-TABLE LOW DINING - H67cm	D7136-80-64-A/B/C	136x80cm 53.54 x 31.5"	€ 390	€ 400	€ 480
	D7080-67-A/C	Dia80cm Dia31.5"	€ 315		€ 430
	D7090-67-A/C	Dia90cm Dia35.5"	€ 340		€ 450
	D7125-67-A/C	Dia125cm Dia49.25"	€ 345		€ 465
	D7090-90-67-A/B/C	90 x 90cm 35.5 x 35.5"	€ 340	€ 410	€ 490
	D7240-98-67-A/B/C	240 x 98cm 94.5 x 38.5"	€ 500	€ 600	€ 796
TOSCA LOW DINING - H67cm	D7298-98-67-A/B/C	298 x 98cm 117.25 x 38.5"	€ 655	€ 785	€ 875
	D7240-98-67-A/B/C	240x98x67cm 94.5 x 38.5"	€ 500	€ 600	€ 796



- C:** Cover for table with chairs at the side and head of the table. Please specify the type of chairs when ordering.
C: Housse pour table avec chaises sur les côtés et à la tête de la table. Veuillez spécifier quelles chaises lorsque vous passez à la commande.
C: Hoes voor tafel met stoelen aan de zijkant en op de koppen. Gelieve het type stoel te vermelden bij uw order.

COVERS FOR LOW TABLES

HOUSES POUR TABLES BASSES - HOEZEN VOOR LAGE TAFELS

Covers in PU-breathable material. Colour grey.

Housses de protection en PU respirant. Couleur gris.

Beschermhoezen in ademend PU. Kleur grijs.

Protection against dirt, not 100% waterproof

Protection contre les saletés, n'est pas 100% imperméable à l'eau

Vuilwerend, niet 100% waterdicht

COLLECTIONS	ART. NR.	ART. NR. COVER	TABLE DIMENSIONS	A
AMANU	02684L	D2684L	Dia 90 x H28cm Dia 35.5 x 11"	€ 220
	02684M	D2684M	Dia 90 x H35cm Dia 35.5 x 13.75"	€ 250
	02684H	D2684H	Dia 90 x H42cm Dia 35.5 x 16.5"	€ 275
	02686L	D2686L	Dia 125 x H28cm Dia 49.25 x 11"	€ 290
	02686M	D2686M	Dia 125 x H35cm Dia 49.25 x 13.75"	€ 330
	02686H	D2686H	Dia 125 x H42cm Dia 49.25 x 16.5"	€ 355
	02688L	D2688L	155 x 58 x H28cm 61 x 22.75 x 11"	€ 230
	02688M	D2688M	155 x 58 x H35cm 61 x 22.75 x 13.75"	€ 245
	02688H	D2688H	155 x 58 x H42cm 61 x 22.75 x 16.5"	€ 260
	02685	D2685	Dia 44 x H50cm Dia 17.25 x H19.75"	€ 155
DROPS	D5026	D5030	Dia40 x H 30cm Dia15.75 x H12.25"	€ 160
	D5027	D5031	Dia60 x H 30cm Dia23.5 x H12.25"	€ 175
DUNES	D8300	D8301	Dia48 x H50cm Dia19 x H19.75"	€ 155
	D8302	D8303	Dia60 x H40cm Dia23,5 x H15.75"	€ 145
HEXAGON	D5040	D5042	Dia69xH31cm Dia27.25 x H12.25"	€ 160
	D5041	D5043	Dia50xH49cm Dia19.75 x H19.25"	€ 160
KOS	04090	D6095	42 x 45 x H25cm 16.5 x 17.75 x H10"	€ 115
MARE	04560 - H40	D4560	Dia 32 x H40cm 12.5 x H15.75"	€ 160
	04560 - H50	D4561	Dia 32 x H50cm 12.5 x H19.75"	€ 170
	04580 - H40	D4580	Dia 48 x H40cm 19 x H15.75"	€ 175
	04580 - H50	D4581	Dia 48 x H50cm 19 x H19.75"	€ 185
MOOD	06282	D6096	66 x 66 x H28cm 26x26xH11"	€ 125
	06284	D6108	120 x 66 x H28cm 47.25x26xH11"	€ 185
NATAL ALU	06176	D6176	Dia35 x H45cm Dia13.75 x H17.75"	€ 145
	06180	D6180	40 x 40 x H35cm 15.75 x 15.75 x H13.75"	€ 165
	06182	D6182	60 x 60 x H35cm 23.5 x 23.5 x H13.75"	€ 180
OTTO	04280	D4280	Dia 48cm x H45cm Dia 19 x H17.75"	€ 155
	04281	D4281	Dia 48cm x H32cm Dia 19 x H12.6"	€ 150
	04282	D4282	Dia 60cm x H45cm Dia 23.5 x 17.75"	€ 165
	04283	D4283	Dia 60cm x H32cm Dia 12.5 x 12.6"	€ 160
	04284	D4284	Dia 90cm x H32cm Dia 35.5 x 12.6"	€ 255
PURE	01285	D6123	42 x 37 x H48cm 16.53 x 14.56 x 18.89"	€ 125
ROOTS	D8102	D8101S - Standing D8101L - Lying	30 x 30 x H40cm 11.75 x 11.75 x H15.75"	€ 125 € 125
SEREN	02882	D2882	58 x 58 x H39cm 22.75 x 22.75 x H15.25"	€ 190
	02884	D2884	58 x 58 x H46cm 22.75 x 22.75 x H18"	€ 210
	02886	D2886	150 x 100 x H32cm 59 x 39.25 x H12.5"	€ 380
TAIRU	D8103	D8101S	30 x 30 x H40cm 11.75 x 11.75 x H15.75"	€ 125
T-TABLE	D2168	D7080	Dia80 x H35cm Dia31.5 x H13.75"	€ 225
	D2164	D7090	Dia90 x H35cm Dia35.5 x H13.75"	€ 250
	D2165	D7125	Dia125 x H35cm Dia49.25 x H13.75"	€ 330
	D2174	D7090-90-35	90 x 90 x H35cm 35.5 x 35.5 x H13.75"	€ 255
	D2179	D7240-98-35	240 x 98 x H35cm 94.5 x 38.5 x H13.75"	€ 425
	D2180	D7298-98-35	298 x 98 x H35cm 117.25 x 38.5 x H13.75"	€ 560
	D2185	D7136-80-35	136 x 80 x H35cm 53.54 x H31.5 x H13.75"	€ 360
TAO	01682	D1682	Dia80 x H37cm Dia31.5 x H14.5"	€ 355
TOSCA	05381	D5381	54 x 48 x H49,5cm 21.25 x 19 x H19,5"	€ 140
	05386	D5386	98 x 86 x H31,5cm 38.5 x 33.75 x H12,5"	€ 230
UKIYO	07586	D7586	102 x 102 x 36cm 40.16 x 40.16 x H14.17"	€ 345
	07588	D7588	160 x 70 x 36 cm 63 x 27.56 x H14.17"	€ 245
VIS-À-VIS	01781	D1781	99 x 99 x H18cm 39 x 39 x H7"	€ 140
	01784	D1784	121 x 99 x H18cm 47.75 x 39 x H7"	€ 165
	01786	D1786	121 x 121 x H18cm 47.75 x 47.75 x H7"	€ 220

TECHNICAL STANDARDS

NORMES TECHNIQUES - TECHNISCHE NORMEN

A perfect quality is the cornerstone of Tribù's company philosophy. This is guaranteed by a careful selection of the most durable materials, a long term cooperation with industrial partners, each an expert in their field, and a rigorous testing of our models in compliance to both EU and USA standards.

BIFMA X5- RANGE

BIFMA (Business and Institutional Furniture Manufacturers Association) is an American standard that sets the acceptance levels and test parameters for evaluating the safety, durability and structural adequacy of contract furniture.

EN 581-1:2006

A EU standard that specifies the general safety requirements for seating and tables.

EN 1728:2012

A EU standard that specifies the mechanical requirements (strength and stability) and test methods for furniture seating.

EN 1022:2005 6

A EU standard that measures the stability of domestic furniture.

CPSD-HL-01012-MTHD

Measures the effect of extreme temperature change (24hrs at -17°C/0 °F and 48°C/120°F).

CPSD-HL-01063-MTHD

Measures the moisture content of wood, which should be between 8 and 12%.

CPSD-HL-01010-MTHD/ASTM B117-11

Measures the resistance to corrosion of metal parts.

AATCC 16

Measures the colourfastness to light.

AATCC106

Measures the colourfastness to sea water.

AATCC162

Measures the colourfastness to chlorinated pool water.

ASTM B117-11

Tests the corrosion resistance of coated metals in a controlled atmosphere.

La philosophie de l'entreprise Tribù repose sur une qualité parfaite que nous garantissons en sélectionnant soigneusement les matériaux les plus résistants et en collaborant avec des partenaires industriels fixes, chacun expert dans son domaine. En outre, nous soumettons nos modèles à des tests rigoureux en conformité aux normes de l'UE et USA.

BIFMA X5- RANGE

BIFMA (Business and Institutional Furniture Manufacturers Association) est une norme américaine qui fixe les niveaux d'acceptation et les paramètres d'essai test pour évaluer la sécurité, la durabilité et l'adéquation structurelle de meubles pour le secteur du contrat.

EN 581-1:2006

Une norme européenne qui spécifie les exigences générales de sécurité des sièges et des tables.

EN 1728:2012

Une norme européenne qui spécifie les exigences mécaniques (résistance et stabilité) et méthodes d'essai pour les sièges.

EN 1022:2005 6

Une norme européenne qui mesure la stabilité du mobilier domestique .

CPSD-HL-01012-MTHD

Mesure l'effet des températures extrêmes (24hrs à -17°C et 48°C).

CPSD-HL-01063-MTHD

Mesure la teneur en humidité du bois. Ceci devrait être compris entre 8 et 12 %.

CPSD-HL-01010-MTHD/ASTM B117-11

Mesure la résistance à la corrosion des pièces métalliques.

AATCC 16

Mesure la solidité des couleurs à la lumière.

AATCC106

Mesure la solidité des couleurs à l'eau de mer.

AATCC162

Mesure la solidité des couleurs à l'eau de piscine chlorée.

ASTM B117-11

Teste la résistance à la corrosion des métaux laqués dans une atmosphère contrôlée.

Een perfecte kwaliteit is de hoeksteen van Tribù's bedrijfsfilosofie. Deze kwaliteit wordt gegarandeerd door een zorgvuldige selectie van de meest duurzame materialen, een lange termijn samenwerking met industriële partners, elk expert in hun gebied, en het uitgebreid testen van onze modellen om te voldoen aan zowel EU als VS-normen.

BIFMA X5- RANGE

BIFMA (Business and Institutional Furniture Manufacturers Association) is een Amerikaanse norm die de aanvaardingniveaus en testparameters vastlegt voor het evalueren van de veiligheid, duurzaamheid en structurele adequaatheid van projectmeubilair.

EN 581-1:2006

Een EU norm die de algemene veiligheidsvereisten vastlegt voor zitmeubelen en tafels.

EN 1728:2012

Een EU norm die de mechanische vereisten (sterkte en stabiliteit) en

testmethodes vastlegt voor zitmeubelen.

EN 1022:2005 6

Een EU norm die de stabiliteit meet van meubelen voor huishoudelijk gebruik.

CPSD-HL-01012-MTHD

Meet het effect van extreme temperaturen (24u aan -17°C en 48°C).

CPSD-HL-01063-MTHD

Meet het vochtgehalte van hout dat tussen de 8 en 12% moet zijn.

CPSD-HL-01010-MTHD/ASTM B117-11

Meet de corrosiebestendigheid van metalen onderdelen.

AATCC 16

Meet de kleurvastheid bij blootstelling aan licht.

AATCC106

Meet de kleurvastheid bij blootstelling aan zeewater.

AATCC162

Meet de kleurvastheid bij blootstelling aan zwembadwater met chloor.

ASTM B117-11

Test de corrosie van gecoate metalen in een gecontroleerde atmosfeer.

TECHNICAL STANDARDS CHAIRS

NORMES TECHNIQUES - TECHNISCHE NORMEN

AMANU (p. 8)
loung chair

ANSI/BIFMA X5.1-2017



BRANCH (p. 12)
side chair, armchair

ANSI/BIFMA X5.1-2011

EN1022:2005 6
EN581-1:2006 5
EN 1728:2012

ASTM B117-11 (Mod.)

CPSD-HL-01010-MTHD
CPSD-HL-01012-MTHD



CTR (p. 16)
armchair

ANSI/BIFMA X5.1-2011

EN1022:2005 6
EN581-1:2006 5
EN 1728:2012

ASTM B117-11 (Mod.)

CPSD-HL-01010-MTHD
CPSD-HL-01012-MTHD



ILLUM (p. 28)
armchair

ANSI/BIFMA X5.1-2011

EN1022:2005 6
EN581-1:2006 5
EN 1728:2012

ASTM B117-11 (Mod.)

CPSD-HL-01010-MTHD
CPSD-HL-01012-MTHD



KOS (p. 32)
armchair, lounge chair

ANSI/BIFMA X5.1-2011

EN1022:2005 6
EN581-1:2006 5
EN 1728:2012

CPSD-HL-01063-MTHD
CPSD-HL-01012-MTHD



MOOD (p. 36-37)
armchair, lounge chair, bar chair

ANSI/BIFMA X5.1-2011

EN1022:2005 6
EN581-1:2006 5
EN 1728:2012

ASTM B117-11 (Mod.)

CPSD-HL-01010-MTHD
CPSD-HL-01012-MTHD
CPSD-HL-01063-MTHD

AATCC 16
AATCC 106
AATCC 162



NODI (p. 49)
armchair, lounge chair

ANSI/BIFMA X5.1-2011

EN1022:2005 6
EN581-1:2006 5
EN 1728:2012

ASTM B117-11 (Mod.)

CPSD-HL-01010-MTHD
CPSD-HL-01012-MTHD



NOMAD (p. 58)
armchair, lounge chair

BIFMA X5.1-2017

EN581-1:2017
EN581-2:2015/AC2016

ANSI/BIFMA X5.1-2017



SENJA WITH ALU LEGS (p. 70)
armchair, lounge chair

BIFMA X5.4-2020



TOSCA (p. 89)
armchair

ANSI/BIFMA X5.1-2011

EN1022:2005 6
EN581-1:2006 5
EN 1728:2012

ASTM B117-11 (Mod.)

CPSD-HL-01010-MTHD
CPSD-HL-01012-MTHD

AATCC 16
AATCC 106
AATCC 162



TECHNICAL STANDARDS LOUNGERS

NORMES TECHNIQUES - TECHNISCHE NORMEN

BRANCH (p. 12)
lounger

ANSI/BIFMA X5.4 - 2012 ASTM B117-11 (Mod.)

CPSD-HL-01010-MTHD
CPSD-HL-01012-MTHD



FORUM (p. 27)
lounger

ANSI/BIFMA X5.4 - 2012

EN 581-1:2006 5.1
EN 581-1:2006 5.2
EN 581-1:2006 5.3.1
EN 581-1:2006 5.3.3
EN 581-1:2006 6.2.1

EN581-2:2009 Annex A
EN581-2:2009 B.2.1.3
EN581-2:2009 B.2.1.7
EN581-2:2009 B.3.1.1
EN581-2:2009 B.3.1.2

EN1728:2000 6.2.1
EN1728:2000 6.2.2
EN1728:2000 6.3
EN1728:2000 6.7
EN1728:2000 6.9
EN1728:2000 6.12
EN1728:2000 6.13
EN1728:2000 6.15

EN1022:2005 6.2
EN1022:2005 6.4
EN1022:2005 6.6
EN1022:2005 7.5



KOS (p. 33)
lounger

ANSI/BIFMA X5.4 - 2012

CPSD-HL-01063-MTHD
CPSD-HL-01012-MTHD



SENJA (p. 71)
lounger

ANSI/BIFMA X5.4 - 2012



TOSCA (p. 92)
lounger

ANSI/BIFMA X5.4 - 2012 ASTM B117-11 (Mod.)

CPSD-HL-01010-MTHD
CPSD-HL-01012-MTHD

AATCC 16
AATCC 106
AATCC 162



PRICING CUSHIONS

TARIFICATION DES COUSSINS - PRIJZENSISTEEM KUSSENS

CATEGORIES

The price of the cushions depends on the type of fabric.

All of our cushions are made to order and can therefore not be cancelled after 24 h. The delivery time is 4 weeks.

	CATEGORY D	CATEGORY E	CATEGORY F
FABRIC	Sunbrella®	Basc Duas Knit Linen Natural Nesso Rustic Weave Yuttu	Naram Siva Sujàn

CATÉGORIES

Le prix des coussins dépend du type de tissu.

Tous nos coussins sont fabriqués sur commande et ne peuvent plus être annulés après 24h. Le délai de livraison est de 4 semaines.

	CATÉGORIE D	CATÉGORIE E	CATÉGORIE F
TISSU	Sunbrella®	Basc Duas Knit Linen Natural Nesso Rustic Weave Yuttu	Naram Siva Sujàn

CATEGORIEËN

De prijzen van de kussens worden bepaald door het type stof.

Al onze kussens worden op bestelling gemaakt en kunnen hierdoor na 24u niet meer geannuleerd worden. Als levertermijn moet u 4 weken voorzien.

	CATEGORIE D	CATEGORIE E	CATEGORIE F
STOF	Sunbrella®	Basc Duas Knit Linen Natural Nesso Rustic Weave Yuttu	Naram Siva Sujàn

FIRE RETARDANT CUSHIONS

DES COUSSINS FEU RETARDANT - BRANDVERTRAGENDE KUSSENS

For projects, Tribù is able to offer fire retardant cushions (foam and fabric).

We are happy to work with you on your project and find the best solution.
Please do not hesitate to contact our contract department (teamcontract@tribu.com) for a tailored solution.

Pour les projets, Tribù est capable d'offrir des coussins (mousse et tissu) feu retardant.

Nous sommes heureux de travailler avec vous sur votre projet et de rechercher la meilleure solution.
Contactez notre Service Contractuel (teamcontract@tribu.com) pour une solution sur mesure.

Voor projecten kan Tribù brandvertragend kussens (schuim en stof) aanbieden.

Wij werken graag samen met u aan uw project en zoeken naar de beste oplossing.
Contacteer onze contractafdeling (teamcontract@tribu.com) voor een oplossing op maat.

CAT. D

SUNBRELLA®



01 - Natté White



03 - Oyster



NEW

04 - Natté Sandstone



NEW

05 - Natté Poivre



06 - Natté Dune

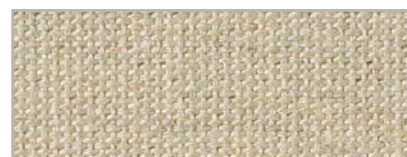

07 - Papyrus*

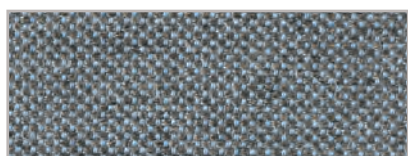

08 - Natté Carbon Sky

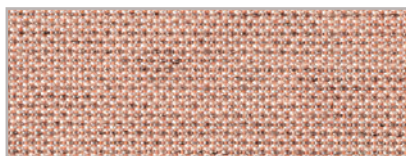

11 - Blush

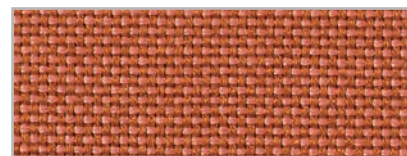

13 - Indian Summer

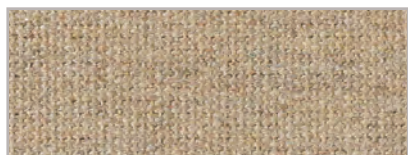

15 - Ashe*



NEW

29 - Moss

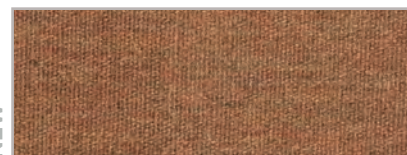

NEW

31 - Copper



NEW

32 - Mahogany

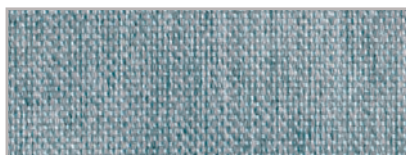

34 - Natté Frost Chiné



40 - Natté Olive

*This fabric is made with recycled fabric. Due to its specific character, it may show irregularities.

*Ce tissu est fabriqué avec des tissus recyclés. Des irrégularités peuvent se reproduire ce qui fait partie du caractère spécifique de ce tissu.

*Deze stof is gemaakt met gerecycleerde stoffen. Hierdoor kunnen onregelmatigheden voorkomen die deel uitmaken van het specifieke karakter van deze stof.

Smooth fabrics are less prone to looping.

Les tissus lisses ont moins tendance à produire des boucles.

Gladde stoffen zijn minder vatbaar voor lusvorming.

COLORS - COULEURS - KLEUREN

CAT. D

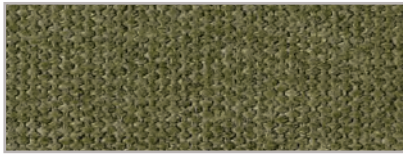

42 - Leaf*

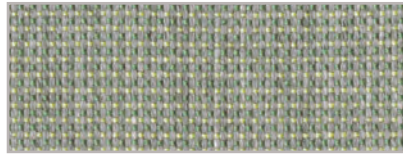

44 - Natté Anis



45 - Natté Mist



46 - Natté Stardust



47 - Natté Ochre



64 - Natté Nature grey



65 - Natté Basalt



69 - Natté Silvergrey



75 - Natté Charcoal



76 - Granite*



89 - Natté Wengé

The reproduction of colors may differ from reality.
La représentation des couleurs peut varier de la réalité.
De weergave van kleuren kan verschillen met de werkelijkheid.

BASC



E51 - Seasalt



E54 - Flax



E55 - Alabaster



E56 - Mellow Ochre

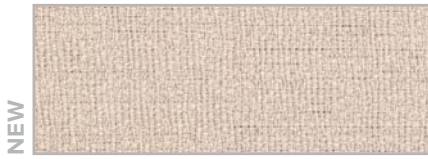

E57 - Papyrus

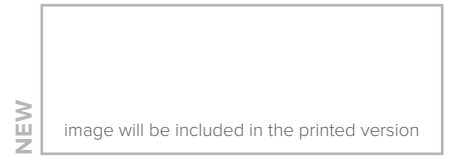

E91 - Artic

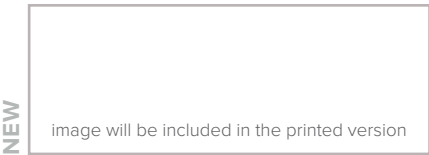

E93 - Mushroom

*This fabric is made with recycled fabric. Due to its specific character, it may show irregularities.

*Ce tissu est fabriqué avec des tissus recyclés. Des irrégularités peuvent se reproduire ce qui fait partie du caractère spécifique de ce tissu.

*Deze stof is gemaakt met gerecycleerde stoffen. Hierdoor kunnen onregelmatigheden voorkomen die deel uitmaken van het specifieke karakter van deze stof.

Smooth fabrics are less prone to looping.

Les tissus lisses ont moins tendance à produire des boucles.

Gladder stoffen zijn minder vatbaar voor lusvorming.

COLORS - COULEURS - KLEUREN

CAT. E

YUTTU



E61 - Seasalt



E64 - Flax



E65 - Alabaster

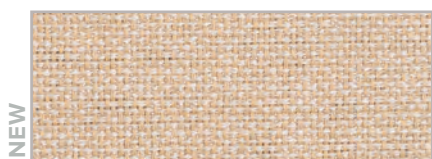

E66 - Mellow Ochre



E67 - Papyrus

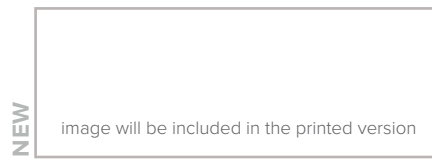

E95 - Artic

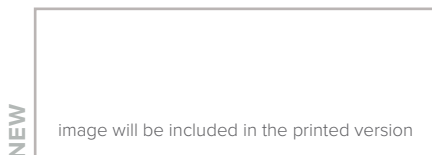

E97 - Mushroom

KNIT



E32 - Morning Dew



E34 - Silverstone



E35 - Dunes



E39 - Wengé



E43 - Rosemary



E44 - Licorice



E45 - Mellow Ochre

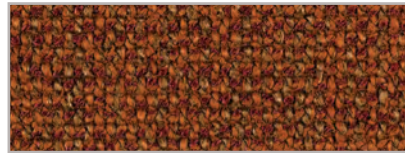

E48 - Dark Copper

Smooth fabrics are less prone to looping.
Les tissus lisses ont moins tendance à produire des boucles.
Gladdes stoffen zijn minder vatbaar voor lusvorming.

COLORS - COULEURS - KLEUREN

CAT. E

NESSO



NEW

E70 - Almond

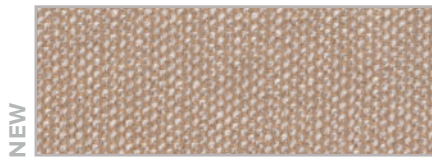

NEW

E71 - Ochre Mist



NEW

E72 - Carbon Sky



NEW

E73 - Sky Mist

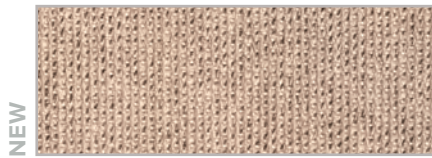

NEW

E74 - Ice Blue



NEW

E75 - Leaf

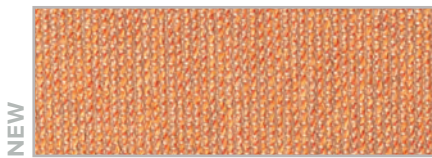

NEW

E76 - Sunset

CAT. E

LINEN

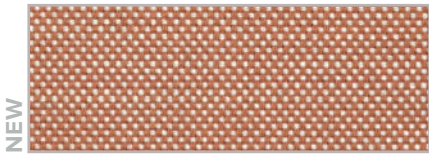

E79 - Venice



E80 - Sandstone



E81 - Linen**



E82 - White Sand



E83 - Washed Linen**



E84 - Chalk**



E85 - Granite

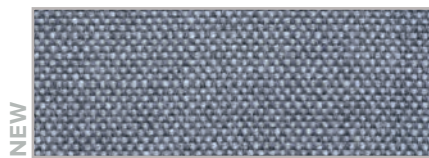

E86 - Oxford Blue

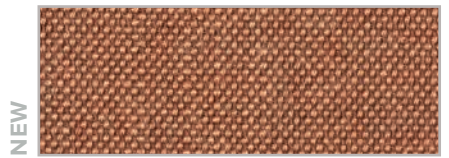

E100 - Burgundy



E101 - Sunset



E102 - Ruby

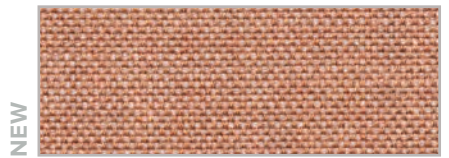

E103 - Mushroom



E104 - Dusty Rose



E105 - White Quartz

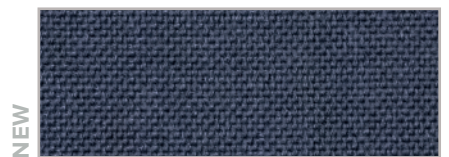

E107 - Dark Blue



E108 - Frost Blue



E109 - Moss



E111 - Verdant Grey

** For repeat or replacement orders please use the 2024 code numbers, as they differ from the 2025 versions.

Smooth fabrics are less prone to looping.
 Les tissus lisses ont moins tendance à produire des boucles.
 Gladde stoffen zijn minder vatbaar voor lusvorming.

CAT. E

RUSTIC WEAVE



B140 - Rustic Weave Dark Grey



B143 - Rustic Weave Oyster



B144 - Rustic Weave Cord



B146 - Rustic Weave Ice Grey



B147 - Rustic Weave Black

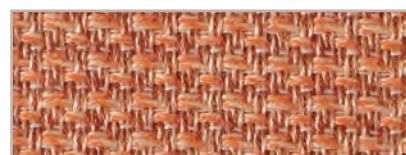

B150 - Rustic Weave Abricot



B151 - Rustic Weave Brown

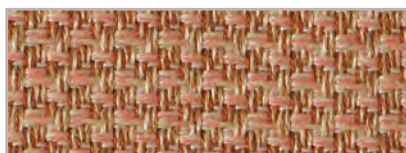

B152 - Rustic Weave Fresco

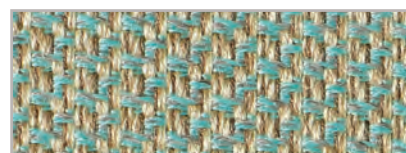

B153 - Rustic Weave Lagoon

NATURAL



B154 - Natural Seashell



B155 - Natural Cloudy Sky



B156 - Natural Aged Ivory

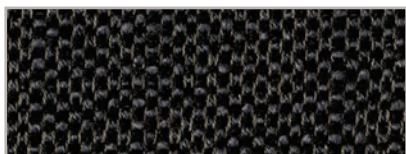

B157 - Natural Umbra



B193 - Natural Off-White

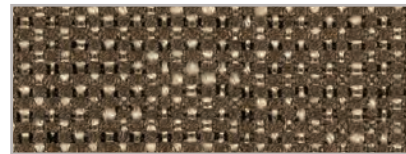

B194 - Natural Dark Brown

The reproduction of colors may differ from reality.
La représentation des couleurs peut varier de la réalité.
De weergave van kleuren kan verschillen met de werkelijkheid.

CAT. E

DUAS



E120 - Cotton White



E121 - Cream White



E122 - Almond



E123 - Linen



E124 - Carbon Sky



E125 - Wengé



E130 - Ivory

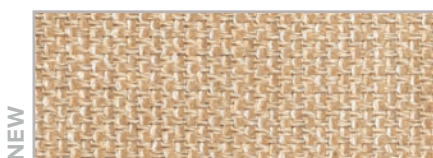

E131 - Dunes



E132 - Rustic Brown

Smooth fabrics are less prone to looping.
Les tissus lisses ont moins tendance à produire des boucles.
Gladde stoffen zijn minder vatbaar voor lusvorming.

COLORS - COULEURS - KLEUREN

CAT. F

SUJÀN



F01 - Hemp

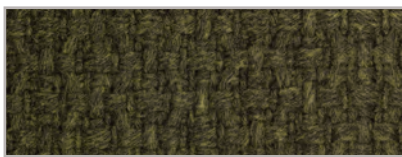

F02 - Moss



F04 - Ochre



NEW

F17 - Nature Grey

SIVA



NEW

F50 - Cotton White

NARAM



F19 - Pearl



F20 - Almond



F21 - Warm Cotton



F80 - Oyster



F81 - Herb



F82 - Rosemary



F84 - Denim



F85 - Frost

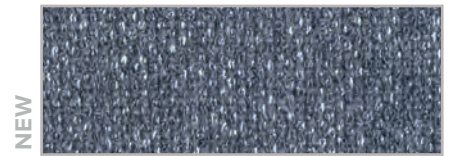

F86 - Indigo



F87 - Moss



F88 - Verdant



F89 - Ochre

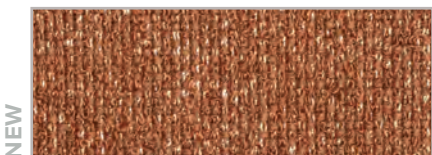

F90 - Copper

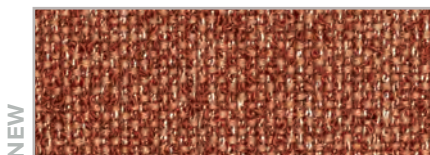

F91 - Merlot

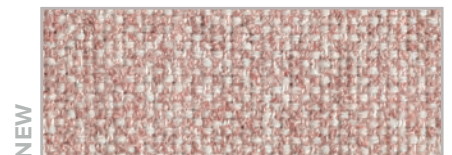

F92 - Cerise

Smooth fabrics are less prone to looping.
Les tissus lisses ont moins tendance à produire des boucles.
Gladdes stoffen zijn minder vatbaar voor lusvorming.

COLORS - COULEURS - KLEUREN

PAVILION & PURE CABANA

SUNSCAPE



S54 - Sunscape Oyster

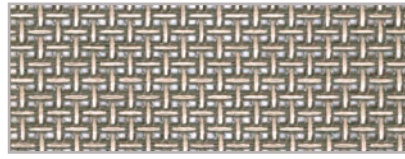

S64 - Sunscape Nature Grey

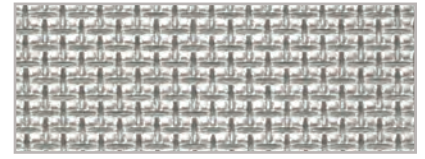

S70 - Sunscape Stone

VELUM



V54 - Velum Oyster



V64 - Velum Nature Grey



V70 - Velum Stone

The reproduction of colors may differ from reality.
La représentation des couleurs peut varier de la réalité.
De weergave van kleuren kan verschillen met de werkelijkheid.

FILLINGS

REMBOURRAGES - VULLINGEN

OUTDOOR FILLING

All our cushions are weatherproof, which means you can leave them outside, even during short periods of rain. To preserve the beautiful appearance of the cushions, it is best to keep them indoors during autumn and winter. Depending on the design of the cushions, there are 2 different systems:

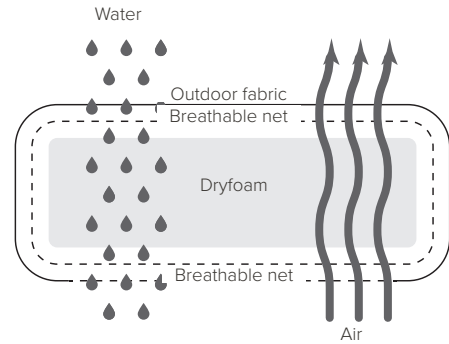
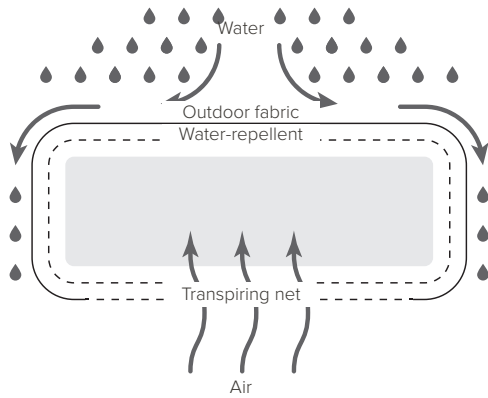

water-repellent fillings have a cover in a laminated, water-repellent polypropylene material which prevents water from penetrating. The thread used to stitch the seams swells when getting wet, preventing water from penetrating through the seams. On top of that, the seams are protected on the inside with an extra covering. If nevertheless water should penetrate, the material is breathable, letting moisture out to prevent moulding.

(AMANU, CTR BACK CUSHIONS, ELIO, MOOD SOFA, NATAL ALU SOFA, NODI SOFA, NOMAD, PURE, SENJA, SURO, TOSCA & VIS À VIS SOFA)

water-permeable fillings (dryfoam) have an open cell structure so air can circulate freely. Water passes through the filling but dries quickly thanks to the large open pores, substantially inhibiting fungal growth.

(CTR SEAT CUSHIONS, NODI, PAVILION DAYBED, KOS & UKIYO)

INCOMPARABLE COMFORT

In addition to the water-repellent properties mentioned above, the cushions of our Nodi sofa, Pure sofa and Elio sofa are filled with an innovative, new generation material with a remarkable softness, outstanding shape-retention and excellent breathability.

This new, natural and recyclable polyester fibre is set to change the world of synthetic foams and fibres used for cushion fillings. As a result of its unique molecular structure, it maintains its bounce even after repeated compressions and

quickly recovers its airy volume. Thanks to its high durability, its unique texture is retained for a long time.

The back cushions consist of compartments fully filled with this new fibre, combined with recycled memory-foam particles. This provides excellent support and form stability.

The seat cushions are filled with high quality PU foam with a padding in non-carded microfibre that has been developed for its softness, fluffiness and comfort, creating a seat cushion with the same performance as feathers and down.

(NODI SOFA, PURE SOFA & ELIO SOFA)



Outstanding softness

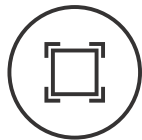

Excellent shape retention

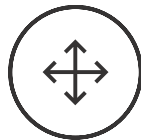

Comfortable stretch



Highly ecological



Superior rebound

REMBOURRAGE POUR L'EXTÉRIEUR

Tous nos coussins sont résistants aux intempéries. Ils peuvent donc rester dehors, même pendant de courtes périodes de pluie. Afin de conserver au mieux la beauté de vos coussins, nous vous recommandons de les rentrer à l'intérieur en automne et en hiver. Dépendant du design des coussins, il existe deux types de rembourrages différents :

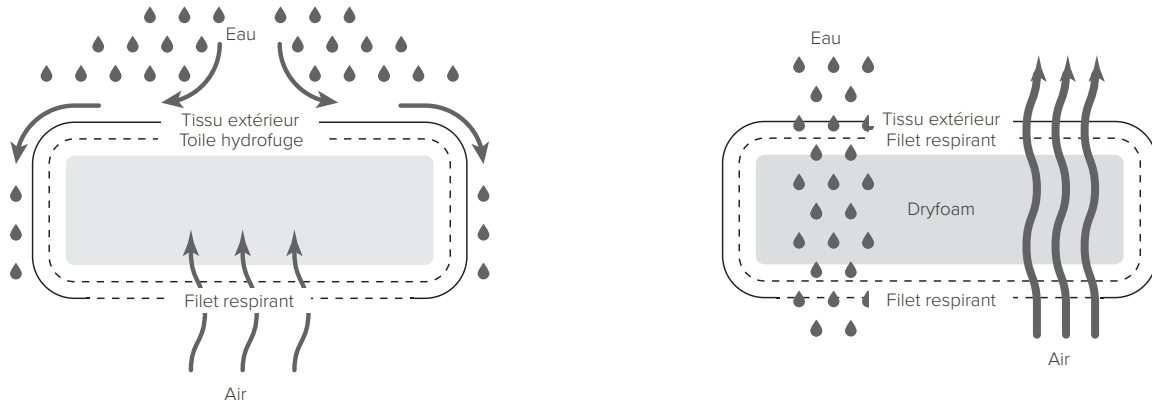

les rembourrages imperméables à l'eau disposent d'une toile en polypropylène laminé hydrofuge, ce qui empêche l'eau d'y pénétrer. Le fil utilisé pour coudre les coutures, gonfle quand il est mouillé, empêchant l'eau de pénétrer à travers les coutures. En plus, les coutures sont protégées à l'intérieur avec une couverture supplémentaire. Si néanmoins de l'eau rentre, le matériau est respirant : il permet à l'humidité de s'évacuer afin d'éviter le risque de moisissure.

(AMANU, CTR COUSSINS DOSSIER, ELIO, MOOD SOFA, NATAL ALU SOFA, NODI SOFA, NOMAD, PURE, SENJA, SURO, TOSCA & VIS À VIS SOFA)

les rembourrages perméables à l'eau (dryfoam) disposent d'une structure à cellules ouvertes ce qui permet à l'air de circuler librement. L'eau passe à travers le rembourrage, mais sèche très rapidement grâce aux larges pores, ce qui limite le risque de moisissure.

(CTR COUSSINS D'ASSISE, NODI, PAVILION DAYBED, KOS & UKIYO)

UN CONFORT INCOMPARABLE.

En plus des propriétés hydrofuges mentionnées ci-dessus, les coussins de notre canapé Nodi sofa, Pure sofa et Elio sofa sont rembourrés d'un matériau innovant de dernière génération qui offre une douceur remarquable, une excellente mémoire de forme et une respirabilité hors du commun.

Ce nouveau fibre de polyester naturel recyclable va révolutionner le monde de la fibre et de la mousse synthétiques utilisées jusqu'à présent pour le rembourrage des coussins. Grâce à sa structure moléculaire unique, elle retrouve rapidement sa forme et son volume aéré, même après des compressions répétées. Grâce à sa haute résistance, elle

conservera longtemps sa texture unique.

Les coussins de dossier du canapé sont constitués de compartiments entièrement remplis de cette nouvelle fibre, combinée à des particules de mousse à mémoire de forme recyclée. La garantie d'un soutien et d'une stabilité de forme remarquables.

Les coussins de siège sont remplis de mousse PU de haute qualité avec une couche supérieure en microfibre non cardée avec une douceur et un confort comparables à ceux des plumes et du duvet.

(NODI SOFA, PURE SOFA & ELIO SOFA)



Douceur
exceptionnelle

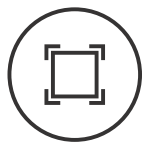

Maintient sa forme



Élasticité confortable



Hautement
écologique

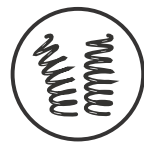

Excellente
mémoire de forme

BUITENVULLING

Al onze kussens zijn weerbestendig waardoor u ze gewoon buiten kan laten liggen, ook tijdens korte periodes van regen. Om uw kussens langer mooi te houden, haalt u ze tijdens de herfst- en winterperiode best binnen. Afhankelijk van het design van de kussens, gebruiken we 2 verschillende systemen:

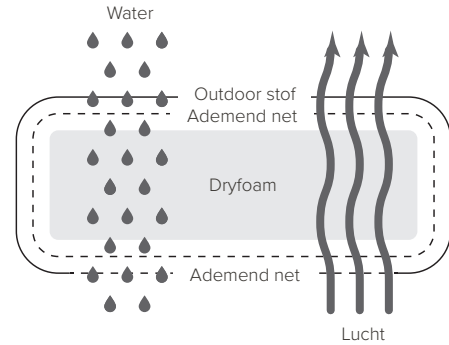
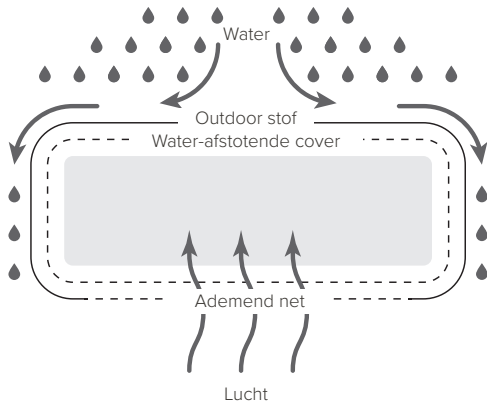

Waterafstotende kussens hebben een hoes rond de vulling in gelamineerd, waterafstotend polypropyleen waardoor water niet in de vulling kan binnendringen. De draad die gebruikt wordt om de naden te stikken, zwelt op als hij vochtig wordt, waardoor water ook niet langs de naden kan binnenkomen. Bovendien worden de naden aan de binnenzijde ook nog beschermd met een extra hoesje. Indien water toch nog zou binnensijpelen, kan het vocht eruit omdat de vulling ventilerend is.

(AMANU, CTR RUGKUSSENS, ELIO, MOOD SOFA, NATAL ALU SOFA, NODI SOFA, NOMAD, PURE, SENJA, SURO, TOSCA & VIS À VIS SOFA)

Waterdoorlaatbare kussens (dryfoam) hebben een open celstructuur waardoor lucht vrij kan circuleren. Water penetreert door de vulling maar droogt snel dankzij de grote, open poriën waardoor schimmel weinig kans krijgt.

(CTR ZITKUSSENS, NODI, PAVILION DAYBED, KOS & UKIYO)

EEN ONVERGELIJKBAAR COMFORT.

Bovenop de waterafstotende eigenschappen zoals hierboven vermeld, zijn de kussens van onze Nodi sofa, Pure sofa en Elio sofa gevuld met een innovatief materiaal van de nieuwste generatie met een opmerkelijke zachtheid, perfecte vormvastheid en een uitstekend ademend vermogen. Deze nieuwe, natuurlijke, recycleerbare polyestervezels zullen de wereld van synthetische vezels en schuimvullingen voorgoed veranderen. Dankzij hun unieke moleculaire structuur nemen ze snel terug hun vorm en luchtig volume aan, zelfs na herhaaldelijk samendrukken. Dankzij de hoge duurzaamheid

behouden ze hun unieke textuur voor lange tijd. De rugkussens van de sofa bestaan uit compartimenten die volledig gevuld zijn met deze nieuwe vezels gecombineerd met gerecycleerde memory foam deeltjes. Dit zorgt voor een uitstekende ondersteuning en vormstabiliteit. De zitkussens zijn gevuld met hoogwaardig PU-schuim met een toplaag in niet-gekaarde microvezel met een zachtheid en comfort vergelijkbaar met veren en dons.

(NODI SOFA, PURE SOFA & ELIO SOFA)



Voortreffelijke zachtheid



Excellente vormvastheid



Comfortabele stretch



Zeer milieuvriendelijk



Superieure terugvering

FABRIC TYPES

TYPES DE TISSUS - STOF TYPES

INFORMATION

Tribù offers a selection of 124 different outdoor fabrics, all carefully chosen to match our discreet luxury character. Each fabric is engineered with high performance characteristics that provide resistance to fading from sunlight and offer a long life. Durable, yet very tactile. Within our range, we work with 3 different fabric types, see overview beneath. You can find more info on these fabric types on the following pages.

INFORMATION

Tribù propose une gamme de 124 tissus pour l'extérieur, tous soigneusement choisis afin de correspondre à notre image de luxe discret. Chaque tissu est conçu avec des caractéristiques de haute performance qui offrent une résistance à la décoloration due à la lumière du soleil et une longue durée de vie. Durable, mais aussi très agréable au toucher. Au sein de notre gamme, nous travaillons avec 3 types de tissus différents, voir le tableau ci-dessous. Vous pouvez trouver plus d'informations sur ces types de tissu dans les pages suivantes.

INFORMATIE

Tribù beschikt over een gamma van 124 verschillende buitenstoffen, allemaal zorgvuldig gekozen om te matchen bij ons discrete luxe karakter. Elke stof is geproduceerd met high-performance kenmerken die weerstaan aan de invloed van de zon en een lange levensduur garanderen. Duurzaam, maar toch zeer tactiel. In ons gamma werken we met 3 verschillend types stof, zie tabel hier beneden. U vindt meer info over deze types stof op de volgende bladzijden.

	SOLUTION DYED ACRYLIC	SOLUTION DYED POLYOLEFIN	PVC COATED POLYESTER
Basc	x		
Duas	x		
Knit		x	
Linen	x		
Naram	x		
Natural	x		
Nesso	x		
Rustic Weave	x		
Siva	x		
Sujàn	x		
Sunbrella®	x		
Sunscape	x		x
Velum	x		
Yuttu	x		

Smooth fabrics are less prone to looping.
Les tissus lisses ont moins tendance à produire des boucles.
Gladde stoffen zijn minder vatbaar voor lusvorming.

SOLUTION DYED ACRYLICS

DES TEXTILES EN ACRYLIQUE TEINTÉS DANS LA MASSE - IN DE MASSA GEVERFD ACRYL

BASC, DUAS, LINEN, NARAM, NATURAL, NESSO, RUSTIC WEAVE, SIVA, SUJÀN, SUNBRELLA® & YUTTU



INFORMATION

Acrylic fabrics are durable, high-performance synthetic fabrics made from acrylic fibers. They have a number of advantages including mildew-resistant properties and a minimal absorbency of liquids. The acrylics Tribù uses are solution-dyed which means that they are dyed before the yarn is created. A liquid acrylic solution is mixed with the dye and is then formed into a fiber so it already has color before it is spun into a yarn. This process guarantees an optimal colour fastness. Their ability to breathe prevents mold from building up on the surfaces of the fabric. The open weave provides air flow helping to reduce heat and humidity. In addition to the technical performance, acrylic fabrics have a very soft look and feel, creating the perfect ambiance for your outdoor furniture. Our solution dyed fabrics are treated with a special Teflon® coating to make them water repellent and resistant to stains, grease, fluids and salt or chlorine water.

MAINTENANCE

The covers of all our cushions can be removed and cleaned. All solution dyed acrylics can be washed at 30° C. After washing we recommend to apply Textile Protector (p. 209) which provides the fabric with an invisible, water- and stain repellent film.

INFORMATION

Les tissus en acrylique sont des textiles synthétiques résistants, de très grande qualité, fabriqués à partir de fibres en acrylique. Ils ont de très nombreux avantages, parmi lesquels des propriétés antifongiques et un degré d'absorption des liquides très faible. Les tissus en acrylique utilisés par Tribù sont teintés dans la masse ce qui signifie qu'ils sont teintés avant même la création du fil de tissage. On mélange une solution liquide acrylique avec le colorant qui est ensuite transformé en fibre. Celle-ci est donc déjà teintée avant d'être filée. Ce processus garantit une tenue optimale des couleurs. Leurs propriétés respirantes ne laissent aucune chance aux moisissures. Par ailleurs, le tissage aéré permet une meilleure circulation de l'air, de sorte que les tissus ne deviennent jamais ni chauds, ni humides. Outre leurs caractéristiques techniques exceptionnelles, les textiles en acrylique présentent un aspect très doux visuellement, mais également au toucher, ce qui permet de recréer en extérieur une atmosphère confortable et agréable. Tous nos tissus subissent un traitement au Teflon®, ce qui les rend hydrofuges, antitaches et résistants à l'eau saline et chlorée.

ENTRETIEN

Toutes les housses de nos coussins peuvent être retirées afin d'être nettoyées. Tous les tissus en acrylique peuvent être lavés à 30 °C. Après lavage, il est recommandé de vaporiser dessus Textile Protector (p. 209), qui va le protéger d'un film invisible hydrofuge et antitache.

INFORMATIE

Acryl stoffen zijn duurzame, hoogwaardige synthetische stoffen gemaakt van acrylvezels. Ze hebben een aantal voordelen, zoals een weerstand tegen schimmel en een minimale absorptie van vloeistoffen. De acryl die Tribù gebruikt, is in de massa geverfd wat betekent dat de vezels zijn geverfd voordat het garen wordt gemaakt. Een vloeibare acryloplossing wordt gemengd met de kleurstof en vervolgens tot een vezel gevormd, zodat het al kleur heeft voordat het tot garen gesponnen wordt. Dit proces garandeert een optimale kleurvastheid. Hun ademende eigenschappen geven schimmel weinig kans. De open weving zorgt eveneens voor luchtcirculatie waardoor de stoffen niet heet of plakkerig worden. Naast hun bijzondere technische eigenschappen, hebben acryl stoffen ook een zeer zachte look & feel, waardoor ze de perfecte sfeer op uw terras kunnen creëren. Al onze stoffen hebben een Teflon® behandeling gekregen waardoor ze water, vlek- en vetafstotend zijn en bestand tegen zout en chloorwater.

ONDERHOUD

Alle hoezen van onze kussens kunnen verwijderd worden en gereinigd. Alle acryl stoffen kunnen gewassen worden op 30° C. Na het wassen is het raadzaam om de stof in te spuiten met Textile Protector (p. 209) die een onzichtbare, water- en vlekafstotende film aanbrengt.

SOLUTION DYED POLYOLEFIN

DES TEXTILES EN POLYOLÉFINE TEINTÉS DANS LA MASSE - IN DE MASSA GEVERFD POLYOLEFIN

KNIT



INFORMATION

Solution dyed polyolefin fabrics are the perfect combination of ecology (100% recyclable), durability and performance, being twice as strong as acrylics. Polyolefin fabrics are resistant to water, mildew and stains. Combined with their high abrasion and pilling resistance, it makes them the perfect fabrics for your outdoor furniture. Their UV-resistance is dependent on the colour and might be lower than solution dyed acrylic fabrics (test results can be found on the back of your sample swatch and on p. 160). In case of lower results, slight fading of the colour might occur after 2 years.

MAINTENANCE

The cover of all our cushions can be removed and cleaned. All solution-dyed polyolefin fabrics can be washed at 30° C. After washing we recommend to apply Textile Protector (p. 209) which provides the fabric with an invisible, water- and stain repellent film.

INFORMATION

Les tissus en polyoléfine teintés dans la masse constituent l'alliance parfaite entre écologie (100 % recyclables), caractère inusable et haute qualité, étant deux fois plus résistants que les tissus en acrylique. Ils sont imperméables, hydrofuges et antitaches. Le fait qu'ils soient également anti-abrasifs et anti-peluches, en font des tissus parfaits pour habiller vos meubles d'extérieur. Leur résistance aux UV est variable selon la couleur et peut être moins efficace que pour des tissus en acrylique teintés dans la masse (vous pourrez consulter les résultats des tests au dos de chaque coupon de tissu ou p. 160). En cas de moins bons résultats, on observe en général un début de décoloration au bout de 2 ans.

ENTRETIEN

Toutes les housses de nos coussins peuvent être retirées et nettoyées. Tous les tissus en polyoléfine peuvent être lavés à 30 °C. Après lavage, il est recommandé de vaporiser dessus Textile Protector (p. 209), qui va le protéger d'un film invisible hydrofuge et antitache.

INFORMATIE

In de massa geleverde polyolefin stoffen, zijn de perfecte combinatie van milieuvriendelijkheid (100% recycleerbaar), duurzaamheid en prestatie. Ze zijn dubbel zo sterk als acrylstoffen. Polyolefin stoffen zijn water-, schimmel- en vlekbestendig. In combinatie met hun hoge weerstand tegen wrijving en pluizen, zijn dit de perfecte stoffen voor uw buitenmeubelen. Hun UV-weerstand is afhankelijk van de kleur en zou lager kunnen zijn dan in de massa geleverd acryl (testresultaten vindt u aan de achterkant van uw stofstalenbundel of op p. 160). In het geval van lagere resultaten, kan lichte vervaging van de kleur optreden na 2 jaar.

ONDERHOUD

Alle hoezen van onze kussens kunnen verwijderd worden en gereinigd. Alle polyolefin stoffen kunnen gewassen worden op 30° C. Na het wassen is het raadzaam om de stof in te spuiten met Textile Protector (p. 209) die een onzichtbare, water- en vlekafstotende film aanbrengt.

PVC COATED POLYESTER

POLYESTER ENDUIT DE PVC - PVC GECOAT POLYESTER

SUNSCAPE



INFORMATION

These fabrics are composed of polyester that is coated with PVC. The polyester provides strength and dimensional stability, while the PVC coating makes the material waterproof and resistant to dirt, mildew, oil, salt, chemicals and UV rays. It also gives the material added strength and durability.

MAINTENANCE

PVC coated fabrics are very maintenance friendly and can easily be cleaned with clear water, a pH- neutral soap and a soft brush. Rinse with clear water. Stubborn stains can be removed with Synthetics Super Cleaner (p. 208).

INFORMATION

Ces tissus sont composés de polyester, recouvert de PVC. Le polyester assure solidité et stabilité dimensionnelle, tandis que l'enduit de PVC rend le matériau imperméable et résistant à la saleté, la moisissure, huile, sel, produits chimiques et aux rayons UV. En plus, il augmente encore la solidité et durabilité.

ENTRETIEN

Le polyester enduit de PVC est très facile à entretenir et se nettoie aisément avec de l'eau pure, un savon à pH neutre et une brosse douce. Rincez ensuite à l'eau propre. Les taches récalcitrantes peuvent être éliminées avec le Synthetics Super Cleaner (p. 208).

INFORMATIE

Deze stoffen zijn samengesteld uit polyester dat gecoat wordt met PVC. De polyester biedt sterkte en dimensionale stabiliteit, terwijl de PVC-coating het materiaal waterdicht maakt en bestand tegen vuil, schimmel, olie, zout, chemicaliën en UV-stralen. Het voegt ook extra sterkte en duurzaamheid toe.

ONDERHOUD

Deze stoffen zijn zeer onderhoudsvriendelijk en kunnen gemakkelijk gereinigd worden met zuiver water, een pH-neutrale zeep en een zachte borstel. Naspoelen met zuiver water. Hardnekkige vlekken kunnen verwijderd worden met de Synthetics Super Cleaner (p. 208).

FABRIC PROPERTIES

PROPRIÉTÉS DES TISSUS - STOFFEIGENSCHAPPEN

	Code	Category	Composition	Weight (g/m ²)
SUNBRELLA®				
Natté White	01	Cat. D	Sunbrella® Solution dyed acrylic	290
Oyster	03	Cat. D	Sunbrella® Solution dyed acrylic	280
Natté Sandstone NEW	04	Cat. D	Sunbrella® Solution dyed acrylic	290
Natté Poivre NEW	05	Cat. D	Sunbrella® Solution dyed acrylic	290
Natté Dune	06	Cat. D	Sunbrella® Solution dyed acrylic	290
Papyrus*	07	Cat. D	Sunbrella® 50% recycled acrylic - 47% acrylic - 3% PE	340
Natté Carbon Sky	08	Cat. D	Sunbrella® Solution dyed acrylic	290
Blush	11	Cat. D	Sunbrella® Solution dyed acrylic	260
Indian Summer	13	Cat. D	Solution dyed acrylic	275
Ashe*	15	Cat. D	Sunbrella® 50% recycled acrylic - 47% acrylic - 3% PE	340
Moss	29	Cat. D	Sunbrella® 50% recycled acrylic - 47% acrylic - 3% PE	365
Copper	31	Cat. D	Sunbrella® 50% recycled acrylic - 47% acrylic - 3% PE	335
Mahogany	32	Cat. D	Sunbrella® 50% recycled acrylic - 47% acrylic - 3% PE	335
Natté Frost Chiné	34	Cat. D	Sunbrella® Solution dyed acrylic	290
Natté Olive	40	Cat. D	Sunbrella® Solution dyed acrylic	290
Leaf*	42	Cat. D	Sunbrella® 50% recycled acrylic - 47% acrylic - 3% PE	340
Natté Anis	44	Cat. D	Sunbrella® Solution dyed acrylic	290
Natté Mist	45	Cat. D	Sunbrella® Solution dyed acrylic	290
Natté Stardust	46	Cat. D	Sunbrella® Solution dyed acrylic	290
Natté Ochre	47	Cat. D	Sunbrella® solution dyed acrylic	290
Natté Nature Grey	64	Cat. D	Sunbrella® Solution dyed acrylic	290
Natté Basalt	65	Cat. D	Sunbrella® Solution dyed acrylic	290
Natté Silvergrey	69	Cat. D	Sunbrella® Solution dyed acrylic	290
Natté Charcoal	75	Cat. D	Sunbrella® Solution dyed acrylic	290
Granite*	76	Cat. D	Sunbrella® 50% recycled acrylic - 47% acrylic - 3% PE	340
Natté Wengé	89	Cat. D	Sunbrella® Solution dyed acrylic	290

BASC & YUTTU				
Seasalt NEW	E51 E61	Cat. D	Solution dyed acrylic	501
Flax NEW	E54 E64	Cat. D	Solution dyed acrylic	501
Alabaster NEW	E55 E65	Cat. D	Solution dyed acrylic	501
Mellow Ochre NEW	E56 E66	Cat. D	Solution dyed acrylic	501
Papyrus NEW	E57 E67	Cat. D	Solution dyed acrylic	501
Artic NEW	E91 E95	Cat. D	Solution dyed acrylic	501
Mushroom NEW	E93 E97	Cat. D	Solution dyed acrylic	501

DUAS				
Cotton White NEW	E120	Cat. D	Solution dyed acrylic	640
Cream White NEW	E121	Cat. D	Solution dyed acrylic	640
Almond NEW	E122	Cat. D	Solution dyed acrylic	640
Linen NEW	E123	Cat. D	Solution dyed acrylic	640
Carbon Sky NEW	E124	Cat. D	Solution dyed acrylic	640
Wengé NEW	E125	Cat. D	Solution dyed acrylic	640
Ivory NEW	E130	Cat. D	Solution dyed acrylic	480
Dunes NEW	E131	Cat. D	Solution dyed acrylic	480
Rustic Brown NEW	E132	Cat. D	Solution dyed acrylic	480

*This fabric is made with recycled fabric. Due to its specific character, it may show irregularities.

*Ce tissu est fabriqué avec des tissus recyclés. Des irrégularités peuvent se reproduire ce qui fait partie du caractère spécifique de ce tissu.

*Deze stof is gemaakt met gerecycleerde stoffen. Hierdoor kunnen onregelmatigheden voorkomen die deel uitmaken van het specifieke karakter van deze stof.

	Code	Abrasion Resistance Martindale	Colour fastness to UV scale of 1-5	Pilling scale of 1-5
SUNBRELLA®				
Natté White	01	25.000	3-4	5
Oyster	03	20.000	5	4-5
Natté Sandstone NEW	04	>40.000	3-4	4-5
Natté Poivre NEW	05	>40.000	3-4	4-5
Natté Dune	06	25.000	3-4	5
Papyrus*	07	25.000	3-4	5
Natté Carbon Sky	08	25.000	4	5
Blush	11	25.000	4	5
Indian Summer	13	12.000	4	3
Ashe*	15	25.000	4-5	5
Moss	29	>40.000	4	4-5
Copper	31	>40.000	4-5	4-5
Mahogany	32	>40.000	4-5	4-5
Natté Frost Chiné	34	25.000	4-5	5
Natté Olive	40	25.000	4	5
Leaf*	42	25.000	4-5	5
Natté Anis	44	25.000	4-5	5
Natté Mist	45	25.000	4-5	5
Natté Stardust	46	25.000	4	5
Natté Ochre	47	25.000	4-5	5
Natté Nature Grey	64	25.000	4-5	5
Natté Basalt	65	25.000	4-5	5
Natté Silvergrey	69	25.000	3-4	5
Natté Charcoal	75	25.000	4-5	5
Granite*	76	25.000	4-5	5
Natté Wengé	89	25.000	4-5	5

BASC & YUTTU				
Seasalt NEW	E51 E61	20.000	4	4
Flax NEW	E54 E64	20.000	4	4
Alabaster NEW	E55 E65	20.000	4	4
Mellow Ochre NEW	E56 E66	20.000	4	4
Papyrus NEW	E57 E67	20.000	4	4
Artic NEW	E91 E95	20.000	4	4
Mushroom NEW	E93 E97	20.000	4	4

DUAS				
Cotton White NEW	E120	30.000	3-4	4
Cream White NEW	E121	30.000	3-4	4
Almond NEW	E122	30.000	3-4	4
Linen NEW	E123	30.000	3-4	4
Carbon Sky NEW	E124	30.000	3-4	4
Wengé NEW	E125	30.000	3-4	4
Ivory NEW	E130	20.000	3-4	4
Dunes NEW	E131	20.000	3-4	4
Rustic Brown NEW	E132	20.000	3-4	4

FABRIC PROPERTIES

PROPRIÉTÉS DES TISSUS - STOFFEIGENSCHAPPEN

	Code	Category	Composition	Weight (g/m ²)
KNIT				
Morning Dew	E32	Cat. E	100% solution dyed polyolefin	710
Silverstone	E34	Cat. E	100% solution dyed polyolefin	710
Dunes NEW	E35	Cat. E	100% solution dyed polyolefin	995
Wengé	E39	Cat. E	100% solution dyed polyolefin	710
Rosemary	E43	Cat. E	100% solution dyed polyolefin	710
Licorice	E44	Cat. E	100% solution dyed polyolefin	710
Mellow Ochre	E45	Cat. E	100% solution dyed polyolefin	710
Dark Copper	E48	Cat. E	100% solution dyed polyolefin	710

LINEN				
Venice NEW	E79	Cat. E	Solution dyed acrylic	592
Sandstone NEW	E80	Cat. E	Solution dyed acrylic	530
Linen NEW	E81	Cat. E	Solution dyed acrylic	530
White sand NEW	E82	Cat. E	Solution dyed acrylic	530
Washed linen NEW	E83	Cat. E	Solution dyed acrylic	530
Chalk NEW	E84	Cat. E	Solution dyed acrylic	530
Granite NEW	E85	Cat. E	Solution dyed acrylic	540
Oxford Blue NEW	E86	Cat. E	Solution dyed acrylic	592
Burgundy NEW	E100	Cat. E	Solution dyed acrylic	592
Sunset NEW	E101	Cat. E	Solution dyed acrylic	592
Ruby NEW	E102	Cat. E	Solution dyed acrylic	592
Mushroom NEW	E103	Cat. E	Solution dyed acrylic	592
Dusty Rose NEW	E104	Cat. E	Solution dyed acrylic	592
White Quartz NEW	E105	Cat. E	Solution dyed acrylic	530
Dark Blue NEW	E107	Cat. E	Solution dyed acrylic	592
Frost Blue NEW	E108	Cat. E	Solution dyed acrylic	540
Moss NEW	E109	Cat. E	Solution dyed acrylic	592
Verdant Grey NEW	E111	Cat. E	Solution dyed acrylic	592

NATURAL				
Seashell	B154	Cat. E	Solution dyed acrylic	365
Cloudy Sky	B155	Cat. E	Solution dyed acrylic	365
Aged Ivory	B156	Cat. E	Solution dyed acrylic	365
Umbra	B157	Cat. E	Solution dyed acrylic	365
Off-White	B193	Cat. E	Solution dyed acrylic	365
Dark Brown	B194	Cat. E	Solution dyed acrylic	365

NESSO				
Almond NEW	E70	Cat. E	Solution dyed acrylic	450
Ochre Mist NEW	E71	Cat. E	Solution dyed acrylic	450
Carbon Sky NEW	E72	Cat. E	Solution dyed acrylic	450
Sky Mist NEW	E73	Cat. E	Solution dyed acrylic	450
Ice Blue NEW	E74	Cat. E	Solution dyed acrylic	450
Leaf NEW	E75	Cat. E	Solution dyed acrylic	450
Sunset NEW	E76	Cat. E	Solution dyed acrylic	450

Code	Abrasion Resistance Martindale	Colour fastness to UV scale of 1-5	Pilling scale of 1-5
------	-----------------------------------	---------------------------------------	-------------------------

KNIT				
Morning Dew	E32	40.000	3-4	4.5
Silverstone	E34	40.000	3-4	4.5
Dunes NEW	E35	40.000	3	4-5
Wengé	E39	40.000	3-4	4.5
Rosemary	E43	40.000	3-4	4.5
Licorice	E44	40.000	3	4.5
Mellow Ochre	E45	40.000	3	4.5
Dark Copper	E48	40.000	2	4.5

LINEN				
Venice NEW	E79	15.000	4	4
Sandstone NEW	E80	15.000	4	4
Linen NEW	E81	20.000	3	4
White sand NEW	E82	20.000	3	4
Washed linen NEW	E83	20.000	3	4
Chalk NEW	E84	20.000	3	4
Granite NEW	E85	20.000	3	4
Oxford Blue NEW	E86	20.000	3	4
Burgundy NEW	E100	40.000	3	4-5
Sunset NEW	E101	40.000	3	4-5
Ruby NEW	E102	40.000	3	4-5
Mushroom NEW	E103	40.000	3	4-5
Dusty Rose NEW	E104	40.000	3	4-5
White Quartz NEW	E105	40.000	3	4-5
Dark Blue NEW	E107	40.000	3	4-5
Frost Blue NEW	E108	40.000	3	4-5
Moss NEW	E109	40.000	3	4-5
Verdant Grey NEW	E111	40.000	3	4-5

NATURAL				
Seashell	B154	25.000	4	4
Cloudy Sky	B155	25.000	4-5	4
Aged Ivory	B156	25.000	4	4
Umbra	B157	25.000	4-5	4
Off-White	B193	25.000	5	4
Dark Brown	B194	25.000	5	4

NESSO				
Almond NEW	E70	12.000	3	4-5
Ochre Mist NEW	E71	12.000	3	4-5
Carbon Sky NEW	E72	15.000	3	4-5
Sky Mist NEW	E73	15.000	3	4-5
Ice Blue NEW	E74	15.000	3	4-5
Leaf NEW	E75	15.000	3	4-5
Sunset NEW	E76	15.000	3	4-5

FABRIC PROPERTIES

PROPRIÉTÉS DES TISSUS - STOFFEIGENSCHAPPEN

	Code	Category	Composition	Weight (g/m ²)
RUSTIC WEAVE				
Dark Grey	B140	Cat. E	Solution dyed acrylic	400
Oyster	B143	Cat. E	Solution dyed acrylic	400
Cord	B144	Cat. E	Solution dyed acrylic	470
Ice Grey	B146	Cat. E	Solution dyed acrylic	470
Black	B147	Cat. E	Solution dyed acrylic	400
Abricot	B150	Cat. E	Solution dyed acrylic	400
Brown	B151	Cat. E	Solution dyed acrylic	400
Fresco	B152	Cat. E	Solution dyed acrylic	400
Lagoon	B153	Cat. E	Solution dyed acrylic	400
NARAM				
Pearl	NEW F19	Cat. F	Solution dyed acrylic	1.360
Almond	NEW F20	Cat. F	Solution dyed acrylic	1.360
Warm Cotton	NEW F21	Cat. F	Solution dyed acrylic	1.360
Oyster	NEW F80	Cat. F	Solution dyed acrylic	971
Herb	NEW F81	Cat. F	Solution dyed acrylic	971
Rosemary	NEW F82	Cat. F	Solution dyed acrylic	971
Frost	NEW F84	Cat. F	Solution dyed acrylic	971
Denim	NEW F85	Cat. F	Solution dyed acrylic	971
Indigo	NEW F86	Cat. F	Solution dyed acrylic	971
Moss	NEW F87	Cat. F	Solution dyed acrylic	971
Verdant	NEW F88	Cat. F	Solution dyed acrylic	971
Ochre	NEW F89	Cat. F	Solution dyed acrylic	971
Copper	NEW F90	Cat. F	Solution dyed acrylic	971
Merlot	NEW F91	Cat. F	Solution dyed acrylic	971
Cerise	NEW F92	Cat. F	Solution dyed acrylic	971
SIVA				
Cotton White	NEW F50	Cat. F	Solution dyed acrylic	700
SUJÀN				
Hemp	F01	Cat. F	Solution dyed acrylic	1.000
Moss	F02	Cat. F	Solution dyed acrylic	1.000
Ochre	F04	Cat. F	Solution dyed acrylic	1.000
Nature Grey	NEW F17	Cat. F	Solution dyed acrylic	971
BATYLINE				
White	00		Batylite®	
Silkgrey	71		Batylite® Canatex	
Wengé	89		Batylite®	
PAVILION & PURE CABANA				
Sunscape Oyster	S54		98% Polyester 2% hemp	600
Sunscape Nature Grey	S64		98% Polyester 2% hemp	600
Sunscape Stone	S70		98% Polyester 2% hemp	600
Velum				
Velum Oyster	V54		Sunbrella® Solution dyed acrylic	165
Velum Nature Grey	V64		Sunbrella® Solution dyed acrylic	165
Velum Stone	V70		Sunbrella® Solution dyed acrylic	165

Code	Abrasion Resistance Martindale	Colour fastness to UV scale of 1-5	Pilling scale of 1-5	
RUSTIC WEAVE				
Dark Grey	B140	12.000	4	3-4
Oyster	B143	12.000	4	3-4
Cord	B144	21.000	4	3-4
Ice Grey	B146	21.000	4	3-4
Black	B147	12.000	4-5	3-4
Abricot	B150	12.000	3-4	3-4
Brown	B151	12.000	4-5	3-4
Fresco	B152	12.000	3-4	3-4
Lagoon	B153	12.000	4	3-4
NARAM				
Pearl	NEW F19	25.000	4-5	4
Almond	NEW F20	25.000	4-5	4
Warm Cotton	NEW F21	25.000	4-5	4
Oyster	NEW F80	30.000	3	4
Herb	NEW F81	30.000	3	4
Rosemary	NEW F82	30.000	3	4
Frost	NEW F84	30.000	3	4
Denim	NEW F85	30.000	3	4
Indigo	NEW F86	30.000	3	4
Moss	NEW F87	30.000	3	4
Verdant	NEW F88	30.000	3	4
Ochre	NEW F89	30.000	3	4
Copper	NEW F90	30.000	3	4
Merlot	NEW F91	30.000	3	4
Cerise	NEW F92	30.000	3	4
SIVO				
Siva Cotton White	NEW F50	25.000	3-4	4
SUJÀN				
Hemp	F01	5.000	4	3-4
Moss	F02	5.000	4	3-4
Ochre	F04	5.000	4	3-4
Nature Grey	NEW F17	5.000	4	3-4
BATYLINE				
White	00	120.000	4	-
Silkgrey	71	120.000	4	-
Wengé	89	120.000	4	-
PAVILION & PURE CABANA				
Sunscape Oyster	S54	>40.000	4	-
Sunscape Nature Grey	S64	>40.000	4	-
Sunscape Stone	S70	>40.000	4	-
Velum Oyster	V54	40.000	4-5	-
Velum Nature Grey	V64	40.000	4-5	-
Velum Stone	V70	40.000	4-5	-

LEGEND FABRIC PROPERTIES

LÉGENDE PROPRIÉTÉS DES TISSUS - LEGENDE STOFFEIGENSCHAPPEN

Abrasion resistance: fabric's ability to withstand surface wear from rubbing.

Martindale test

Fabric is mounted flat and rubbed in a figure eight-like motion using an abrasive surface. The number of cycles endured before the fabric shows an objectionable change in appearance is counted and determines the fabric's abrasion rating.
20.000 = general contract upholstery
40.000 = heavy duty upholstery

Colour fastness

The fabrics are tested for UV resistance with an aging accelerator in compliance with ISO standard 4892-2 for 5.000 hours and outdoors in Florida, Indonesia and Belgium. Based on these tests the fabrics are awarded a maximum score of 5.

Pilling

The fabric's propensity to pilling. Maximum score is 5 (= least inclined).

Résistance à l'abrasion: la résistance à l'usure induite par le frottement de textiles.

Test Martindale

Le tissu est monté à plat et frotté dans un mouvement en forme huit en utilisant un abrasif. Le nombre de cycles endurés avant que le tissu ne montre un changement d'aspect sensible est compté et détermine le taux d'abrasion du tissu.
20.000 = tissu à usage général dans le secteur contrat
40.000 = tissu à usage intensif

Solidité à la lumière aux intempéries

Tous les tissus sont testés aussi par nous-mêmes pendant 5.000 heures avec un accélérateur de vieillissement en conformité avec la norme ISO 4892-2 et à l'extérieur en Floride, Indonésie et la Belgique. Le score maximal attribué est 5.

Pilling

La propension du tissu au boulochage. Le score maximal est 5 (= le moins incliné).

Slijtvastheid: geeft de weerstand van de stof aan tegen slijtage door wrijving.

Martindale test

Over de strak getrokken stof wordt met behulp van een schuuroppervlak gewreven in een achtvorm. Het aantal cycli dat de stof ondergaat voordat er merkbare slijtage optreedt wordt geteld en bepaalt de slijtvastheid.
20.000 = algemene contract stoffering
40.000 = stoffering voor intensief gebruik

Kleurvastheid bij ververing

We testen de stoffen zelf ook nog op UV-bestendigheid met een verouderingsversneller gedurende 5.000 uren volgens de ISO standaard 4892-2 en op buitenlandse locaties in Florida, Indonesië en België.
Op basis hiervan geven we een score van maximaal 5.

Pilling

De neiging van de stof tot pillen. De maximum score is 5 (= minste neiging).

**INFORMATION**

Aluminium is a non-ferrous metal, which combines great mechanical rigidity with light weight. This makes it especially suitable for furniture. If treated correctly, it has a good resistance to corrosion. By powdercoating aluminium, this corrosion resistance can even be enhanced. After a chemical pre-treatment, an epoxy powder is applied statically and baked. Tribù always uses European, ultra-durable and scratch-resistant polyester powdercoatings that guarantee a UV-resistance of 15 years. For certain collections (Branch & Illum) parts of the frame are die-cast under high pressure which results in a seamless and extremely solid frame. Additionally, an extra epoxy primer coat is applied for these collections.

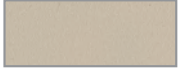
**MAINTENANCE**

Powder coated aluminium is easy to clean with clear water and a pH-neutral fluid detergent. Stubborn stains can be removed with Coated aluminium & stainless steel Cleaner (p. 206). If necessary, use a soft brush to remove the dirt from the pores. To protect the frame against the adhesion of dirt, Coated aluminium & stainless steel Protector (p. 206) can be used which applies an invisible protective film.

**INFORMATION**

L'aluminium est un métal non ferreux qui combine une grande rigidité mécanique à un faible poids. Il convient ainsi idéalement pour la fabrication de mobilier. Moyennant un traitement correct, l'aluminium présente une résistance élevée à la corrosion. Cette résistance à la corrosion peut encore être optimisée en appliquant un laquage en poudre à l'aluminium. Après un prétraitement chimique, une poudre époxy est appliquée par voie statique, puis cuite.

Tribù utilise toujours des laques polyester en poudre européennes ultra durables, avec une résistance aux UV de 15 ans. Dans certaines collections (Branch & Illum), les pièces en aluminium sont moulées sous haute pression, ce qui crée un cadre sans soudures et très robuste. Pour ces collections, on utilise en plus une couche additionnelle de primer époxy.

ENTRETIEN

L'aluminium est facile à entretenir avec de l'eau pure et un détergent liquide à pH neutre. Vous pouvez éliminer les taches récalcitrantes avec de l'Coated aluminium & stainless steel Cleaner (p. 206). Si nécessaire, employez une brosse douce pour éliminer les saletés dans les pores. Pour protéger le cadre contre l'incrustation de saletés, on peut employer Coated aluminium & stainless steel Protector (p. 206), qui applique une couche de protection invisible.

INFORMATIE

Aluminium is een non-ferro metaal dat een hoge mechanische stijfheid combineert met een licht gewicht. Dit maakt het bijzonder geschikt voor meubilair. Indien correct behandeld, heeft aluminium een grote weerstand tegen corrosie. Door aluminium te poederlakken kan deze corrosiebestendigheid nog verder opgedreven worden. Na een chemische voorbehandeling wordt een epoxy poeder statisch toegepast en gebakken. Tribù gebruikt steeds Europese, ultra-durable en krasbestendige polyesterpoederlakken met een UV-bestendigheid van 15 jaar. Bij bepaalde collecties (Branch & Illum) worden delen van het aluminium onder hoge druk spuitgegoten waardoor een naadloos en zeer sterk frame ontstaat. Bij deze collecties wordt bovendien een extra laag epoxy primer toegepast.

ONDERHOUD

Aluminium is makkelijk te onderhouden met zuiver water en een pH-neutraal, vloeibaar detergent. Hardnekkige vlekken kan u verwijderen met Coated aluminium & stainless steel Cleaner (pag. 206). Gebruik indien nodig een zachte borstel om vuil uit de poriën te verwijderen. Om het frame te beschermen tegen vasthechten van vuil, kan Coated aluminium & stainless steel Protector (p. 206) gebruikt worden dat een onzichtbare beschermlaag aanbrengt.

BRANCH, FORUM, ILLUM, NATAL ALU, PAVILION, SENJA & TOSCA



INFORMATION

Batyline® is a polyester fibre which is coated with solution dyed PVC and then woven. The fibres are then melted together to create an extremely stretch and tear-resistant fabric that keeps its shape perfectly. Apart from its exceptional mechanical strength, it has a high chemical resistance. The synthetic coating guarantees an extremely high weather and UV-resistance. The fact that no moisture is absorbed, results in rapid drying, maximum stain and mould-resistance and simple cleaning. The most important feature is its pliancy and optimal seating comfort.

Canatex® is the marriage between Batyline® and a natural fibre, hemp. The combination of the two leads to more subtle colours and a natural touch, leaving all the technological advantages of the product untouched.

MAINTENANCE

Batyline® is easy to clean with clear water and a pH-neutral soap. Stubborn stains can be removed with Synthetics Super Cleaner (p. 208). If necessary, use a soft brush to remove dirt from the pores. Do not use acid, alkaline or chlorinated products that can harm the hardware of your furniture.

For extra protection we recommend Synthetics Protector (p. 208) which applies an invisible film and reduces the adhesion of dirt.

INFORMATION

Batyline® est une fibre polyester qui est recouverte d'une couche de PVC, puis tissée. Ces fibres sont ensuite fondues ensemble pour créer une toile extrêmement résistante à la déchirure, qui conserve parfaitement sa forme. En plus de ses résistances mécaniques exceptionnelles, Batyline® possède aussi une résistance chimique élevée. La couche synthétique de PVC garantit une résistance extrême aux intempéries et UV. Comme Batyline® n'absorbe aucune humidité, il sèche très rapidement et est insensible aux taches et aux moisissures. En outre, il est très flexible, ce qui assure un grand confort d'assise.

Canatex® est une variante spéciale qui combine le Batyline® ordinaire avec la fibre naturelle de chanvre. Cette combinaison produit des coloris plus subtils et un aspect visuel et tactile naturel, mais n'affecte en rien les avantages technologiques du produit.

ENTRETIEN

Batyline® est très facile à entretenir et peut être nettoyé simplement avec de l'eau pure et un détergent liquide à pH neutre. Les taches récalcitrantes peuvent être éliminées avec le Synthetics Super Cleaner (p. 208). Si nécessaire, employez une brosse douce pour éliminer les saletés dans les pores. N'utilisez pas de produits acides, alcalins ou contenant du chlore, qui risquent d'attaquer la carcasse de votre meuble.

Pour une protection supplémentaire, nous recommandons du Synthetics Protector (p. 208) qui applique un film invisible réduisant l'incrustation de saletés.

INFORMATIE

Batyline® is een polyestervezel die gecoat wordt met een laag PVC en daarna geweven. De vezels worden daarna samengesmolten om een extreem scheurbestendige doek te creëren die zijn vorm perfect behoudt. Naast zijn buitengewoon mechanische sterktes, heeft Batyline® ook een hoge chemische weerstand. De synthetische pvc laag garandeert een extreem hoge weer- en UV-bestendigheid. Omdat Batyline® geen vocht absorbeert, droogt het erg snel en is het vlek- en schimmelbestendig. Bovendien is het ook erg flexibel waardoor het zitcomfort erg aangenaam is.

Canatex® is een speciale variant die gewone Batyline® combineert met de natuurlijke hennepvezel. Deze combinatie geeft meer subtiele kleuren en een natuurlijke look & feel, waarbij alle technologische voordelen van het product behouden blijven.

ONDERHOUD

Batyline® is zeer onderhoudsvriendelijk en kan makkelijk gereinigd worden met zuiver water en een pH-neutraal, vloeibaar detergent. Hardnekkige vlekken kunnen verwijderd worden met Synthetics Super Cleaner (p. 208). Gebruik indien nodig een zachte borstel om vuil uit de poriën te verwijderen. Gebruik geen zure, basische of chloorhoudende producten die de hardware van uw meubel kunnen aantasten.

Voor extra bescherming raden we Synthetics Protector (p. 208) aan die een onzichtbare film aanbrengt die de aanhechting van vuil vermindert.



INFORMATION

In the world of metals, brass is a distinctive element that has enriched our lives for centuries. Being an alloy of copper and zinc, it is highly malleable and therefore remarkably versatile. Its frequent use in the marine industry also underlines its sustainable quality.

But one of its captivating charms is its capacity to transform over time. When encountering the elements of its surroundings like air, moisture and various environmental factors, a chemical reaction leads to the formation of a thin outer layer, known as patina.

The intrinsic qualities and warm aesthetics of the brass make it the ideal material for our beautifully crafted hardware, detailing the table top and discreetly conjoining multiple SURO dining tables.

MAINTENANCE

Brass is easy to clean with clear, fresh water and a pH-neutral liquid detergent. Always use a soft, clean cloth. Over time, brass will develop a sophisticated patina, ranging from greens and blues to a warm brown.

Substances, especially salty and acidic ones like juice, coffee, red wine, balsamic vinegar, bird droppings and leaves, leave no stains but do influence the nuances of the brass' surface. For minimal impact, immediately wipe off all substances.

When cleaning, please avoid intense rubbing to maintain the corroded, matte appearance. Once the brass acquires a shiny glow, the only way to recover its elegantly aged appearance, is to be patient.

INFORMATION

Dans le monde des métaux, le laiton est un élément distinctif qui embellit notre vie depuis des siècles.

Alliage de cuivre et de zinc, il est très malléable et donc hautement polyvalent. Son utilisation fréquente dans l'industrie maritime souligne en outre ses qualités durables.

Toutefois, l'un de ses charmes les plus captivants est sa capacité à se transformer au fil du temps. Au contact des éléments de son environnement, tels que l'air, l'humidité et divers facteurs environnementaux, une réaction chimique conduit à la formation d'une fine couche extérieure, appelée patine.

Les qualités intrinsèques et l'esthétique chaleureuse du laiton se prêtent parfaitement à la réalisation de notre raccord, détaillant le plateau de la table et joignant harmonieusement plusieurs tables à manger SURO.

ENTRETIEN

Le laiton est facile à nettoyer avec de l'eau claire et un détergent liquide au pH neutre. Utilisez toujours un chiffon doux et propre.

Avec le temps, le laiton acquiert une patine sophistiquée, allant des verts et des bleus à un brun chaud. Les substances, notamment salées et acides comme le jus, le café, le vin rouge, le vinaigre balsamique, les fientes d'oiseaux et les feuilles, ne laissent pas de taches, mais altèrent les nuances de la surface du laiton. Pour limiter les effets, essuyez immédiatement toutes les substances.

Pendant le nettoyage, évitez de frotter de manière trop vigoureuse afin de conserver l'aspect corrodé et mat. Une fois que le laiton a acquis un éclat brillant, la seule façon de retrouver son aspect patiné élégant est de s'armer de patience.

INFORMATIE

In de wereld van metalen is messing een karakteristiek element dat onze levens al eeuwenlang verrijkt. Als legering van koper en zink is het materiaal zeer vormbaar en dus opmerkelijk veelzijdig. Het frequente gebruik in de maritieme industrie onderstreept de duurzame kwaliteit ervan.

Maar zijn fascinerende charme ligt ook in het vermogen om in de loop van de tijd te transformeren. Bij contact met natuurlijke omgevingselementen zoals lucht, vocht en diverse weersomstandigheden ontstaat een chemische reactie die een dunne buitenlaag vormt, bekend als patina.

De intrinsieke kwaliteiten en warme esthetiek maken van messing het ideale materiaal voor het prachtig ontworpen beslag en discrete koppelingselement van onze SURO tafels.

ONDERHOUD

Messing is gemakkelijk proper te maken met helder kraanwater en een vloeibaar pH-neutraal reinigingsmiddel. Gebruik altijd een zachte, zuivere doek.

Met de tijd ontwikkelt het messing een gesofisticeerd patina, gaande van groene en blauwe tinten tot een warm bruin. Substanties zoals zoute en zure sappen (koffie, rode wijn, balsamico azijn), vogeluitwerpselen en bladeren maken geen permanente vlekken, maar hebben wel een invloed op de nuances van het oppervlak. Veeg voor een minimale impact alle substanties onmiddellijk weg.

Vermijd bij reiniging intensief wrijven om het gecorrodeerde, matte uiterlijk te behouden. Zodra het messing een glans vertoont, is geduld de enige manier om het elegant verouderde patina terug te krijgen.



INFORMATION

Canax® is a unique combination of natural hemp and synthetic fibres. Unbreakable polyester fibres give strength and stability. PVC makes the Canax® stain repellent and resistant to outside influences, fungi, frost and UV radiation. The hemp finally, gives the material a surprisingly matte look and a natural touch, almost like leather. Canax® is also a CO2 positive product. As hemp is a natural product, differences in colour and structure may appear, giving the furniture - together with the hand weaving - a unique craft appearance, which cannot be regarded as a fault.

MAINTENANCE

Canax® requires hardly any maintenance and is easy to clean with clear water and a PH neutral soap. Stubborn stains and persistent green deposit can be removed with Synthetics Super Cleaner (p. 208). Use a soft brush to clean between the weave.

For extra protection we recommend Synthetics Protector (p. 208) which applies an invisible film and reduces the adhesion of dirt.

INFORMATION

Canax® est une combinaison unique de chanvre naturel et de fibres synthétiques. Les fibres polyester incassables garantissent la résistance et la stabilité. Le PVC rend le matériau grand-teint, résistant aux moisissures, au gel et aux taches. Enfin, le chanvre crée un aspect mat surprenant et une sensation naturelle presque comparable à celle du cuir. En outre, le Canax® est un produit CO2 positif. Comme le chanvre est un produit naturel, de légères différences de couleur et de structure peuvent apparaître. Avec le tissage manuel, elles confèrent au meuble un aspect artisanal unique, qui ne peut pas être considéré comme un défaut.

ENTRETIEN

Canax® est très facile à entretenir et peut être nettoyé simplement avec de l'eau pure et un détergent liquide à pH neutre. Les taches récalcitrantes peuvent être éliminées avec le Synthetics Super Cleaner (p. 208). Utilisez une brosse douce pour éliminer les saletés entre le tissage.

Pour une protection supplémentaire, nous recommandons du Synthetics Protector (p. 208) qui applique un film invisible réduisant l'incrustation de saletés.

INFORMATIE

Canax® is een unieke combinatie van natuurlijke hennep en kunstofvezels. Onbreekbare polystervezels zorgen voor sterkte en stabiliteit. PVC maakt het materiaal kleurvast, schimmel-, vorst- en vlekbestendig. De hennep ten slotte, zorgt voor een verrassend mat uitzicht en een natuurlijk gevoel, bijna vergelijkbaar met leder. Canax® is bovendien een CO2 positief product. Aangezien hennep een natuurlijk product is, kan er een licht verschil in kleur en structuur ontstaan. Samen met het handweven, geeft dit een uniek, artisanaal uitzicht aan het meubel dat niet aanzien kan worden als een fout.

ONDERHOUD

Canax® is zeer onderhoudsvriendelijk en kan makkelijk gereinigd worden met zuiver water en een pH-neutraal, vloeibaar detergent. Hardnekkige vlekken kunnen verwijderd worden met Synthetics Super Cleaner (p. 208). Gebruik een zachte borstel om vuil tussen de weving te verwijderen.

Voor extra bescherming raden we Synthetics Protector (p. 208) aan die een onzichtbare film aanbrengt die de aanhechting van vuil vermindert.

AMANU, ILLUM, NOX, OTTO, T-TABLE, TOSCA & UKIYO



INFORMATION

Ceramic has been used for centuries for all kinds of purposes. With its unique characteristics it is the ideal material for outdoor table tops. Ceramic is UV-resistant, frost proof, extremely scratchproof and completely stain-repellent. The ceramic used by Tribù is coloured in the mass and guarantee years of carefree pleasure. The raw materials are selected very carefully by suppliers from Western and Southern Europe only. Every top is unique. For example, the Scisto colour may show subtle veins, but this is not the case for every top. The ceramic table tops are slightly bended so water can flow off.

MAINTENANCE

Ceramic is very easy to maintain with clear water and a pH-neutral soap. Stubborn stains can be removed with Ceramic, Lava Stone & Glass Cleaner (p. 207). To protect the ceramic, Ceramic, Lava Stone & Glass Protector (p. 207) can be used. This applies a highly water and soiling repellent coating, which also makes the surface brighter, smoother and easier to clean.

INFORMATION

La céramique est utilisée depuis des siècles dans les applications les plus diverses et constitue le matériau idéal pour les plateaux de table destinés à l'extérieur. Elle est extrêmement résistante aux taches, acides, griffes, au feu, au gel et aux rayons UV. La céramique employée par Tribù est complètement teintée dans la masse et vous garantit des années de plaisir sans le moindre souci. Les matières premières sont sélectionnées très soigneusement par des fournisseurs d'Europe Occidentale et du Sud. Chaque plateau est unique. Par exemple, sur la variante Scisto des fines veines peuvent figurer, mais ce n'est pas le cas pour chaque dessus de table. Les plateaux de table en céramique sont légèrement convexes de sorte que l'eau puisse s'en écouler.

ENTRETIEN

La céramique est facile à entretenir avec de l'eau pure et un détergent liquide à pH neutre. Les taches récalcitrantes peuvent être éliminées avec le Ceramic, Lava Stone & Glass Cleaner (p. 207). Le Ceramic, Lava Stone & Glass Protector (p. 207) applique une couche protectrice invisible qui est hydrofuge et antitaches, et rend la surface plus claire, plus lisse et plus facile à nettoyer.

INFORMATIE

Keramiek wordt al eeuwenlang gebruikt voor allerlei doeleinden en is het ideale materiaal voor tafelbladen voor buitengebruik. Het is uiterst bestand tegen vlekken, zuren, krassen, vuur, vorst en UV-stralen. De keramiek die Tribù gebruikt, is volledig in de massa gekleurd en garandeert u jarenlang plezier zonder zorgen. De selectie van de grondstoffen gebeurt uiterst zorgvuldig door enkel West- en Zuideuropese leveranciers waarbij elk blad uniek is. De Scisto variant kan bijvoorbeeld subtiele aders vertonen, maar dit is niet voor elk blad het geval. Onze keramische tafelbladen zijn lichtjes gebogen zodat het water eraf kan vloeien.

ONDERHOUD

Keramiek is eenvoudig te onderhouden met zuiver water en een pH-neturaal, vloeibaar detergent. Hardnekkige vlekken kunnen verwijderd worden met Ceramic, Lava Stone & Glass Cleaner (p. 207). Ceramic, Lava Stone & Glass Protector (p. 207) brengt een onzichtbare bescherm laag aan die waterafstotend en vlekwerend werkt en het oppervlak helderder, gladder en makkelijker om te reinigen maakt.

**INFORMATION**

The durability and strength of tempered glass make it an excellent choice for any outdoor application. Being coloured throughout, the glass's hue remains vibrant and consistent, even with prolonged outdoor exposure. Each panel features polished edges, providing a refined finish that is also child-friendly. The unique texture of the surface diffuses and scatters light in a playful manner, resulting in an elegant visual effect.

MAINTENANCE

Glass surfaces are easy to clean with pure water or a glass cleaner and a microfibre cloth, preferably when the glass has cooled. On the textured surface, deposits and dirt may remain. Wipe these away with a microfibre cloth as quickly as possible, ensuring you cover the entire surface and edges. For stubborn stains, use our Glass, Ceramic & Lava Stone Cleaner (p. 207). Abrasive cleaners are strongly discouraged. Glass is not impervious and may develop micro-scratches over time due to ageing.

The Glass, Ceramic & Lava Stone Protector (p. 207) protects the glass surface against water rings and the adherence of stubborn dirt, slows the natural ageing of the material, and facilitates effortless cleaning.

Do not place pottery or cement-based vases or pots on the glass, as they may damage the surface upon contact with water. Always use a coaster for ceramic or porcelain plates, pots, and cutlery. Avoid placing hot pots and candles directly on the glass or use an insulating coaster.

INFORMATION

La durabilité et la solidité du verre trempé en font un excellent choix pour toute application extérieure. Grâce à la coloration dans la masse, le verre reste vif et d'une couleur constante lors d'une utilisation prolongée à l'extérieur. Chaque panneau est doté de bords polis, une finition esthétiquement attrayante qui est également conviviale pour les enfants. La texture unique de la surface diffuse et réfracte la lumière de manière ludique, produisant un effet visuel élégant.

ENTRETIEN

Les panneaux en verre sont faciles à nettoyer avec de l'eau pure ou un nettoyeur pour vitres et un chiffon en microfibre, de préférence lorsque le verre a refroidi. Sur la surface texturée, des dépôts et de la saleté peuvent rester – essuyez-les dès que possible avec un chiffon en microfibre jusqu'au bord complet. Pour les taches tenaces, utilisez notre Nettoyeur pour Verre, Céramique et Pierre de Lave (p. 207). Les abrasifs sont fortement déconseillés. Le verre n'est pas invulnérable et peut montrer des micro-dommages avec le temps.

Le Protecteur pour Verre, Céramique et Pierre de Lave (p. 207) protège la surface en verre contre les anneaux d'eau et l'adhérence des saletés tenaces, ralentit le vieillissement naturel du matériau et facilite le nettoyage.

Ne placez pas de vases ou de pots en terre cuite ou en ciment sur le verre, car ils peuvent endommager la surface au contact de l'eau. Utilisez toujours un dessous-de-plat pour les assiettes, pots et couverts en céramique ou en porcelaine. Évitez les pots chauds et les bougies ou utilisez un dessous isolant.

INFORMATIE

De duurzaamheid en sterkte van gehard glas maken het een uitstekende keuze voor elke buitentoepassing. Door de kleuring in de massa blijft het glas levendig en consistent van kleur bij langdurig gebruik buiten. Elk blad is voorzien van gepolijste randen, een esthetisch aantrekkelijke afwerking die ook kindvriendelijk is. De unieke textuur van het oppervlak breekt en verspreidt het licht op een speelse manier, met een elegant visueel effect als resultaat.

ONDERHOUD

Glazen bladen zijn eenvoudig te reinigen met zuiver water of een ruitenreiniger en een microvezeldoek, bij voorkeur wanneer het glas is afgekoeld. Op het gestructureerde oppervlak kunnen neerslag en vervuiling achterblijven – neem deze zo snel mogelijk af met een microvezeldoek tot over de volledige rand. Gebruik voor hardnekkige vlekken onze Glass, Ceramic & Lava Stone Cleaner (p. 207). Schuurmiddelen zijn sterk afgeraden. Glas is niet onaantastbaar en kan door veroudering microbeschadigingen vertonen.

De Glass, Ceramic & Lava Stone Protector (p. 207) beschermt het glazen blad tegen wateringen en de aanhechting van hardnekkig vuil, vertraagt de natuurlijke veroudering van het materiaal en vergemakkelijkt eenvoudig reinigen.

Plaats geen aardewerk of cementgebonden vazen of potten op het glas, omdat deze schade aan het oppervlak kunnen veroorzaken bij contact met water. Gebruik altijd een onderlegger bij keramische of porseleinen borden, potten en bestek. Vermijd hete potten en kaarsen of gebruik een isolerende onderzetter.

GLAZED LAVA STONE

PIERRE DE LAVE ÉMAILLÉE - GEGLAZUURDE LAVASTEEN

HEXAGON, NOX, SENJA, TAIRU & T-TABLE

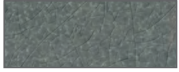

INFORMATION

Glazed lava is a unique and handcrafted material that expresses the natural aspect of lava stone. It offers the inherent strength of the volcanic stone combined with all the surface qualities associated with enamels. The density of the lava rock stone allows it to be used in one large piece. Once molten lava, the stone can withstand the very high temperatures used in the glazing process. Glazing makes sure the finished product is UV stable, impervious to water and resistant to heat, frost, chemicals and stains. It is very easy to maintain. Tribù chose for a subtle craquelé effect. As it is a natural product, you will find "aesthetic imperfections" that are just peculiar characteristic of both natural stone and handcrafted finishing. No table top in glazed lava stone will therefore be the same, making it so unique and attractive.

MAINTENANCE

Glazed lava stone is easy to maintain with clean water and a pH neutral liquid detergent. Possible stains can be removed with Ceramic, Lava Stone & Glass Cleaner (p. 207). To protect the surface we recommend Ceramic, Lava Stone & Glass Protector (p. 207) which fills the micro pores so dirt particles won't attach to the surface and will be rain-washed.

INFORMATION

La pierre de lave émaillée est un matériau unique et artisanal qui souligne de superbe manière l'aspect naturel de la pierre de lave. Elle allie la robustesse de la pierre de lave et les avantages de l'émail.

Grâce à la haute densité de la pierre de lave, elle peut être utilisée en grands morceaux. Originellement de la lave en fusion, la pierre est donc parfaitement adaptée pour supporter les températures élevées du processus d'émaillage. La couche d'émail permet au matériau de résister à l'eau, au gel, à la chaleur, aux taches et aux rayons UV. Par ailleurs, elle offre une résistance élevée aux produits chimiques et ne nécessite presque aucun entretien.

Tribù a opté pour un subtil effet craquelé. Comme il s'agit d'un matériau naturel, il peut présenter quelques « imperfections esthétiques ». Dès lors, il n'existe pas deux tablettes en pierre de lave émaillée qui soient totalement identiques. Et tout ce qui est unique attire.

ENTRETIEN

La pierre de lave émaillée se nettoie facilement à l'eau, avec un détergent liquide au pH neutre. Pour éliminer les taches éventuelles, il convient d'employer du Ceramic, Lava Stone & Glass Cleaner (p. 207). En guise de protection, nous recommandons Ceramic, Lava Stone & Glass Protector (p. 207), un produit qui bouche les micropores du matériau, de sorte que la saleté ne peut s'accrocher à la surface et sera éliminée par la pluie.

INFORMATIE

Geglazuurde lavasteen is een uniek en ambachtelijk bewerkt materiaal dat het natuurlijke aspect van lavasteen op een prachtige manier benadrukt. Het combineert de sterkte van lavasteen met de voordelen van glazuren. Dankzij de hoge densiteit van lavasteen kan het in grote stukken gebruikt worden. Omdat het ooit gesmolten lava was, kan de steen perfect de hoge temperaturen nodig tijdens het glazuurproces weerstaan. De glazuurlaag zorgt ervoor dat het materiaal erg water-, vorst-, hitte-, vlek- en UV bestendig is. Het heeft een hoge weerstand tegen chemicaliën en vergt bijna geen onderhoud.

Tribù koos voor een subtiel craquelé effect. Omdat het een natuurlijk product is, zijn 'esthetische imperfecties' eigen aan het materiaal. Geen enkel tafelblad in geglazuurde lavasteen zal dus hetzelfde zijn. Net dat maakt het zo uniek en aantrekkelijk.

ONDERHOUD

Geglazuurde lavasteen is eenvoudig te reinigen met zuiver water en een pH neutraal, vloeibaar detergent. Eventuele vlekken kunnen verwijderd worden met Ceramic, Lava Stone & Glass Cleaner (p. 207). Als bescherming raden we Ceramic, Lava Stone & Glass Protector (p. 207) aan. Dit product vult de microporiën van het materiaal waardoor vervuiling zich niet kan hechten aan het oppervlak en door een gewone regenbui weg gewassen zal worden.



INFORMATION

Granite is an igneous rock that is formed deep below the earth's surface by compression. Because the pressure below the Earth's surface is so high, granite is immensely hard. After diamond, it is the strongest rock species on earth. Granite is little porous and has good scratch resistance. Germs and fungi have no chance. The name granite comes from the Latin 'granus', which means 'grain'. This 'granular' look is typical of granite. No two table tops will be ever alike. Tribù granite table tops have a 'leather touch' finish. This soft, brushed finish accentuates the natural colour of the material and gives a unique, soft touch.

MAINTENANCE

Granite can be cleaned with water and pH neutral soap. Granite Cleaner/Protector (p. 209) refreshes the gloss of the granite and makes it water and stain repellent. Do not use aggressive detergents as they attack the lime in the stone.

INFORMATION

Le granite est une roche magmatique formée profondément sous la surface de la terre par compression. Comme la pression à cette profondeur est tellement élevée, le granite est exceptionnellement dur. Après le diamant, c'est le type de roche le plus dur sur terre. Le granite est peu poreux et présente une bonne résistance aux rayures. Les bactéries et moisissures n'y ont aucune chance. Granite vient du latin « granus », qui signifie « grain ». Cet aspect « granulaire » est typique pour le granite. Il n'y a jamais deux plateaux de table identiques. Les plateaux de table en granite de Tribù présentent une finition « leather touch ». Cette finition brossée douce accentue la couleur naturelle du matériau et donne une sensation unique et douce au toucher.

ENTRETIEN

Le granite peut être nettoyé avec de l'eau pure et un savon à pH neutre. Granite Cleaner/Protector (p. 209) rafraîchit également le brillant du granite, et le rend résistant à l'eau et aux taches. N'employez pas de détergents agressifs étant donné que ceux-ci peuvent attaquer le calcaire dans la pierre.

INFORMATIE

Graniet is een stollingsgesteente dat diep onder het aardoppervlak wordt gevormd door compressie. Omdat de druk onder het aardoppervlak zo hoog is, is graniet ontzettend hard. Na diamant is het de sterkste steensoort op aarde. Graniet is weinig poreus en heeft een goede krasbestendigheid. Bacteriën en schimmels maken geen kans. Graniet komt van het Latijnse 'granus', wat 'korrel' betekent. Deze 'granulaire' look is typisch voor graniet. Geen twee tafelbladen zullen ooit gelijk zijn.

ONDERHOUD

Graniet kan gereinigd worden met zuiver water en pH neutrale zeep. Granite Cleaner/Protector (p. 209) frist de glans van het graniet op en maakt het water- en vlekafstotend. Gebruik geen agressieve detergents aangezien ze de kalk in de steen kunnen aantasten.



INFORMATION

Our tables in lightened concrete do not contain gravel, like ordinary concrete, but a mix of quartz granulates and fibres, making the material a lot lighter. Nevertheless, it is very sturdy* and durable. Frost and heat have no influence and the colouring in the mass ensures that your table will retain its original colour for a long time. Each furniture piece is hand-finished by an Italian craftsman, giving it a unique patina and a smooth surface texture.



However, lightened concrete is a natural product and sensitive to stains. Despite the fact that we treat our tables with a concrete conditioner that reduces stains and moisture absorption, some caution is required, as with natural stone and marble.

*We recommend a maximum load of 10 kg on the coffee table tops.

MAINTENANCE

For daily cleaning, dip a soft, clean cloth in a solution of warm, clear water and a pH-neutral fluid detergent. Rinse thoroughly and let dry. Stains should be wiped off immediately, especially acidic substances (juice, coffee, red wine, balsamic vinegar,...) since they may cause permanent stains. Also bird droppings and leaves may cause permanent stains if not removed immediately. We recommend to use a protective cover if you are not using your table.

Oil, grease and wax stains can be removed by using Tribù Oil, Wax and Grease Remover (p. 210). Do not use corrosive or acidic detergents.

To protect your table, we recommend to use Tribù Lightened Concrete Conditioner (p. 210) regularly. However, this product does not protect against acidic substances. It can also be used for removing stains. Depending on the type of stain and its age, the stain can be completely removed or its intensity reduced.

Lightened concrete contains natural fibers that can surface over time due to temperature fluctuations, which could feel slightly unpleasant to the touch. If this happens, we recommend to lightly hand sand the table top with a sanding disc making circular movements until the surface feels smooth again.

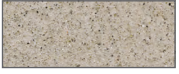

INFORMATION

Nos plateaux de table en béton allégé ne contiennent pas de gravier comme le béton ordinaire, mais un mélange de granulés de quartz et de fibres qui rendent le matériau beaucoup plus léger. Le béton allégé est néanmoins un matériau très solide* et durable. Il est insensible au gel et à la chaleur et, comme il est coloré dans la masse, votre table conservera longtemps sa couleur d'origine. Chaque pièce est finie à la main par un artisan italien, ce qui lui confère une patine unique et une texture de surface lisse.

Le béton allégé est toutefois un produit naturel et sensible aux taches. Malgré le fait que nous prévoyons un produit de conditionnement pour le béton limitant les taches et l'absorption d'humidité, une certaine prudence est de mise, comme avec la pierre naturelle et le marbre.

* La charge maximale des plateaux de tables basses est de 10 kg.

ENTRETIEN

Pour le nettoyage quotidien, plongez un chiffon propre dans une solution d'eau chaude et un détergent liquide au pH neutre. Rincez abondamment et laissez sécher. Des taches doivent être essuyées immédiatement, en particulier les substances acides (jus, café, vin rouge, vinaigre balsamique,...) car elles peuvent provoquer des taches permanentes. Les fientes d'oiseaux et les feuilles peuvent également provoquer des taches permanentes si elles ne sont pas enlevées immédiatement. Nous vous recommandons d'utiliser une housse de protection si vous n'utilisez pas votre table.

Les taches d'huile, de graisse et de cire peuvent être enlevées à l'aide du Tribù Oil, Wax and Grease Remover (p. 210). N'utilisez pas de détergents corrosifs ou acides.

Pour protéger votre table, nous vous recommandons d'utiliser régulièrement du Tribù Lightened Concrete Conditioner (p. 210). Cependant, ce produit ne protège pas contre les substances acides. Il peut également être utilisé pour éliminer les taches. Selon le type de tache et son âge, la tache peut être complètement éliminée ou son intensité réduite.

Le béton allégé contient des fibres naturelles qui pourraient remonter à la surface sous l'effet des changements de température, ce qui peut provoquer une sensation désagréable. Dans ce cas, vous pouvez utiliser un disque de ponçage pour poncer le plateau de table légèrement à la main, en effectuant des mouvements circulaires, jusqu'à ce qu'il soit à nouveau lisse.

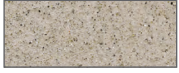

INFORMATIE

Onze tafels uit verlicht beton bevatten geen grind zoals gewoon beton, maar een mix van kwartsgranulaten en vezels waardoor het materiaal een stuk lichter is. Desalniettemin is het zeer stevig* en duurzaam. Vorst en hitte hebben geen invloed en de kleuring in de massa zorgt ervoor dat uw tafel langdurig haar originele kleur zal behouden. Elk stuk wordt met de hand afgewerkt door een Italiaanse vakman, waardoor het een unieke patina en een gladde oppervlaktetextuur krijgt.



Verlicht beton is echter een natuurlijk product en gevoelig voor vlekken. Ondanks het feit dat wij onze tafels voorzien van een betonconditioner die vlekken en vochtopname beperkt, is enige voorzichtigheid geboden, zoals bij natuursteen en marmer.

*Maximale belasting van de tafelbladen van lage salontafels is 10kg.

ONDERHOUD

Dompel voor de dagelijkse reiniging een zachte, propere doek onder in een oplossing van warm, zuiver water en een pH-neutraal vloeibaar reinigingsmiddel. Spoel grondig af en laat drogen. Vlekken dienen onmiddellijk worden afgeveegd, vooral zure stoffen (sap, koffie, rode wijn, balsamico azijn,...) daar ze permanente vlekken kunnen veroorzaken. Ook vogeluitwerpselen en bladeren kunnen permanente vlekken veroorzaken als ze niet onmiddellijk worden verwijderd. We raden u aan een beschermhoes te gebruiken als u uw tafel niet gebruikt.

Olie-, vet- en kaarsvetvlekken kunnen worden verwijderd met Tribù Oil, Wax & Grease Remover (p. 210).

Gebruik geen bijtende of zure reinigingsmiddelen.

Om uw tafel te beschermen, raden wij u aan om regelmatig Tribù Lightened Concrete Conditioner (p. 210) te gebruiken. Dit product beschermt echter niet tegen zure stoffen. Het kan ook gebruikt worden voor het verwijderen van vlekken. Afhankelijk van het soort vlek en de leeftijd kan de vlek volledig worden verwijderd of de intensiteit ervan worden verminderd.

Verlicht beton bevat natuurlijke vezels die onder invloed van temperatuurschommelingen aan de oppervlakte kunnen komen, wat een onaangenaam gevoel kan veroorzaken. In dat geval raden wij aan het blad met de hand licht cirkelvormig op te schuren met een schuurschijfje tot het oppervlak weer glad aanvoelt.

MONSIEUR TRICOT

OUTDOOR LAMPS



INFORMATION

The Monsieur Tricot outdoor lamps are made of a sphere in PMMA thermoplastic with a removable hand crocheted or knitted polypropylene cover.

Standing lamps

- Lamp
 - Dimmable LED, 9-12.6 Volt, Kelvin 2.129
 - 12 hours operational when burning at 100%
- Charging
 - Rechargeable battery
 - Power adaptor with USB-slot, cable included
 - 5 hours of charging time
- Control
 - On/off switch
- Extra
 - Ceiling hook included to turn your standing lamp into a hanging version

Hanging lamps

- Lamp
 - E27/E26 fitting with dimmable LED filament bulb included, Kelvin 2200
 - Connect to local power grid, 220-240 volt.
 - 5 meter cable, mounting bracket, ceiling canopy and wire connector clamps included
 - Please contact a local professional to install a hanging Monsieur Tricot lamp
- Control
 - Use an already available switch or have a local professional install a new switch. Switches cannot be purchased from Tribù

Certificates

- CE (EU + UK), RoHS 2.0 (EU), FCC (USA), IC (Canada), SAA (Australia & New Zealand), RCM (Australia & New Zealand, only for standing lamps), MOC (Israel)
- IK08
- IP65

MAINTENANCE

The knitted cover can easily be removed to be cleaned in a washing machine at 40° (synthetic washing program). Let dry in open air, certainly not in the dryer. Extend the Lebonnet braiding well before drying. Stubborn stains can be removed with Synthetics Super Cleaner (p. 208). Use a microfiber cleaning cloth to clean the lamp. Do not use a scourer, this causes scratches and damages the surface.



INFORMATION

Les lampes d'extérieur de Monsieur Tricot sont composées d'une sphère en thermoplastique PMMA avec une housse removable en polypropylène crocheté à la main ou tricotée.

Lampes sur pied

- Lampe
 - Lampe LED dimmable, 9-12.6 Volt, Kelvin 2.129
 - Autonomie 12 heures lorsque le dimmer est à 100 %
- Chargement
 - Batterie rechargeable
 - Chargeur avec port USB, câble inclus
 - 5 heures de chargement
- Contrôle
 - Bouton on/off
- Extra
 - Crochet de plafond inclus pour transformer votre lampe sur pied en une version suspendue

Lampes à suspendre

- Lampe
 - Douille E27/E26 avec ampoule à incandescence LED incluse, Kelvin 2200.
 - Connexion sur le réseau électrique, 220-230 V
 - Câble de 5 mètres, support de montage, auvent de plafond et pinces de connexion de fil inclus
 - Prenez contact avec un professionnel local pour installer les lampes.
- Mise en fonction
 - Utilisez une prise de la maison (ou demandez à un professionnel local d'installer une nouvelle). Les prises ne sont pas fournies par Tribù.

Certificats

- CE (UE + UK), RoHS 2.0 (UE), FCC (USA), IC (Canada), SAA (Australie & Nouvelle-Zélande), RCM (Australie & Nouvelle-Zélande, uniquement pour les lampes sur pied), MOC (Israël)
- IK08
- IP65

ENTRETIEN

La housse crochetée peut être retirée facilement pour être nettoyée en machine à 40°C (programme synthétique). Laissez-la sécher à l'air, jamais au sèche-linge. Étirez bien le tricot Lebonnet avant de le mettre à sécher. Les taches récalcitrantes peuvent être éliminées avec Synthetics Super Cleaner (p. 208). Utilisez un chiffon en microfibre pour nettoyer la lampe. N'utilisez pas d'éponge à récurer, qui laisse des rayures et endommage la surface.



INFORMATIE

De buitenbestendige lampen van Monsieur Tricot (voor bestaan uit een bol in PMMA kunststof met een verwijderbare handgehaakte of gebreide hoes uit polypropyleen.

Staanlampen

- Lamp
 - dimbare LED lamp, 9-12.6 Volt, Kelvin 2.129
 - brandt gedurende 12 uur indien de dimmer op 100% staat
- Opladen
 - Herlaadbare batterij
 - Voedingsadapter met USB-aansluiting, kabel inbegrepen
 - 5 uur oplaadtijd
- Besturing
 - Aan/uit schakelaar
- Extra
 - Inclusief plafondhaak om uw staande lamp om te vormen in een hanglamp

Hanglampen

- Lamp
 - E27/E26 fitting met dimbare LED-gloeilamp inbegrepen, Kelvin 2200
 - Aansluiten op het elektriciteitsnet, 220-240 volt.
 - 5 meter kabel, montagebeugel, plafondkap en draadaansluitklemmen inbegrepen
 - Neem contact op met een plaatselijke professional om een hangende Monsieur Tricot-lamp te installeren
- Besturing
 - Gebruik een reeds beschikbare schakelaar of laat een lokale professional een nieuwe schakelaar installeren. Schakelaars kunnen niet worden gekocht bij Tribù.

Certificaten

- CE (EU + UK), RoHS 2.0 (EU), FCC (VS), IC (Canada), SAA (Australië & Nieuw-Zeeland), RCM (Australië & Nieuw-Zeeland, enkel voor staanlampen), MOC (Israël).
- IK08
- IP65

ONDERHOUD

De gehaakte hoes kan eenvoudig worden verwijderd om te worden gereinigd in de wasmachine op 40° (synthetisch wasprogramma). Laten drogen in de lucht, zeker niet in de droogkast. Trek het Lebonnet-breiwerk goed uit voordat u het te drogen legt. Hardnekkige vlekken kunnen worden verwijderd met Synthetics Super Cleaner (p. 208). Gebruik een microvezeldoekje om de lampvorm te reinigen. Gebruik geen schuurspons, dit veroorzaakt krassen en beschadigt het oppervlak.



INFORMATION

Tribù outdoor rugs are the only outdoor rugs on the market that are made of 100% solution dyed PVC coated polyester. This gives them not only an excellent UV resistance - they are also very easy to clean because the yarns do not absorb water. They dry quickly and are stain repellent. All rugs are hand woven which results in an artisanal look and makes each rug unique.

MAINTENANCE

Vacuum the rug regularly to remove loose dirt. Clean with a garden hose or even a high pressure cleaner. Stubborn stains can be removed with Synthetics Super Cleaner (p. 208). To protect the rug against stains, Synthetics Protector (p. 208) can be used which applies an invisible film.

INFORMATION

Les tapis d'extérieur de Tribù sont les seuls tapis sur le marché fabriqués par 100% en polyester enduit de PVC teinté dans la masse. Cela leur confère non seulement une excellente résistance aux UV, mais les rend très faciles à nettoyer parce que les fibres n'absorbent pas d'eau. Ils sèchent rapidement et sont antitaches. Tous les tapis sont tissés à la main, ce qui produit un aspect artisanal et rend chaque tapis unique.

ENTRETIEN

Aspirez régulièrement le tapis pour éliminer les saletés superficielles. Nettoyez avec un flexible d'arrosage ou même un nettoyeur haute pression. Les taches récalcitrantes peuvent être éliminées avec Synthetics Super Cleaner (p. 208). Pour protéger le tapis contre les taches, vous pouvez appliquer Synthetics Protector (p. 208), qui applique un film invisible antisalissures.

INFORMATIE

De buitentapijten van Tribù zijn de enige buitentapijten op de markt die 100% gemaakt zijn van polyester gecoat met in de massa gekleurde PVC. Dit geeft hen niet alleen een uitstekende UV-bestendigheid - ze zijn ook zeer gemakkelijk te reinigen omdat de vezels geen water absorberen. Ze drogen snel en zijn vlekafstotend. Alle tapijten worden met de hand geweven wat resulteert in een ambachtelijk uitzicht en elk tapijt uniek maakt.

ONDERHOUD

Stofzuig het tapijt regelmatig om los vuil te verwijderen. Reinig met een tuinslang of zelfs een hogedrukreiniger. Hardnekkige vlekken kunnen verwijderd worden met Synthetics Super Cleaner (p. 208). Om het tapijt te beschermen tegen vlekken, kan Synthetics Protector (p. 208) gebruikt worden dat een onzichtbare, vuilafstotende film aanbrengt.

POWDERCOATED STAINLESS STEEL

INOX LAQUÉ - GEPOEDERLAKT INOX

CTR, NODI, NOX, TOSCA & T-TABLE

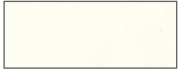

INFORMATION

Stainless steel is an iron alloy in which the resistance to corrosion is increased by the addition of chrome, molybdenum and nickel. When exposed to air, a chromium oxide skin is formed spontaneously that protects the metal against rust. By powdercoating stainless steel, you can increase its corrosion resistance to the same level as that of aluminium. For its powdercoated stainless steel furniture Tribù uses 304L stainless steel that is ceramic blasted before it is powdercoated. Tribù always uses European, ultra-durable and scratch-resistant polyester powdercoating that guarantee a UV-resistance of 15 years.



MAINTENANCE

Powdercoated stainless steel is easy to clean with clear water and a pH-neutral fluid detergent. Stubborn stains can be removed with Coated aluminium & stainless steel Cleaner (p. 206). If necessary, use a soft brush to remove the dirt from the pores. To protect the frame against the adhesion of dirt and to reduce fingerprints, Coated aluminium & stainless steel Protector (p. 206) can be used which applies an invisible protective film.

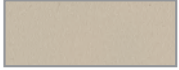

INFORMATION

L'acier inoxydable ou « inox » est un alliage de fer dont la résistance à la corrosion a été améliorée par l'adjonction de chrome, de molybdène et de nickel. En cas d'exposition à l'air, il se forme spontanément une pellicule d'oxyde de chrome qui protège contre la rouille. Le laquage par poudre de l'inox accroît sa résistance à la corrosion jusqu'au niveau de celle de l'aluminium. Pour l'acier inox revêtu de laque en poudre, Tribù utilise l'inox 304L, qui subit un grenailage céramique avant l'application du laquage en poudre. Tribù utilise toujours des laques polyester en poudre européennes ultra durables, avec une résistance aux UV de 15 ans.

ENTRETIEN

L'acier inoxydable revêtu de laque en poudre est facile à entretenir avec de l'eau pure et un détergent liquide à pH neutre. Vous pouvez éliminer les taches récalcitrantes avec de l'Coated aluminium & stainless steel Cleaner (p. 206). Si nécessaire, employez une brosse douce pour éliminer les saletés dans les pores. Pour protéger le cadre contre l'incrustation de saletés, on peut employer Coated aluminium & stainless steel Protector (p. 206), qui applique une couche de protection invisible.

INFORMATIE

Roestvast staal of inox is een ijzerlegering waarvan de corrosiebestendigheid verhoogd wordt door de toevoeging van chroom, molybdenum en nikkel. Bij blootstelling aan lucht wordt spontaan een chroomoxidehuid gevormd, die tegen roest beschermt. Door inox te poederlakken wordt de corrosiebestendigheid tot het niveau van dat van aluminium verhoogd. Voor gepoederlakt roestvast staal gebruikt Tribù 304L inox, dat keramisch gepareelstraald wordt vóór het poederlakken. Tribù gebruikt steeds ultra-durable Europese krasbestendige polyesterpoederlakken met een UV-bestendigheid van 15 jaar.

ONDERHOUD

Gepoederlakt roestvast staal is makkelijk te onderhouden met zuiver water en een pH-neutraal, vloeibaar detergent. Hardnekkige vlekken kan u verwijderen met Coated aluminium & stainless steel Cleaner (p. 206). Gebruik indien nodig een zachte borstel om vuil uit de poriën te verwijderen. Om het frame te beschermen tegen vasthechten van vuil, kan Coated aluminium & stainless steel Protector (p. 206) gebruikt worden dat een onzichtbare beschermlaag aanbrengt.

GOBI



INFORMATION

Illia Eckhard's goal was to uncover the true essence of the basket. He created Gobi after conducting an in-depth study of skill and artisanship, which we believe are the most authentic expressions of people's humanity and creativity. The beauty of the Gobi basket makes it a stellar example of Belgian dexterity and artisanship. Each one is made by skilled artisans using traditional weaving techniques.

The ropes are made from recycled plastic bottles, with an outer layer of recycled acrylic. The result is a unique product every time, with slight differences in colour and shape.

To maintain the original look and feel of your Gobi baskets, we recommend not leaving them out in the rain, as they take a long time to dry out. If your baskets do get wet, it's best to leave them to dry out fully in the open air, allowing all the moisture to evaporate. We have decided not to produce protective covers, as we believe it's better to bring the baskets indoors when it rains.

MAINTENANCE

Our synthetic furniture pieces are easy to maintain with clear water and a pH neutral soap. Stubborn stains can be removed with Synthetics Super Cleaner (p. 208). If necessary, use a soft brush to remove dirt from the pores. For extra protection we recommend Synthetics Protector (p. 208) which apply an invisible film and reduces the adhesion of dirt.

INFORMATION

Illia Eckhard s'est efforcé de retrouver l'essence du panier. Au terme d'une recherche esthétique autour du travail manuel et de l'artisanat, il a créé Gobi. Nous croyons qu'il représente l'expression la plus authentique de l'humanité et de la créativité. Le savoir-faire manuel et l'artisanat belges sont incarnés dans la beauté de ce produit. Chaque panier GOBI a été confectionné par un maître-artisan mettant en œuvre des techniques de vannerie traditionnelles.

La couche externe des cordes est en acrylique recyclé tandis que leur âme est fabriquée à partir de bouteilles en plastique recyclées. Chaque article est unique car il varie légèrement en termes de couleur et de forme.

Pour que les paniers Gobi conservent leur look-and-feel, nous vous recommandons de ne pas les laisser dehors sous la pluie. S'ils sont mouillés, il leur faut longtemps pour sécher. Il est recommandé de les laisser sécher complètement à l'air libre. Nous avons décidé de ne pas proposer de protections car nous pensons qu'il vaut mieux les rentrer en cas de pluie.

ENTRETIEN

Le synthétique s'entretient aisément avec de l'eau pure et un détergent liquide à pH neutre. Les taches récalcitrantes peuvent être éliminées avec le Synthetic Super Cleaner (p. 208). Si nécessaire, employez une brosse douce pour éliminer les saletés dans les pores. Pour une protection supplémentaire, nous recommandons du Synthetics Protector (p. 208) qui appliquent un film invisible réduisant l'incrustation de saletés.

INFORMATIE

Illia Eckhard ging op zoek naar de ware essentie van de mand. Hij creëerde Gobi na een diepgaande studie van handwerk en vakmanschap, volgens ons de meest authentieke uiting van menselijkheid en creativiteit. De schoonheid van de Gobi-mand is een prachtig voorbeeld van Belgische technische vaardigheid en vakmanschap. Elk exemplaar is gemaakt door bekwame ambachtslieden met traditionele weeftechnieken.

De touwen zijn gemaakt van gerecycleerde petflessen, met een buitenlaag van gerecycleerd acryl. Het resultaat is telkens een uniek product, met kleine verschillen in kleur en vorm.

Om de originele look en feel van uw Gobi-manden te behouden, raden we u aan ze niet in de regen te laten staan, want het duurt lang voor ze drogen. Als uw manden nat worden, kunt u ze het best in de open lucht volledig laten drogen, zodat al het vocht kan verdampen. We hebben ervoor gekozen geen covers te maken omdat we het beter vinden dat u de manden binnen zet als het regent.

ONDERHOUD

Kunststof is eenvoudig te reinigen met zuiver water en een pH neutraal detergent. Hardnekkige vlekken kunnen verwijderd worden met Synthetics Super Cleaner (p. 208). Gebruik indien nodig een zachte borstel om vuil uit de poriën te verwijderen. Voor extra bescherming raden we Synthetics Protector (p. 208) aan die een onzichtbare film aanbrengen die de aanhechting van vuil vermindert.

**INFORMATION**

Tribù only uses high grade virgin polypropylene compound for the production of the Vintage and Branch collection. The mass dyed PP is made anti-static, anti-fungal, frost resistant and stain repellent by the addition of additives. Also, contact with salt or chlorine water causes no problems. A very high percentage of UV stabilizing additives guarantees extremely high colour fastness, even after a long exposure to sunlight. Sharp objects should be avoided as they may cause scratches.

MAINTENANCE

Our synthetic furniture pieces are easy to maintain with clear water and a pH neutral soap. Stubborn stains can be removed with Synthetics Super Cleaner (p. 208). If necessary, use a soft brush to remove dirt from the pores. For extra protection we recommend Synthetics Protector (p. 208) or Coated aluminium & stainless steel Protector (p. 206) which apply an invisible film and reduces the adhesion of dirt.

INFORMATION

Pour les collections contenant des matières synthétiques, Tribù emploie exclusivement des composants de haute qualité avec polypropylène pur. Le PP teinté dans la masse est rendu antistatique, antimoisissures, résistant au gel et aux taches par l'adjonction d'additifs. Le contact avec l'eau saline ou chlorée ne provoque pas de problèmes non plus. Un pourcentage très élevé d'additifs de stabilisation UV garantit une tenue très élevée des couleurs, même après une longue exposition au soleil. Il faut éviter les objets tranchants, qui risquent provoquer des rayures.

ENTRETIEN

Le synthétique s'entretient aisément avec de l'eau pure et un détergent liquide à pH neutre. Les taches récalcitrantes peuvent être éliminées avec le Synthetic Super Cleaner (p. 208). Si nécessaire, employez une brosse douce pour éliminer les saletés dans les pores. Pour une protection supplémentaire, nous recommandons du Synthetics Protector (p. 208) ou Coated aluminium & stainless steel Protector (p. 206), qui appliquent un film invisible réduisant l'incrustation de saletés.

INFORMATIE

Tribù gebruikt enkel hoogwaardige, zuivere polypropyleen samenstellingen voor de collecties die kunststof bevatten. De in de massa gekleurde PP is anti-statisch, anti-schimmel, vorst- en vlekbestendig gemaakt door de toevoeging van additieven. Ook contact met zout of chloor water veroorzaakt geen problemen. Een zeer hoog percentage UV-stabiliserende additieven garandeert een extreem hoge kleurvastheid, zelfs na een lange blootstelling aan zonlicht. Scherpe voorwerpen dienen vermeden te worden aangezien ze krassen kunnen veroorzaken.

ONDERHOUD

Kunststof is eenvoudig te reinigen met zuiver water en een pH neutraal detergent. Hardnekkige vlekken kunnen verwijderd worden met Synthetics Super Cleaner (p. 208). Gebruik indien nodig een zachte borstel om vuil uit de poriën te verwijderen. Voor extra bescherming raden we Synthetics Protector (p. 208) of Coated aluminium & stainless steel Protector (p. 206) aan die een onzichtbare film aanbrengen die de aanhechting van vuil vermindert.

AMANU, DUNES, ELIO, HEXAGON, ILLUM, KOS, MOOD, NOMAD, PAVILION, PURE SOFA, ROOTS, SENJA, OTTO, TAIRU, T-TABLE, UKIYO & VIS À VIS



INFORMATION

Because Tribù makes no concessions when it comes to quality, we only use carefully selected, fully grown teak, which is harvested in accordance with the strictest environmental standards from the three highest quality Indonesian plantations in the East of Java. The local productions are checked all year round by subsidiary Tribù Asia, based in Semarang and led by a European management. Tribù designs its furniture in the way that the wood is used as efficiently as possible.

Teak is classed as the most premium wood on the planet and therefore the most suitable species for outdoor furniture. Beyond its beauty, teak possesses some natural properties that other woods don't have. It is extremely durable, stable, water and weather resistant. This is due to the high levels of natural oils which result in minimal moisture absorption, giving it great stability. Moreover, the wood is extremely resistant to fungi, as well as against parasite attacks and insects.

A tree is mature after 75 to 80 years. The trees are ringed, which means that the lower band of the bark is removed. The tree then loses most of its sap. About two years later it is felled and sawed up. Tribù selects each log based on its structure. Drying the wood is a very important phase and determines how it reacts later on. The time and speed of drying depends on the thickness of the material. Ideally the level of moisture lies between 8 and 12%.

MAINTENANCE

Teak left in its natural state, is virtually maintenance-free. It can be left outside all year round, surviving even the most extreme weather conditions. New teak will experience natural oil surfacing that appears like a "watermark" or irregular pattern of discoloration. These areas are part of the natural maturing process and can be removed with gentle washing with Teak Super Cleaner (p. 204).

Over time, untreated teak furniture which is exposed to sun and rain will turn silver grey. This process is cosmetic and does not harm the strength or quality of the wood.

To avoid the annual cleaning of the wood, you can apply Teak Sealer (p. 204). Teak Sealer contains UV protection to slow down the graying from the sun as well as a fungicide to prevent the growth of mold and mildew. Teak Sealer can be applied to new teak or old teak furniture after it has been cleaned. We recommend using Teak Super Cleaner (p. 204) to clean soiled furniture. If Teak Sealer is applied every season, a simple cleaning with water and a pH neutral soap will do for years. Teak Sealer is a sealer and is not the same as varnish. It is breathable, letting the natural oils escape without bubbling or peeling like varnish.

Teak Protector (p. 205) protects the wood against stains and green deposit, without colouring the wood. We recommend to apply it after each cleaning.

USE OF VARNISH AND OIL ON TEAK

Teak is protected by its own natural oils that migrate to the surface of the wood and make the wood virtually impervious to water. As such, the use of varnish and oil (especially linseed oil) on teak furniture is not recommended. Products such as varnish and polyurethane may peel and chip and require vigorous sanding to remove. Oiling teak does not prevent the wood from graying, and often results in mold and mildew growing on the furniture. Removing mold and mildew on the surface requires washing the furniture with bleach and soap followed by sanding. Tribù and authorities from the timber profession itself tend to advise against the use of teak oil.

OIL STAINS ON CUSHIONS

Because teak does not absorb water and is rich in natural oils and silicates, the weathering process includes oil surfacing. This teak oil can cause stains on cushions. Fabric stained by natural teak oil can be cleaned with soap and water or a special eucalyptus-based cleaner. Please be aware oil surfacing is a naturally repeating process that cannot be prevented.

AMANU, DUNES, ELIO, HEXAGON, ILLUM, KOS, MOOD, NOMAD, PAVILION, PURE SOFA, ROOTS, SENJA, OTTO, TAIRU, T-TABLE, UKIYO & VIS À VIS



INFORMATION

Comme Tribù ne fait aucune concession à la qualité, nous utilisons exclusivement des arbres adultes soigneusement sélectionnés, qui sont récoltés dans le respect des normes environnementales les plus strictes dans les trois plantations les plus qualitatives de l'est de Java. Les productions locales sont contrôlées pendant toute l'année par notre filiale Tribù Asia, établie à Semarang et dirigée par un management européen. Tribù conçoit ses meubles de façon à ce que le bois soit utilisé de la manière la plus efficace possible et qu'il y ait un minimum de déchets.

Le teck est considéré comme l'espèce de bois possédant la plus haute qualité au monde et constitue donc l'essence la plus appropriée pour le mobilier de jardin. Outre sa beauté, le teck possède une série de propriétés naturelles que ne possèdent pas les autres essences. Il est extrêmement durable, stable, et résiste à l'eau et aux intempéries. Cela s'explique par sa concentration élevée en huiles naturelles, qui résulte en une absorption minimale d'humidité et qui confère au bois une stabilité importante. En outre, le teck est extrêmement résistant aux champignons et insensible aux parasites et insectes.

Un arbre est adulte après 75 à 80 ans. Les arbres sont annelés, c.-à-d. que la partie inférieure de l'écorce est enlevée. L'arbre perd alors la plus grande partie de sa sève. Environ deux ans plus tard, l'arbre est abattu et débité. Tribù sélectionne chaque lot selon la structure de chaque dosse. Le séchage du bois constitue une phase très importante et détermine le comportement ultérieur du bois. La vitesse de séchage dépend de l'épaisseur du matériau. Le niveau idéal de l'hygrométrie se situe entre 8 et 12 %.

ENTRETIEN

Le teck est une essence unique qui n'exige pratiquement pas d'entretien dans son état naturel. Les meubles en teck peuvent rester au grand air pendant toute l'année, même dans les intempéries les plus extrêmes. Chez le teck neuf, un « filigrane » ou motif de décoloration irrégulière peut apparaître en raison de la migration de l'huile naturelle vers la surface. Cela fait partie du processus de vieillissement naturel, et peut être éliminé par un nettoyage doux au Teak Super Cleaner (p. 204).

Après un certain temps, le teck non traité prendra une teinte gris argent en raison de son exposition au soleil et à la pluie. Il s'agit d'un processus esthétique qui n'a aucune influence sur la résistance ou la qualité du bois. Afin d'éviter le nettoyage annuel du teck, vous pouvez appliquer du Teak Sealer (p. 204). Ce produit contient une protection UV pour ralentir le grisonnement par le soleil, ainsi qu'un fongicide pour empêcher la prolifération de moisissures et de mildiou. Teak Sealer peut être utilisé pour un mobilier en teck neuf ou ancien après que celui-ci ait été nettoyé. Nous recommandons d'utiliser Teak Super Cleaner (p. 204) en cas de mobilier encrassé. Si vous appliquez le Teak Sealer chaque saison, un simple nettoyage avec de l'eau et un savon au pH neutre suffira pendant des années. Le Teak Sealer est un scellant, ce qui n'est pas la même chose qu'un vernis. Il est respirant, ce qui permet aux huiles naturelles de s'évaporer sans formation de cloques ou d'écaillage.

Le Teak Protector (p. 205) protège le bois contre les taches et les dépôts verts, sans teindre le bois; il est conseillé de l'appliquer après chaque nettoyage.

UTILISATION DE VERNIS ET D'HUILE SUR LE TECK

Le teck est protégé par ses propres huiles naturelles qui migrent vers la surface du bois et qui le rendent étanche. L'utilisation de vernis et d'huile (surtout l'huile de lin) sur le teck est déconseillée. Les produits comme le vernis ou le polyuréthane peuvent s'écailler et peuvent être éliminés uniquement par un ponçage énergique. Huiler le teck n'empêche pas le bois de griser et provoque souvent des moisissures et l'apparition de mildiou. Ils peuvent être éliminés avec un blanchiment et du savon, suivis par un ponçage. Tribù et l'industrie du bois conseillent de ne pas utiliser d'huile sur le teck.

TACHES DE TECK SUR LES COUSSINS

Comme le teck n'absorbe pas d'eau et est riche en huiles naturelles et en silicates, l'huile finit toujours par remonter spontanément. Cette huile peut provoquer des taches sur les coussins, qui peuvent être éliminées avec de l'eau et du savon ou un nettoyant spécial à base d'eucalyptus. Il faut tenir compte du fait que la remontée d'huile est un phénomène naturel et répétitif qu'il n'est pas possible de prévenir.

AMANU, DUNES, ELIO, HEXAGON, ILLUM, KOS, MOOD, NOMAD, PAVILION, PURE SOFA, ROOTS, SENJA, OTTO, TAIRU, T-TABLE, UKIYO & VIS À VIS



INFORMATIE

Omdat Tribù geen toegevingen doet als het gaat over kwaliteit, worden enkel zorgvuldig geselecteerde, volgroeide teakbomen gebruikt, die met respect voor de strengste milieunormen geoogst worden uit de drie meest kwalitatieve plantages uit Oost-Java. De plaatselijke producties worden het hele jaar door gecontroleerd door dochterfirma Tribù Asia, gevestigd in Semarang en geleid door een Europees management. Tribù ontwerpt zijn meubels op die manier dat het hout zo efficiënt mogelijk gebruikt wordt en er zo weinig mogelijk afval is.

Teak wordt geclassificeerd als de meest superieure houtsoort ter wereld en is daarom de meest geschikte soort voor buitenmeubilair. Naast zijn schoonheid, beschikt teak over een aantal natuurlijke eigenschappen die andere houtsoorten niet hebben. Het is uiterst duurzaam, stabiel en water- en weerbestendig. Dit komt door het hoge niveau van natuurlijke oliën wat resulteert in een minimale vochtabsorptie, waardoor het hout een grote stabiliteit krijgt. Bovendien is teakhout extreem schimmelbestendig, alsook bestand tegen parasieten en insecten.

Een boom is volgroeid na 75 tot 80 jaar. De bomen worden geringd, dit wil zeggen dat de onderste laag van de bast verwijderd wordt. De boom verliest dan het meeste van zijn sap. Ongeveer twee jaar later wordt de boom gekapt en verzaagd. Tribù selecteert elk lot stuk per stuk op zijn structuur. Het drogen van het hout is een zeer belangrijke fase en bepaalt hoe het later zal reageren. De snelheid van het drogen hangt af van de dikte van het materiaal. Het ideale niveau van het vochtgehalte ligt tussen 8 en 12%.

ONDERHOUD

Teak is een unieke houtsoort die in zijn natuurlijke toestand vrijwel geen onderhoud vraagt. Teakmeubelen kunnen heel het jaar door buiten blijven, zelfs in de meest extreme weeromstandigheden. Bij nieuwe teak kan een 'watermerk' of een onregelmatig patroon van verkleuring verschijnen door de natuurlijke olie die naar boven komt. Dit maakt deel uit van het natuurlijke rijpingsproces en kan verwijderd worden met een zachte reiniging met Teak Super Cleaner (p. 204).

Na verloop van tijd zal onbehandeld teak door blootstelling aan zon en regen zilvergrijs kleuren. Dit is een esthetisch proces en heeft geen invloed op de sterkte of kwaliteit van het hout. Om de jaarlijkse reiniging met Teak Cleaner te vermijden, kan u het teak met Teak Sealer (p. 204) behandelen. Teak Sealer bevat UV bescherming om vergrijzing door de zon te vertragen, alsook een fungicide om de groei van schimmel en meeldauw te voorkomen. Teak Sealer kan gebruikt worden voor nieuw of oud teak meubilair nadat het gereinigd is. Wij raden aan om Teak Super Cleaner (p. 204) te gebruiken bij vervuild meubilair. Als u Teak Sealer 1x per seizoen aanbrengt, volstaat gedurende jaren een eenvoudige reiniging met water en een neutrale zeep. Teak Sealer is een sealer en is niet hetzelfde als vernis. Het is ademend, waardoor de natuurlijke oliën kunnen ontsnappen zonder bubbelvorming of afbladderend.

Teak Protector (p. 205) beschermt het hout tegen vlekken en groenaanslag, zonder het hout te kleuren en brengt u best na elke reiniging aan.

GEBRUIK VAN VERNIS EN OLIE OP TEAK

Teak wordt beschermd door zijn eigen natuurlijke oliën die migreren naar het oppervlak van het hout en die het hout waterdicht maken. Het gebruik van vernis en olie (vooral lijnzaadolie) op teak worden afgeraden. Producten zoals vernis en polyurethaan kunnen afbladderen en kunnen enkel verwijderd worden door krachtig schuren. Teak oliën voorkomen niet dat het hout gaat vergrijzen en veroorzaakt vaak schimmel en groei van meeldauw. Deze kunnen verwijderd worden met bleekmiddel en zeep, gevolgd door schuren. Tribù en de houtindustrie adviseren om geen olie te gebruiken op teak.

TEAKVLEKKEN OP KUSSENS

Omdat teak geen water absorbeert en rijk is aan natuurlijke oliën en silicaten, komt die natuurlijke olie met de tijd spontaan naar boven. Deze olie kan vlekken op kussens veroorzaken die verwijderd kunnen worden met zeep en water of een speciaal reinigingsmiddel op basis van eucalyptus. Gelieve in acht te nemen dat het aan de oppervlakte komen van olie een natuurlijk, herhalend proces is, dat niet kan voorkomen worden.

TEXTILENE STRAPS

BANDES TEXTILENE - TEXTILEEN BANDEN

NATAL ALU SOFA



INFORMATION

The textile straps of the Natal Alu Sofa consist of a coated polyester weave. The combination of PVC and polyester guarantees a lasting high tension and provides an excellent resistance to all weather conditions. The straps dry quickly and are stain repellent. A fungi-repellent treatment prevents the formation of mold.

MAINTENANCE

The textile straps are easy to clean with clear water and a pH-neutral soap. Stubborn stains can be removed with Synthetics Super Cleaner (p. 208). If necessary, use a soft brush to remove dirt between the straps. Do not use acid, alkaline or chlorinated products that can harm the hardware of your furniture.

For extra protection we recommend Synthetics Protector (p. 208) which applies an invisible film and reduces the adhesion of dirt.

INFORMATION

Les bandes en textilène du Natal Alu Sofa sont constituées d'un tissage en polyester couché, tout comme les Batyline. La composition du matériau garantit une tension prolongée et élevée de l'assise, ainsi qu'une excellente résistance aux intempéries. Les bandes ne se décolorent pas, sont insensibles aux taches et sèchent rapidement. Un traitement antimoisissures prévient la prolifération de moisissures par l'humidité.

ENTRETIEN

Les bandes textilène peuvent être nettoyées simplement avec de l'eau pure et un détergent liquide à pH neutre. Pour les taches récalcitrantes, vous pouvez utiliser Synthetics Super Cleaner (p. 208). Utilisez une brosse douce pour éliminer les saletés entre le tissage. N'employez pas de sel ou de produits contenant du chlore, car ceux-ci pourraient attaquer la carcasse du meuble.

Pour une protection supplémentaire, nous recommandons du Synthetics Protector (p. 208) qui applique un film invisible réduisant l'incrustation de saletés.

INFORMATIE

De textieleen banden van de Natal Alu Sofa bestaan uit een weving van gecoat polyester, net als de Batylines. De samenstelling van het materiaal garandeert een langdurige en hoge spanning van de zitting en een uitstekende weerbestendigheid. De banden verkleuren niet, zijn vlekwerend en drogen snel. Een schimmelwerende behandeling voorkomt het ontstaan van schimmel door vocht.

ONDERHOUD

De textieleen banden zijn eenvoudig te reinigen met zuiver water en een pH-neutraal, vloeibaar detergent. Voor hardnekkige vlekken kan u Synthetics Super Cleaner (p. 208) gebruiken. Met een zachte borstel kan u vuil tussen de banden verwijderen. Gebruik geen zout of chloorhoudende producten omdat die de hardware van het meubel zou kunnen aantasten.

Voor extra bescherming raden we Synthetics Protector (p. 208) aan die een onzichtbare film aanbrengt die de aanhechting van vuil vermindert.

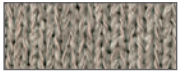

INFORMATION

The extra-large weave that is used for the Tosca collection is made with a material that was developed exclusively by Tribù. A great deal of research went into the material, resulting in a unique product with a natural and soft appearance, that is nevertheless 100% weatherproof. An EPDM foam filling is over braided with a tubular, seamless cover of knitted textile and Tricord (polyolefin). The material is fungi-resistant, stain-repellent, does not fade and dries relatively quickly. It is 100% suitable for outdoor use in any environment. However, to minimize cleaning, we advise to use our covers when not using the furniture.

MAINTENANCE

Rinse the braiding regularly with clean water. For intensive cleaning, use Synthetics Super Cleaner (p. 208). This cleaner also works perfectly for the powdercoated stainless steel frame. Always rinse the furniture with clean water after treatment with cleaning agents. Allow the braid to dry and treat with Textile Protector (p. 209). This will apply an invisible stain repellent film which enables the furniture to dry quicker. The cleaning will also become easier, less frequent and requires mainly rinsing with clean water.

INFORMATION

Le tissage extralarge employé pour la collection Tosca est une exclusivité mise au point par Tribù. Il a fallu de longues recherches pour trouver un matériau à l'aspect doux et naturel, mais cependant 100 % résistant aux intempéries. Une housse sans coutures en textile et Tricord (polyoléfine) est tricotée autour d'un garnissage en mousse EPDM. Le matériau résiste aux moisissures, aux taches et aux UV, et sèche relativement vite. Il convient pour être utilisé au grand air dans n'importe quel environnement. Pour limiter au maximum le nettoyage, nous conseillons de protéger les meubles avec des housses lorsque vous ne les utilisez pas.

ENTRETIEN

Nettoyez régulièrement le tissage avec de l'eau pure. Les taches récalcitrantes peuvent être éliminées avec le Synthetics Super Cleaner (p. 208). Ce produit peut être utilisé également pour nettoyer le cadre en inox revêtu de laque en poudre. Rincez toujours bien les meubles à l'eau pure. Après nettoyage avec des produits de nettoyage laissez bien sécher le tissage et traitez-le ensuite avec Textile Protector (p. 209), qui le rend résistant aux taches et lui permet de sécher plus rapidement. Le nettoyage deviendra ainsi plus facile et pourra être effectué moins fréquemment.

INFORMATIE

De extra brede weving die gebruikt wordt voor de Tosca collectie werd exclusief door Tribù ontwikkeld. Er ging veel research aan vooraf om te komen tot een materiaal dat er zacht en natuurlijk uitziet, maar toch 100% weerbestendig is. Rond een EPDM schuimvulling wordt een naadloze hoos van textieleen en Tricord (polyolefine) gebreid. Het materiaal is schimmel-, vlek- en UV bestendig en droogt relatief snel. Het is geschikt voor buitengebruik in elke omgeving. Om reinigen tot een minimum te beperken, raden we wel aan de meubelen te bedekken met beschermhoezen als u ze niet gebruikt.

ONDERHOUD

Reinig de weving regelmatig met zuiver water. Hardnekkige vlekken kunnen verwijderd worden met Synthetics Super Cleaner (p. 208). Dit product kan ook gebruikt worden om het gepoederlakte rvs frame te reinigen. Spoel de meubelen altijd goed na met zuiver water. Laat de weving goed drogen en behandel daarna met Textile Protector (p. 209) die vlekwerend werkt en ervoor zorgt dat de weving sneller droogt. Het reinigen zal hierdoor makkelijker worden en minder frequent nodig zijn.



INFORMATION

Travertine, a captivating natural stone, boasts unique characteristics and extensive applications. Formed by mineral deposits in natural springs, it features a distinctive porous texture that lends an elegant and rustic charm to both indoor and outdoor spaces. Its soft, neutral tones range from warm beige to cool gray, ensuring that every top is unique.

This originality is intensified by the stain-sensitive nature of the material. Oil, red wine, as well as other liquids and acids are absorbed, resulting in a permanent stain. This makes it a 'living thing' that, in time, displays subtle changes in colour and even surface structure. A product that becomes more and more unique with use, perfect for people who appreciate a table with personality.

MAINTENANCE

For daily cleaning, rub with a soft clean cloth immersed in a solution of hot, pure water and a pH-neutral detergent. Rinse thoroughly and leave to dry. Spills should be wiped up immediately, particularly acids, which can stain. Bird droppings and leaves can also stain if not removed immediately. We advise you to cover your table with a protective cover when not in use.

INFORMATION

Le travertin, une pierre naturelle captivante, possède des caractéristiques uniques et de nombreuses applications. Formé par les dépôts minéraux des sources naturelles, il présente une texture poreuse distincte qui confère un charme élégant et rustique aux espaces intérieurs et extérieurs. Ses tons doux et neutres se déclinent du beige chaud au gris froid, ce qui fait de chaque surface un objet unique.

Cette originalité est renforcée par la sensibilité du matériau aux taches. Il absorbe l'huile, le vin rouge, ainsi que d'autres liquides et acides pour créer une tache indélébile. Il est donc « vivant » et sa surface présente, avec le temps, de subtils changements de couleur et même de structure pour former un produit dont le caractère unique s'affirme au fil des utilisations. Il est donc parfait pour les personnes qui aiment une table avec de la personnalité.

ENTRETIEN

Pour le nettoyage quotidien, frottez le produit avec un chiffon doux et propre plongé au préalable dans une solution d'eau chaude et d'un détergent au pH neutre. Rincez abondamment et laissez sécher. Les liquides renversés doivent être essuyés immédiatement, en particulier les acides, qui peuvent laisser des taches. Les fientes d'oiseaux et les feuilles peuvent également provoquer des taches si elles ne sont pas essuyées immédiatement. Nous vous recommandons d'utiliser une housse de protection lorsque vous n'utilisez pas votre table.

INFORMATIE

Travertine ziet er uniek uit en kan voor talrijke zaken worden aangewend. Deze steensoort wordt gevormd door natuurlijke minerale afzettingen en heeft een kenmerkende poreuze textuur die zowel binnen als buiten een elegante en rustieke charme uitstraalt. De zachte, neutrale tinten van warmbeige tot koel grijs garanderen een uniek tafelblad.

Het bijzondere karakter wordt versterkt door de vlekgevoeligheid van het materiaal. Olie, rode wijn, maar ook andere vloeistoffen en zuren worden geabsorbeerd, waardoor een permanente vlek ontstaat. Het product is gemaakt van een 'levend materiaal' dat na verloop van tijd subtiele veranderingen in kleur en zelfs oppervlaktestructuur vertoont. Een product dat met gebruik zijn eigen karakter verder ontwikkelt, speciaal voor mensen die een tafel met persoonlijkheid waarderen.

ONDERHOUD

Dompel voor dagelijkse reiniging een zachte, propere doek onder in een oplossing van warm, zuiver water en een pH-neutraal vloeibaar reinigingsmiddel. Spoel grondig af en laat drogen. Vlekken dienen onmiddellijk te worden afgeveegd, vooral zure stoffen daar ze permanente vlekken kunnen veroorzaken. Ook vogeluitwerpselen en bladeren kunnen permanente vlekken veroorzaken als ze niet onmiddellijk worden verwijderd. We raden u aan een beschermhoes te gebruiken als u uw tafel niet gebruikt.



INFORMATION

Tricord® is a brand new composite material for which Tribù has exclusivity. It is a unique combination of nautical and synthetic fibres. The inside consists of unbreakable polyester that gives it strength and stability. The outside is a combination of nautical fibres that create a surprisingly soft touch and natural appearance. The composition of these nautical fibres (polyofin) makes Tricord® completely resistant to outside influences: frost, water, fungi and UV-rays.

The furniture is hand woven - no two pieces are ever alike. The unique craft appearance is part and parcel of the charm of the product and cannot be regarded as a fault. The backs of the Mood and CTR collection can be purchased individually and easily replaced if necessary.

MAINTENANCE

Before use, we recommend to treat the Tricord® weave with Textile Protector (p. 209) which applies an invisible, dirt and water repellent film. The straps can be cleaned with clear water and a ph-neutral detergent or Synthetics Super Cleaner (p. 208). Allow the detergent to act for a while, then rinse abundantly with clean water. Drying may take a while on cloudy days.

After cleaning, treat with Textile Protector (p. 209). The cleaning will become easier and will require mainly rinsing with clean water.

INFORMATION

Tricord® est un matériau composite tout à fait nouveau, spécialement mis au point pour Tribù. Il s'agit d'une combinaison unique de fibres nautiques et de synthétique. L'intérieur est constitué de fibres polyester incassables qui assurent résistance et stabilité. L'extérieur est une combinaison de fibres nautiques qui confèrent au matériau un toucher et une apparence naturels. La composition de ces fibres nautiques (polyoléfine) fait que Tricord® est totalement résistant au grand air: résistant au gel, à l'eau, aux moisissures et aux UV. Les meubles sont tissés à la main, il n'y a pas deux pièces identiques. L'aspect artisanal unique ainsi conféré au produit, fait partie de son charme et ne peut être considéré comme un défaut. Les dossiers des collections Mood et CTR peuvent être obtenus séparément et peuvent être remplacés facilement en cas de besoin.

ENTRETIEN

Avant l'emploi, nous recommandons de vaporiser les bandes Tricord® avec Textile Protector (p. 209), qui crée un film invisible résistant aux taches et hydrofuge. Les bandes peuvent être nettoyées avec de l'eau pure et un détergent liquide à pH neutre ou Synthetics Super Cleaner (p. 208). Il est recommandé de laisser agir un peu le détergent. Rincez abondamment avec de l'eau. Le séchage peut prendre un certain temps pendant les journées sans soleil.

Après nettoyage traitez les bandes avec Textile Protector (p. 209), le nettoyage deviendra ainsi plus facile et devra être effectué moins fréquemment.

INFORMATIE

Tricord® is een gloednieuw composietmateriaal speciaal ontwikkeld voor Tribù. Het is een unieke combinatie van nautische vezels en kunststof. De binnenzijde bestaat uit onbreekbare polyestervezels die voor sterkte en stabiliteit zorgen. De buitenzijde is een combinatie van nautische vezels die het materiaal een natuurlijk gevoel en uitstraling geven. De samenstelling van deze nautische vezels (polyofine) zorgt ervoor dat Tricord® volledig buitenbestendig is: vorst-, water-, schimmel- en UV-bestendig. De meubels worden met de hand geweven, geen enkel stuk is hetzelfde. Het unieke, artisanale uitzicht dat hieruit ontstaat, maakt deel uit van de charme van het product en kan niet gezien worden als een fout. De ruggen van de Mood en CTR collectie kunnen apart verkregen worden en zijn makkelijk te vervangen indien nodig.

ONDERHOUD

Vóór gebruik raden we aan de Tricord® weving in te spuiten met Textile Protector (p. 209) dat een zichtbare film legt die vlekbestendig en waterafstotend werkt. Reinigen kan met zuiver water en een pH-neutraal, vloeibaar detergent of Synthetics Super Cleaner (p. 208). Het detergent best even laten inwerken. Overvloedig spoelen met water. Het drogen kan een tijdje duren op niet-zonnige dagen.

Behandel daarna met Textile Protector (p. 209) dat vlekwerend werkt en ervoor zorgt dat de weving sneller droogt. Het reinigen zal hierdoor makkelijker worden en minder frequent nodig zijn.



INFORMATION

Vilex material is composed of solution-dyed PVC-coated polyester. This characteristic not only grants Vilex products outstanding UV resistance but also imparts effortless cleanability due to the non-absorbent nature of the yarns. These yarns facilitate rapid drying and exhibit stain-repelling qualities. Every item crafted from Vilex undergoes a manual weaving process, contributing to an artisanal aesthetic and ensuring the distinctiveness of each product.

MAINTENANCE

Vacuum the material regularly to remove loose dirt. Clean with a garden hose and remove stubborn stains with Synthetics Super Cleaner (p. 208). To protect against stains, Synthetics Protector (p. 208) can be used which applies an invisible film.

INFORMATION

Le matériau Vilex est composé de polyester enduit de PVC teinté dans la masse. Cette caractéristique confère aux produits Vilex une résistance exceptionnelle aux UV, ainsi qu'une facilité de nettoyage grâce à la nature non absorbante des fils. Ces fils permettent un séchage rapide et présentent des qualités anti-taches. Chaque article confectionné en Vilex est soumis à un processus de tissage manuel, ce qui lui confère une esthétique artisanale et garantit le caractère distinctif de chacun des produits.

ENTRETIEN

Passez régulièrement l'aspirateur sur le matériau pour enlever les saletés qui s'y sont déposées. Pour le nettoyage, utilisez un tuyau d'arrosage et éliminez les taches tenaces avec Synthetics Super Cleaner (p. 208). Pour protéger le produit contre les taches, utilisez le Synthetics Protector (p.208) qui laisse un film invisible

INFORMATIE

Vilex is gemaakt van in de massa geverfd pvc-gecoat polyester. Hierdoor hebben ze een uitstekende uv-bestendigheid en zijn ze niet-absorberend waardoor ze gemakkelijk schoon te maken zijn. Vilex droogt snel en is vlekafstotend. Elk Vilex-product wordt met de hand geweven, wat bijdraagt tot de ambachtelijke uitstraling die uniek is voor elk product.

ONDERHOUD

Stofzuig het product regelmatig om los vuil te verwijderen. Reinig met een tuinslang of zelfs een hogedrukreiniger. Hardnekkige vlekken kunnen verwijderd worden met Synthetics Super Cleaner (p. 208). Om het tapijt te beschermen tegen vlekken, kan Synthetics Protector (p. 208) gebruikt worden dat een onzichtbare, vuilafstotende film aanbrengt.

**INFORMATION**

Trizo, made from HDPE material, is a sturdy water- and mold-resistant material suitable for various environments. This material is colorfast and mass-colored, making it perfect for outdoor use.

**MAINTENANCE**

Trizo is easy to maintain. To remove stains, use warm, clean water and a pH neutral liquid cleaner or Synthetics Super Cleaner (p. 208). Gently buffing can help with minor scratches, so be sure not to use harsh abrasives. Using a cover can provide extra protection for the material and reduce the number of necessary maintenance sessions. For additional protection, we recommend the Synthetic Protector (p. 208), which forms an invisible layer that repels dirt.

INFORMATION

Fabriqué à partir de PEHD, Trizo est un matériau robuste, résistant à l'eau et à la moisissure, qui convient à divers environnements. Ce matériau est inaltérable et coloré dans la masse, idéal pour une utilisation en extérieur.

ENTRETIEN

Trizo est facile à entretenir. Pour enlever les taches, utilisez de l'eau chaude et propre et un détergent liquide au pH neutre ou notre Synthetics Super Cleaner (p. 208). Un léger lustrage peut aider à gommer les petites rayures, mais veillez à ne pas utiliser d'abrasifs trop agressifs. L'utilisation d'une housse offre une protection supplémentaire au matériau et permet de réduire le besoin d'entretien. Pour une protection supplémentaire, nous recommandons le Synthetic Protector (p. 208), qui laisse un film protecteur pour repousser la saleté.

INFORMATIE

Trizo, gemaakt van HDPE-materiaal, is een stevig water- en schimmelbestendig materiaal dat geschikt is voor diverse omgevingen. Dit materiaal is in de massa gekleurd voor levendige, kleurvaste kleuren, perfect om buiten te gebruiken.

ONDERHOUD

Trizo is gemakkelijk te onderhouden. Gebruik een oplossing van warm, zuiver water en een pH-neutraal vloeibaar reinigingsmiddel of de Synthetics Super Cleaner (p. 208) om vlekken te verwijderen. Zacht schuren verhelpt kleine krassen zodat Trizo zijn charme behoudt, gebruik hier zeker geen harde schuurmiddelen voor. Het gebruik van een cover kan het materiaal extra bescherming bieden en het aantal benodigde onderhoudsbeurten verminderen. We raden de Synthetics Protector (p. 208) aan voor extra bescherming, dit product vormt een onzichtbaar laagje dat vuil afstoot.



TEAK SUPER CLEANER - D9914 - 500 ml

Cleaner for regular or intensive cleaning.

1. First moisten the furniture with clear water.
2. Shake the Teak Cleaner well before use.
3. Apply Teak Cleaner with a soft cloth and allow to soak for 3 minutes.
4. Brush the furniture clean with the soft scrubbing pad in the direction of the grain.
5. Rinse well with clear water.

Produit pour un nettoyage normal ou intensif.

1. Mouillez d'abord le meuble avec de l'eau.
2. Agitez Teak Cleaner avant l'emploi.
3. Appliquez Teak Cleaner avec un chiffon sur le meuble et laissez agir 3 minutes.
4. Brossez le meuble avec le patin de ponçage doux en suivant le fil du bois.
5. Rincez bien le meuble à l'eau.

Reiniger voor normale of intensieve reiniging.

1. Het meubel eerst vochtig maken met water.
2. Teak Cleaner schudden voor gebruik.
3. Breng de Teak cleaner met een doek op het meubel aan en laat dit 3 minuten intrekken.
4. Borstel het meubel met het zachte schuurpad richting houtnerf schoon.
5. Het meubel goed afspoelen met water.



TEAK SEALER NATURAL - D9959 - 1000 ml

When Teak Sealer is applied every season, a labour-intensive cleaning with Teak Cleaner will not be necessary for many years. A simple cleaning with water and ph-neutral soap will do.

1. Allow new teak to weather for 1 to 2 weeks before applying Teak Sealer.
2. Clean soiled teak with Teak Cleaner or Teak Super Cleaner and leave to dry until the wood is completely dry.
3. Stir the Teak Sealer well and keep mixing throughout the application process.
4. Apply to the teak using a microfiber cloth, synthetic sponge or plants spray in the direction of the grain. Wipe any excess off with a microfiber cloth.
5. Leave to dry for 1 hour and apply a second coat.
6. Wipe over the second coat with a clean cloth.
7. The teak should be dry to the touch in 1 hour and ready for use the next day.

Appliquer Teak Sealer une fois par saison permet de se passer d'un nettoyage intensif avec Teak Cleaner pendant plusieurs années. Nettoyer de temps en temps à l'eau avec un savon au pH neutre entre les traitements suffira.

1. Laissez le teck neuf se patiner une ou deux semaines avant le traitement.
2. Nettoyez soigneusement le teck souillé avec Teak Cleaner ou Teak Super Cleaner et laissez bien sécher.
3. Remuez bien le Teak Sealer et continuez à remuer souvent pendant l'application.
4. Appliquez avec un chiffon en microfibre, une éponge synthétique ou un pulvérisateur plante dans le sens du bois. Essuyez le produit excédentaire avec un chiffon en microfibre.
5. La 1re couche est sèche au bout d'une heure. Appliquez immédiatement une 2e couche.
6. Frottez avec un chiffon propre ne peluchant pas.
7. Le bois est sec hors poussière au bout d'une heure et prêt à l'emploi le lendemain.

Als u elk seizoen Teak Sealer aanbrengt, is een arbeidsintensieve reiniging met Teak Cleaner jarenlang niet meer nodig. Een eenvoudige reiniging met water en een neutrale zeep volstaat.

1. Nieuwe teak eerst 1 tot 2 weken laten verweren vóór behandeling met Teak Sealer.
2. Vervuilde teak grondig reinigen met Teak Cleaner of Teak Super Cleaner en goed laten drogen.
3. Teak Sealer goed roeren, ook tijdens de verwerking.
4. Aanbrengen met een microvezeldoek, een kunstspoon of een plantensproeier in de richting van de nerven, overtollig product met een microvezeldoek wegvegen.
5. 1 uur laten drogen en 2de laag aanbrengen.
6. Opwrijven met schone pluisvrije doek.
7. Na 1 uur stofdroog, volgende dag gebruiksklaar



TEAK PROTECTOR GREY COLOUR - D9912 - 500 ml

Protects the teak against stains and green deposit. Doesn't colour the grey patina

1. New teak: leave your new furniture outside during a few weeks until they get a pale colour.
2. Old, grey teak: clean the teak first with Teak Cleaner. If the cleaned wood feels rough, sand slightly before using the Teak Protector.
3. Make sure that the teak is 100% dry and free of dust.
4. Shake the bottle for at least one minute. Apply with the soft and lint-free cloth and allow to soak in the teak.
5. Allow to dry for 4 hours, then apply a second layer.
6. Let the teak dry for 24 hours before exposing it to moisture.

Protège le teck des taches et de la mousse. Ne colore pas la patine grise.

1. Teck neuf: placez d'abord les meubles quelques semaines dehors afin qu'ils prennent une couleur jaune pâle.
2. Teck vieux et grisé: nettoyez d'abord le bois avec Teak Cleaner. Si la surface du teck est rugueuse, poncez-la légèrement.
3. Assurez-vous que le teck soit 100 % sec et dépoussiéré.
4. Agitez Teak Protector au moins une minute avant d'appliquer. Appliquez une couche avec un chiffon doux ne peluchant pas. Laissez agir.
5. Appliquez une seconde couche au bout de 4 heures.
6. Laissez le teck sécher pendant 24 heures avant de l'exposer aux intempéries.

Beschermt de teak tegen vlekken en mos. Kleurt de grijze patina niet.

1. Nieuw teak: zet de teak meubels eerst enkele weken buiten zodat ze een wat bleekgele kleur krijgen.
2. Oud, donkergrijs teak: maak het teak eerst schoon met Teak Cleaner. Als het teak ruw aanvoelt, schuur het lichtjes op.
3. Zorg dat het teak 100% droog is en stofvrij.
4. Teak Protector voor gebruik minstens één minuut goed schudden. Breng één laag aan met een zachte, pluïsvrije doek. Laat goed intrekken.
5. Breng na 4 uur droogtijd een tweede laag aan.
6. Laat het teak nu 24 uur drogen alvorens het aan de weersomstandigheden bloot te stellen.



POWDERCOATED ALUMINIUM & STAINLESS STEEL CLEANER - D9952 - 500 ml

Cleans powdercoated aluminium and powdercoated stainless steel.

1. Rinse the furniture with clear water to eliminate loose dirt.
2. Spray the Coated aluminium & stainless steel Cleaner on the surface and let it rest.
3. In case of stubborn stains use a brush to remove the dirt from the pores.
4. Rinse with clear water and remove the dirt with a clean, moist cloth.
5. Dry with a microfiber cloth. Don't leave the surface to dry in full sun, this can leave white traces behind.

Nettoie l'aluminium et l'inox laqué par poudrage.

1. Rincez le meuble d'abord afin d'éliminer des saletés.
2. Pulvérisez Coated aluminium & stainless steel Cleaner de bas en haut sur la surface et laissez agir.
3. Si la saleté est incrustée, utilisez une brosse pour éliminer la saleté des pores.
4. Rincez avec de l'eau claire et éliminez la saleté avec un chiffon propre et humide.
5. Séchez avec un chiffon microfibre. Ne laissez pas sécher en plein soleil (peut laisser des traînées blanches).

Reinigt gepoederlakt aluminium en gepoederlakt roestvast staal.

1. Spoel het meubel eerst om los vuil te verwijderen.
2. Vernevel de Coated aluminium & stainless steel Cleaner over het oppervlak en laat inwerken.
3. Gebruik bij hardnekkig vuil een borstel om het vuil uit de poriën te verwijderen.
4. Spoel af met zuiver water en verwijder het vuil met een propere, vochtige doek.
5. Niet laten drogen in volle zon (kan witte sporen achterlaten).

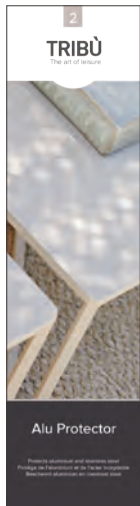

POWDERCOATED ALUMINIUM & STAINLESS STEEL PROTECTOR - D9931

Reduces the adhesion of dirt and fingerprints.

1. Shake well before use.
2. Spray onto a clean microfiber cloth and rub on the surface with circular movements.
3. Use a clean, dry microfiber cloth and spread well.

Réduit sensiblement l'adhérence de la saleté ou des empreintes.

1. Agitez bien avant l'emploi.
2. Pulvérisez sur un chiffon en microfibre et faites pénétrer en frottant légèrement avec des mouvements circulaires.
3. Utilisez un chiffon en microfibre propre et sec et frottez bien.

Vermindert gevoelig de aanhechting van vuil of vingerafdrukken.

1. Goed schudden voor gebruik.
2. Op een schone microvezeldoek spuiten en licht inwrijven met cirkelvormige bewegingen.
3. Gebruik een schone, droge microvezeldoek en wrijf goed uit.



CERAMIC, LAVA STONE & GLASS CLEANER - D9938 - 500 ml

Removes local stains.

1. Shake well before use.
2. Spray the surface with the spray and leave for a while.
3. Rub to dry with a clean microfiber cloth and polish with a dry cloth.

Élimine les taches tenaces locales.

1. Agitez bien le flacon avec l'emploi.
2. Pulvérisez la mousse à la surface et laissez agir quelques instants.
3. Essuyez avec un chiffon propre au microfibre et séchez avec un chiffon sec.

Verijdert plaatselijk hardnekkige vlekken.

1. Bus goed schudden voor gebruik.
2. Het oppervlak inspuiten met de schuimspray en even laten inwerken.
3. Droogwrijven met een propere, microvezel doek en nawrijven met een droge doek.



CERAMIC, LAVA STONE & GLASS PROTECTOR - D9955 - 100 ml

Applies an invisible, dirt repellent coating.

1. Clean the surface with Ceramic, Lava Stone & Glass Cleaner.
2. It is essential that the surface is completely clean, dust free and dry before applying the Ceramic Protector.
3. Moisten a microfiber cloth with the Ceramic Protector and apply a layer to the surface, ensuring full and even coverage by fast circular movements.
4. Allow the newly coated surface to dry for a few minutes and then polish the surface with a clean microfiber cloth.

Offre une protection invisible contre les taches et la saleté.

1. Nettoyez parfaitement la surface avec Ceramic, Lava Stone & Glass Cleaner et rincez à l'eau claire. Il est important que la surface soit complètement propre, sèche et dépoussiérée.
2. Imprégnez un chiffon en microfibre de Ceramic Protector et appliquez une couche uniforme en mouvements circulaires.
3. Continuez à frotter la surface jusqu'à ce que le chiffon soit presque sec.
4. Laissez sécher au minimum 1 minute (idéalement 5 minutes) et lustrez la surface avec un chiffon en microfibre propre.

Brengt een transparante, vuilwerende bescherming aan.

1. Maak het oppervlakte grondig schoon met Ceramic, Lava Stone & Glass Cleaner en spoel na met zuiver water. Het is belangrijk dat het oppervlak volledig schoon, droog en stofvrij is.
2. Doordreng een microvezel doek met Ceramic Protector en breng door middel van circulaire bewegingen een gelijkmatige coating aan.
3. Ga door met het oppervlak in te wrijven totdat de doek bijna droog is.
4. Laat minimum 1 minuut drogen (ideaal 5 minuten) en boen vervolgens het oppervlak met een schone microvezel doek.



SYNTHETICS SUPER CLEANER - D9922 - 500 ml

Cleans stubborn stains from synthetic materials, Canax®, CTR; Elio, Mood, Tosca weave and Batyline®.

1. Rinse the furniture with clear water to eliminate loose dirt.
2. Spray the Synthetics Super Cleaner on the surface and let it soak.
3. In case of stubborn stains use a brush to remove the dirt from the pores.
4. Rinse with clear water and remove the dirt with a clean, moist cloth.
5. Dry with a microfiber cloth. Don't leave the surface to dry in full sun, this can leave white traces behind.

Enlève des taches tenaces sur matériaux synthétiques, les tressages Canax®, CTR, Elio, Mood et Tosca et du Batyline®.

1. Rincez le meuble d'abord avec de l'eau claire afin d'enlever la saleté.
2. Pulvérisez Synthetics Super Cleaner sur la surface et laissez agir.
3. Si la saleté est incrustée, utilisez une brosse pour éliminer la saleté des pores.
4. Rincez et éliminez la saleté avec un chiffon propre, humide.
5. Séchez avec un chiffon en microfibre. Ne laissez pas sécher en plein soleil (peut causer des traînées blanches).

Verwijdert hardnekkige vlekken op kunststof, Canax®, CTR, Elio, Mood en Tosca weving en Batyline®.

1. Spoel het meubel eerst met zuiver water om loszittend vuil te verwijderen.
2. Vernevel de Synthetics Super Cleaner van onder naar boven over het oppervlak en laat inwerken.
3. Gebruik bij hardnekkig vuil een borstel om het vuil uit de poriën te verwijderen.
4. Spoel af en verwijder het vuil met een propere, vochtige doek.
5. Droogwrijven met een microvezeldoek. Niet laten drogen in volle zon (kan witte sporen achterlaten).



SYNTHETICS PROTECTOR - D9921 - 500 ml

Applies an invisible film and protects against the adhesion of dirt. Suitable for synthetic materials, Canax® and Batyline®.

1. First clean your furniture with Synthetics Cleaner.
2. Shake the bottle well during at least one minute.
3. Apply a thin layer with a clean, dry and lint-free cloth.
4. Buff to shine with a soft, clean and dry cloth.

Offre une protection invisible contre les taches. A utiliser sur des matériaux synthétiques, Canax® et du Batyline®.

1. Nettoyez d'abord vos meubles avec Synthetics Cleaner.
2. Agitez Synthetics Protector au moins une minute avant d'appliquer.
3. Appliquez une couche mince avec un chiffon doux et sec.
4. Frottez ensuite avec un chiffon propre et sec jusqu'à ce que la surface devienne brillante.

Brengt een onzichtbare laag aan die beschermt tegen de aanhechting van vuil. Geschikt voor kunststof, Canax® en Tosca weving en Batyline®.

1. Reinig eerst uw meubels met Synthetics Cleaner.
2. Synthetics Protector vóór gebruik minstens één minuut goed schudden
3. Breng een dunne laag aan met een schone, droge doek.
4. Oppoetsen met een droge, schone doek tot er een glans ontstaat.



TEXTILE PROTECTOR - D9924 - 400 ml

Makes fabric and weaves water and stain repellent.

1. Shake well before use.
2. Hold the spray can upright at a distance of approximately 30cm and vaporise in equal layers that slightly overlap each other.
3. Leave to dry.
4. For an optimal protection, after each cleaning, we recommend to use Textile Protector.

Rend des tissus et des tissages hydrofuges et résistants aux taches.

1. Agitez bien le flacon.
2. Pulvérisez en bandes se chevauchant légèrement. Maintenez le flacon droit et pulvérisez à +/- 30 cm de distance.
3. Laissez bien sécher.
4. Pour une protection parfaite, nous vous conseillons d'utiliser Textile Protector après chaque nettoyage.

Maak stoffen en wevingen waterafstotend en vlekwerend.

1. De bus goed schudden
2. De bus rechtop houden en spuiten op +/- 30cm afstand. Spuiten in banden die elkaar licht overlappen.
3. Goed laten drogen.
4. Voor een perfecte bescherming raden we aan na iedere reinigingsbeurt Textile Protector te gebruiken.



GRANITE CLEANER/PROTECTOR - D9961 - 500 ml

Cleans, maintains and protects granite surfaces.

1. Shake before use, then open the spray valve.
2. Spray the surface in an evenly way.
3. Spread and polish with a microfiber cloth until no more streaks or veil is visible.

Nettoie, traite et protège des surfaces en granite.

1. Secouez avant utilisation, puis ouvrir la buse de pulvérisation
2. Pulvérisez bien régulièrement les surfaces.
3. Etalez et polissez avec un chiffon en microfibre, jusqu'à ce que plus aucune strie ou voile ne soit visible.

Reinigt, verzorgt en beschermt oppervlakken in graniet.

1. Schudden voor gebruik, daarna sproeiventiel openen.
2. Het oppervlak gelijkmatig besproeien.
3. Met een microvezeldoek verdelen en napolieren tot er geen strepen of sluier meer zichtbaar zijn.

LIGHTENED CONCRETE CARE SET - D9964

A complete set to take care of tables in lightened concrete.

- 1 Lightened Concrete Conditioner
- 1 Oil, wax & Grease Remover
- 1 sanding disc
- 1 brush
- 1 microfiber cloth

Un set complet pour l'entretien des tables en béton allégé.

- 1 Lightened Concrete Conditioner
- 1 Oil, wax & Grease Remover
- 1 disque de ponçage
- 1 brosse
- 1 chiffon en microfibre

Een complete set voor het onderhoud van tafels in verlicht beton.

- 1 Lightened Concrete Conditioner
- 1 Oil, Wax & Grease Remover
- 1 schuurschijfje
- 1 borstel
- 1 microvezeldoek

LIGHTENED CONCRETE CONDITIONER – D9962 – 500ml

Cleans surfaces in lightened concrete and protects against stains.

1. Wash the surface with clean water first and allow it to dry completely.
2. Shake before use, open the spray valve and spray lightly in an evenly way over the cooled surface.
3. Rub in with a clean, dry microfibre cloth with a circular motion or use a soft brush.
4. After approx. 10 minutes, remove the excess product with a clean, dry microfibre cloth until no more streaks or veil are visible.

Nettoie des surfaces en béton allégé et protège contre des taches.

1. Avant toute chose, nettoyez la surface à l'eau claire, puis laissez sécher complètement.
2. Secouez le flacon avant utilisation. Enclenchez le pulvérisateur et vaporisez uniformément une fine couche de produit.
3. Ensuite, frottez avec un chiffon microfibre sec et propre en effectuant des mouvements circulaires ou utilisez une brosse.
4. Après 10 minutes environ, retirez l'excédent de produit à l'aide d'un chiffon sec et propre jusqu'à ce que plus aucune strie ou voile ne soit visible.

Reinigt oppervlakken in verlicht beton en beschermt tegen vlekken.

1. Vooraf het oppervlak met zuiver water schoonmaken en volledig laten opdrogen.
2. De fles schudden voor gebruik, het sproeiventiel openen en het product lichtjes en gelijkmatig vernevelen over het afgekoelde oppervlak.
3. Vervolgens het product met een zuivere, droge microvezel doek met cirkelvormige bewegingen inwrijven of een borstel gebruiken.
4. Na ca 10min het overtollige product met een zuivere, droge microvezeldoek verwijderen tot er geen strepen of sluier meer zichtbaar zijn.

**OIL, WAX & GREASE REMOVER – D9963 – 250ml**

A creamy paste that removes stains on lightened concrete caused by oil, grease or candle wax.

1. Wash the surface with clean water first to remove any loose dirt and make sure it is completely dry before you apply the product.
2. Apply a layer of paste, approx. 1 mm thick, evenly over the stain using a spatula or brush and leave the paste to soak in. Apply in open air during daytime and dry weather only.
3. After drying for approx. 30-60 minutes, brush off the paste. Repeat this process for stubborn or old stains.
4. Rinse the furniture with clean water and let it dry.
5. For optimal protecting against stains, treat the surface with Tribù Lightened Concrete Conditioner.

Une pâte crémeuse qui enlève des taches causées par l'huile, la graisse ou la cire de bougie sur le béton allégé.

1. Avant toute chose, nettoyez le meuble à l'eau claire afin d'enlever toute trace de saleté. Assurez-vous qu'il est complètement sec avant d'appliquer le produit.
2. À l'aide d'une spatule ou d'une brosse, répartissez une couche uniforme d'environ 1 mm, et laissez agir. Appliquer en plein air pendant la journée et par temps sec uniquement.
3. Après 30-60 minutes environ, retirez la pâte avec une brosse. En cas de tache tenace ou ancienne, répétez l'opération.
4. Rincez à l'eau claire et laissez sécher.
5. Pour une protection optimale contre les taches, traitez le béton allégé avec du Tribù Lightened Concrete Conditioner.

Een smeijge pasta die vlekken op verlicht beton, veroorzaakt door olie, vet of kaarsvet verwijderd.

1. Spoel het meubel eerst met zuiver water om loszittend vuil te verwijderen en zorg dat het volledig droog is vooraleer je het product gebruikt.
2. Breng de pasta gelijkmatig met een spatel of borstel ca 1mm dik aan over de vlek en laat deze inwerken. Alleen overdag in open lucht en bij droog weer aanbrengen.
3. Na een droogtijd van ca 30-60min kan je de pasta afborstelen. Bij intense of oude vlekken moet dit proces eventueel meerdere keren herhaald worden.
4. Spoel het oppervlak met zuiver water en laat drogen.
5. Voor een optimale bescherming tegen vlekken, behandel het verlicht beton met Tribù Lightened Concrete Conditioner.



INOX SUPER CLEANER (CB & EP) - D9918 - 250 ml

Intensive cleaner for in-depth cleaning.

1. Rinse the furniture with clear water and let it dry.
2. Shake the bottle well.
3. Apply the cleaner undiluted by dabbing by means of a damp sponge or pad. Apply in the rolling direction of the surface to be treated. Leave to act.
4. Remove the residue carefully with a damp cloth (be careful, loose dirt or oxide may cause minor scratches).
5. Rinse abundantly with clear water.

Nettoyant intensif pour des saletés tenaces.

1. Rincez le meuble et laissez sécher.
2. Agitez bien le flacon.
3. Appliquez le produit non dilué avec une éponge humide dans le sens du laminage du matériau ou dans le sens de la surface brossée ou meulée. Laissez agir.
4. Éliminer précautionneusement les résidus à l'eau ou avec un chiffon humide (attention : la saleté et/ou les oxydes détachés pourraient provoquer de légères rayures).
5. Rincez abondamment à l'eau claire.

Intensieve reiniger voor hardnekkige verontreiniging.

1. Spoel het meubel met zuiver water en laat drogen.
 2. De fles goed schudden.
 3. Breng de reiniger onverdund aan met een vochtige spons al deppend in de walsrichting van het materiaal. Even laten inweken.
 4. Verwijder residuen zorgvuldig met water of een vochtige doek (let op: het loskomend vuil en/of oxiden kunnen eventueel lichte krassen veroorzaken).
 5. Overvloedig spoelen met zuiver water.
-

PRODUCTS

PRODUITS - PRODUCTEN

TRAVERTINE CONDITIONER - D9967

1. Cleaning: The surface must be clean, dry, and free of layers. For outdoor use, ensure that the stone does not contain harmful salts (nitrates, sulfates, chloride), as these can reduce the absorption capacity of the impregnation.
2. Shake before use.
3. To check the usage, color deepening, and effectiveness, it is recommended to test on a small surface.
4. Processing temperature: 10°C to 25°C; avoid direct sun exposure and moisture until the product is fully effective.
5. Depending on the porosity of the stone, apply the product undiluted, wet on wet, evenly on the stone one or more times with a brush, mop, spray device, or lint-free cloth.
6. Always treat the entire surface.
7. Approximately 20 minutes after application, as the surface begins to dry, remove the excess product with a cloth. For polished surfaces, polish with a lambswool.
8. Full effectiveness is reached after approximately 24 hours.
9. Non-compliance with processing guidelines may lead to irreversible damage.

1. Nettoyage : La surface devrait être propre, sèche et exempte de couches. Pour une utilisation en extérieur, assurez-vous que la pierre ne contient pas de sels nocifs (nitrates, sulfates, chlorure), car ils peuvent réduire la capacité d'absorption de l'imprégnation.
2. Agiter avant l'usage.
3. Pour vérifier l'usage, la profondeur de la couleur et l'efficacité, il est recommandé de prendre un échantillon.
4. Température de traitement: 10°C à 25° degrés; éviter l'exposition directe au soleil et l'humidité jusqu'à ce que le produit soit entièrement efficace.
5. En fonction de la porosité de la pierre, appliquez le produit non dilué, humide sur humide, uniformément sur la pierre une ou plusieurs fois avec un pinceau, une serpillière, un pulvérisateur ou un chiffon non pelucheux.
6. Traiter toujours toute la surface.
7. Environ 20 minutes après l'application, lorsque la surface commence à sécher, enlever l'excédent de produit avec un chiffon. Pour les surfaces polies, polir avec une laine d'agneau.
8. L'efficacité totale est atteinte après environ 24 heures.
9. Le non-respect des directives de traitement peut causer des dégâts irréversibles.

1. Reiniging: het oppervlak moet zuiver, droog en vrij zijn van andere producten. Bij buitengebruik moet erop gelet worden dat de steen geen schadelijke zouten bevat (nitraten, sulfaten, chloride), aangezien deze het opnamevermogen van de impregnering verminderen.
2. Schudden voor gebruik.
3. Om het gebruik, de kleurverdieping en de werkzaamheid te controleren, wordt aangeraden een proefstuk te nemen.
4. Verwerkingstemperatuur: 10°C tot 25°C; directe zoninwerking en vochtinwerking vermijden totdat het product volledig werkzaam is.
5. Afhankelijk van de poreusiteit van de steen één- of meerdere malen het product onverdund, nat op nat, gelijkmatig op de steen aanbrengen met een penseel, mop, spuittoestel of pluisvrije doek.
6. Behandel steeds het volledige oppervlak.
7. Ongeveer 20 minuten na het aanbrengen, als het oppervlak begint te drogen, het overtollige product met een doek verwijderen. Bij gepolijste oppervlakken met een lamsvel napolijsten.
8. De volle werkzaamheid wordt bereikt na ongeveer 24 uur.
9. Het niet naleven van de verwerkingsrichtlijnen kan leiden tot onherstelbare schade.

ELMINA[®]

môj životný štýl

ELMINA Bratislava
OC Lightpark
Račianska 90, Bratislava
tel.: 02/634 522 59
elmina@elmina.sk
www.elmina.sk

Ceny vr. DPH